

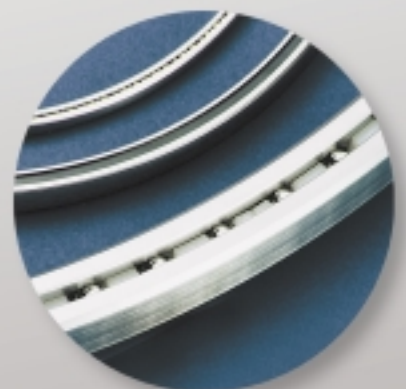
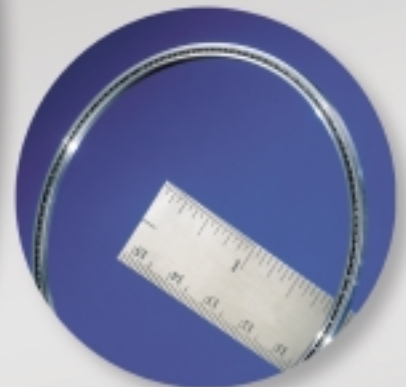
Catalog 300

# Reali-Slim®

Ball & Roller Bearings



TURNING IDEAS INTO ENGINEERED SOLUTIONS



An engineering manual and product selection guide  
[www.reali-slim.com](http://www.reali-slim.com)

# Reali-Slim®—The Industry Standard in Thin-Section Bearings



When your design calls for thin-section, call on Kaydon. We're the largest manufacturer of thin-section bearings in the world. Reali-Slim® thin-section bearings were designed to save space, lower the overall weight of your designs, dramatically reduce friction, and provide excellent running accuracy. With Reali-Slim® you can downsize your design and cut manufacturing costs, without sacrificing bearing performance or life.

In addition to the complete stock of popular cross-sections and bore sizes (up to 40") you'll see in this catalog, our thin-section bearings are also available for a wide variety of special applications.

- Need bearings with corrosion resistance comparable to 440 stainless steel, but with a harder surface finish? **Our Endurakote® plating is ideal. See Section 2.**
- Need bearings for extreme environments? **See our P, X, or Y series stainless steel and hybrid bearings. See Section 6.**
- Did you know that Kaydon supplies metric Reali-Slim® bearings? **See Section 6.**
- Does your design call for a housed bearing with or without gearing? **Specify the TG Series. See Section 6.**
- Got special load, speed, accuracy, or mounting requirements? **Reali-Slim® higher level assemblies may be the solution.**



In this catalog, you'll find a thin-section bearing for virtually every purpose. What's more, with Reali-Slim® bearings you also benefit from Kaydon's expert design and applications engineering assistance, dependable customer support, and off-the-shelf delivery from distributors nationwide.

Specify Reali-Slim® thin-section bearings for compact, lightweight designs of the future.



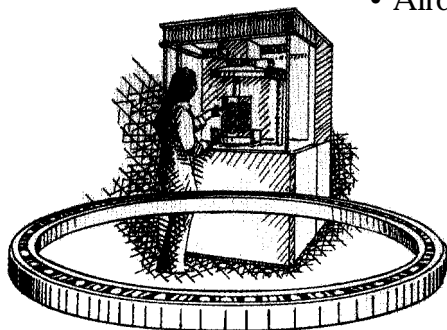
# Table of Contents

	<b>Page Number</b>
<b>Section 1—An Introduction to Reali-Slim® Thin-Section Bearings</b> .....	<b>4</b>
• Product Line Overview	
• Specification Control	
• Examples of Design Efficiency	
• Bearing Load Scenarios	
• General Information and Availability Chart	
• General Specifications for Standard Bearings	
• Part Numbering System Explanation	
<b>Section 2—Selection Tables for Standard Reali-Slim® Bearings</b> .....	<b>14</b>
• Selection Tables, Open Bearings, 52100: Types A, C, X	
• Selection Tables, Sealed Bearings, 52100: Types C, X	
• Selection Tables, Open Bearings, 440C: Types A, C, X	
• Precision Classes Available - Non-plated Bearings	
• Endurakote® Plated Bearings - Description and Working Data	
• Comparative Tolerances - Plated Bearings	
<b>Section 3—Applications Engineering</b> .....	<b>46</b>
• Selection Recommendations	
• Capacity, Life, and Load Analysis	
• Mounting Recommendations	
<b>Section 4—Performance Considerations and Commercial Options Available</b> .....	<b>62</b>
• Separator Types	
• Number of Balls in Standard Bearings	
• Limiting Speeds	
• Torque	
• Axis Deviations	
• Deflection Curves	
<b>Section 5—Installation and Maintenance</b> .....	<b>80</b>
• Inspection and Installation Procedures	
• Lubrication and Maintenance	
<b>Section 6—Other Products</b> .....	<b>85</b>
• Hybrid Series Bearings for Harsh Environments	
• Metric Series Bearings	
• Ultra-Slim Series Bearings	
• KT Series Tapered Roller Bearings	
• TG Series Bearing Assemblies	
<b>Section 7—Appendix and Sales Information</b> .....	<b>104</b>
• Terms and Definitions	
• Warranty Information	
• Application Data Form	
• Engineering Design Aids and Technical Literature	

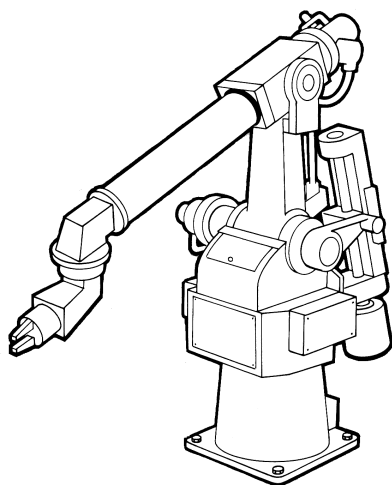
# **Section 1— An Introduction to Reali-Slim® Thin-Section Bearings**

- **Product Line Overview.....pg.6**
- **Examples of Design Efficiency .....pg.7**
- **Bearing Load Scenarios .....pgs.8-9**
- **Product Availability Chart.....pg.10**
- **Specifications for Standard Bearings .....pg.11**
- **Part Numbering System Explanation .....pgs.12-13**

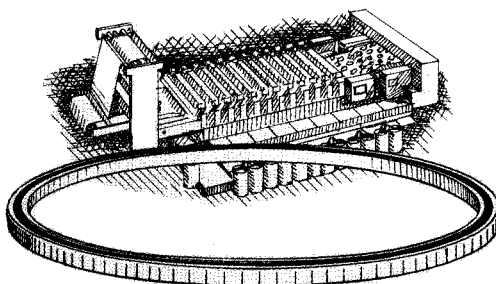
# Reali-Slim®...For Compact, Lightweight Designs of the Future.



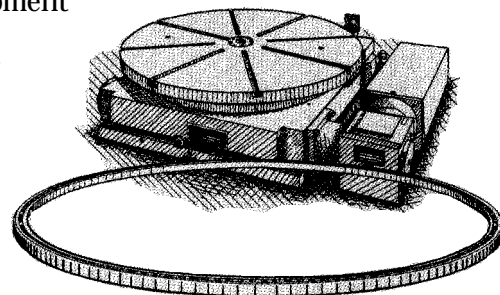
**Semiconductor  
Fabrication Equipment**



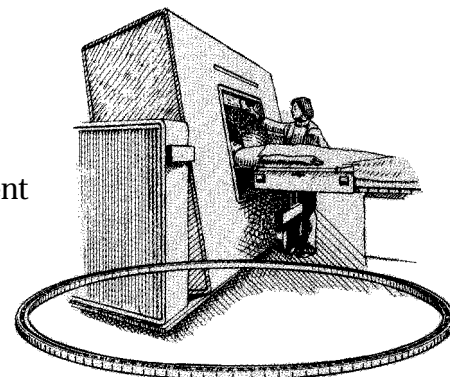
**Industrial Robots**



**Textile Printer**



**Rotary Table**



**CAT Scanner**

- Aircraft, aerospace and astronomy instrumentation
  - Fixturing and workholding equipment
  - Food processing equipment
  - Glassworking equipment
  - Index and rotary tables
  - Packaging equipment
    - Machine tools
    - Medical devices
- Optical scanning equipment
  - Tire making equipment
- Radar, satellite and communications equipment
  - Robotics
  - Textile machinery
  - Tube and pipe cutting machines
- Semiconductor manufacturing equipment
  - Sorting equipment

Kaydon Reali-Slim® bearings were designed to fill the need for a fully hardened, thin-section, anti-friction bearing—a need resulting from the modern design concepts of simplicity, miniaturization, weight reduction, and compactness being applied to a wide variety of rotating devices.

Before the introduction of Reali-Slim® bearings, designers were forced to use bushings or select bearings from the lightest bear-

ings then commercially available, the standard “Light”, “Extra-Light”, and “Extremely Light” series—many of which often had undesirable cross sections, and excess weight.

Reali-Slim® bearings overcome the problems of excess weight and size in bearings, shafts, and housings.

# Product Line Overview

The Reali-Slim® product line consists of a family of seven open and five sealed series of thin section bearings ranging in bore diameters from 1.000 inch to 40.000 inch. Series range from .187 x .187 inch to 1.000 x 1.000 inch in cross section. Open bearings are available from stock in three configurations (Type A, C & X). Stock sealed bearings are available in Types C & X only.

When required, we can provide internal fit up, lubricants, separators and other features to meet the most demanding application requirements. To obtain corrosion resistance consider using Kaydon's stainless steel Reali-Slim® or Endura-Slim® series of bearings. This series provides corrosion protection equal to or better than a full 440C stainless steel bearing.

Additional product line variants include Harsh Environment bearings, Metric Reali-Slim® bearings, BB metric ball bearings, Ultra-Slim® bearings, TG series bearing assemblies, and KT thin-section taper bearings. See Section 6.

Within these families, you can generally choose between open bearings (for applications where bearings will not be exposed to damaging particulates) and sealed bearings (for applications where bearings need to be kept clean and well lubricated).

To support various load scenarios, Reali-Slim® bearings are available in three basic types: radial contact (Type C), angular contact (Type A), and four-point contact (Type X)—see

pages 8 and 9 for explanations on each type—and in a variety of sizes, or series (e.g., KA, KB, KC, etc.).

Reali-Slim® bearings are available with various separator options to space the rolling elements uniformly and prevent contact between them. Separator types available include: continuous ring “snap-over pocket”, continuous ring circular pocket, formed wire, toroid, PTFE spacers, and spacer ball separators. See pages 63 through 67 for complete details.

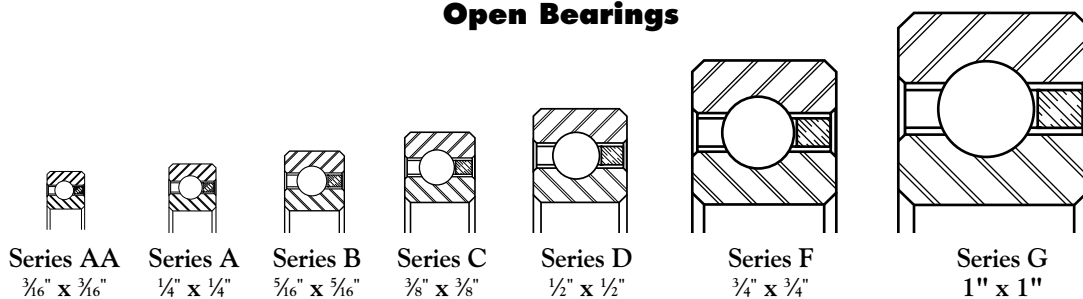
## SPECIFICATION CONTROL

In today's world, product traceability and change control are extremely important. To satisfy these requirements, requesting a “specification control drawing” for a Reali-Slim® bearing is a valuable option to consider.

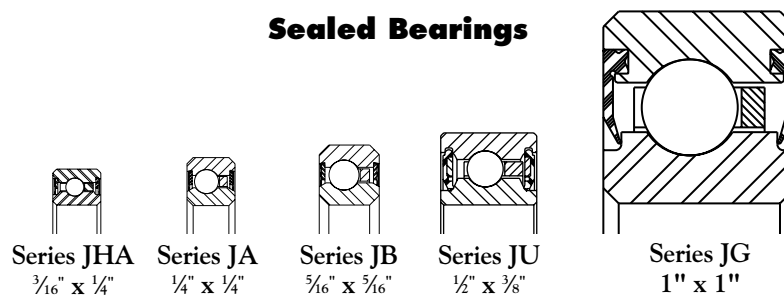
A specification control drawing provides the user a concise and complete accounting of the important bearing features and parameters for a specific application. A specification control drawing request will generate a unique part number for the standard Reali-Slim® bearing and commercially available options required. This provides the customer quick and easy identification of product in the field as well as a concise receiving and inspection document for the factory. A specification control drawing assigned to a Reali-Slim® bearing becomes proprietary to the user for his particular application.

## The Product Line At a Glance

### Open Bearings



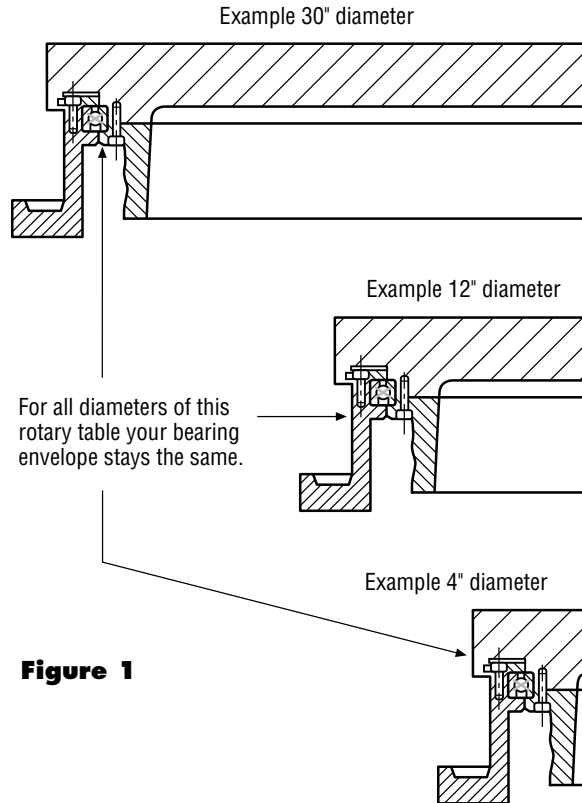
### Sealed Bearings



# Design Efficiency

## An Example of How Reali-Slim® Bearings Improve Design Efficiency

In Reali-Slim® bearings, each series is based on a single cross section which remains constant as the bore diameter is increased. This is in sharp contrast to standard bearings in which the cross section increases as the bore diameter increases. The constant cross section of a Reali-Slim® bearing is of particular value when designing a product which will be manufactured in various sizes based on shaft diameter and power requirements (Figure 1). By using the same series of Reali-Slim® bearings throughout a product line, the designer can standardize on common components. For all diameters of this rotary table your bearing envelope stays the same.



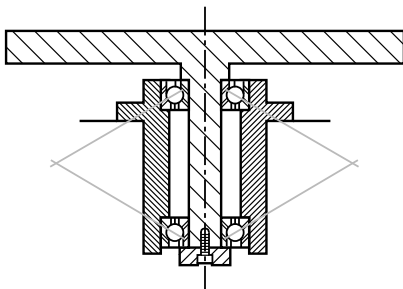
**Figure 1**

## An Example of How Reali-Slim® Bearings Make a More Compact Design

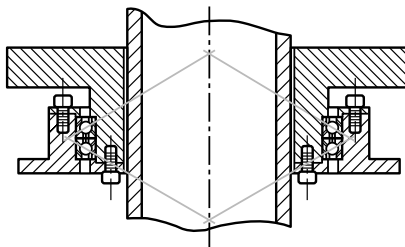
Additional advantages in application design made possible by Reali-Slim® bearings can be seen by referring to Figures 2, 3 and 4. A large bore, small cross section Reali-Slim® bearing permits the use of a large diameter hollow shaft (Figure 3) in place of a smaller diameter solid shaft (Figure 2), king-post design. Components such as air and hydraulic lines or electrical wiring and slip rings can then be accommodated within the hollow shaft, resulting in a neater, more efficient design.

In many applications, a single four-point contact Reali-Slim® bearing (Figure 4) can replace two bearings (Figures 2 and 3) compacting the design and simplifying the bearing mounting. Besides the obvious cost savings of eliminating one bearing, this arrangement also contributes further savings in weight and space. The use of Reali-Slim® bearings also provides a stiffer structure by using large diameter hollow tubes to replace solid shafts and by supporting the rotating structure (table) at the periphery.

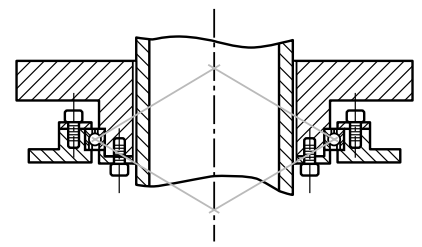
**Figure 2**



**Figure 3**



**Figure 4**

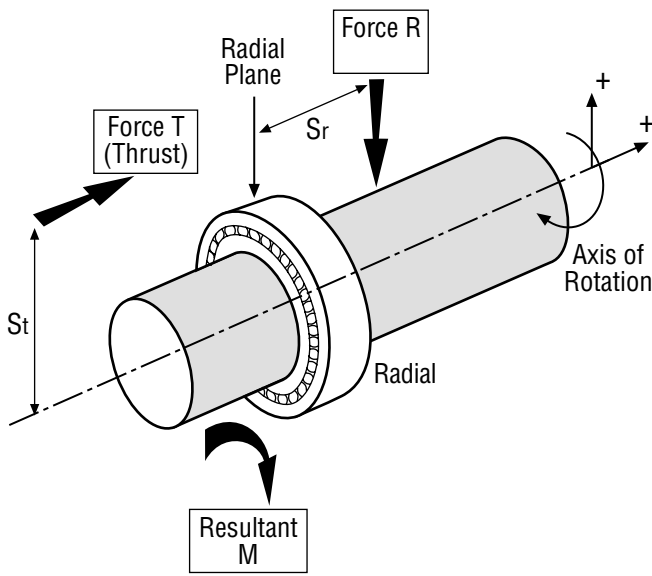


# How Reali-Slim® Bearing Types Support All Load Scenarios

## A Word About Radial and Axial (Thrust) Loads

Bearings support a shaft or housing to permit their free motion about an axis of rotation. Load can be applied to bearings in either of two basic directions (Figure 5). Radial loads act at right angles to the shaft (bearing's axis of rotation). Axial (thrust) acts parallel to the axis of rotation. When these loads are offset from either the bearing axis (distance  $S_t$ ) or radial plane (distance  $S_r$ ), a resulting moment load ( $M$ ) will be created. Kaydon Reali-Slim® bearings are available in a variety of types to handle radial loads, axial loads and moment loads.

**Figure 5**



The resultant moment load ( $M$ ) equation:  
 $M = (\pm T) (S_t) + (\pm R) (S_r)$

## Types of Reali-Slim® Bearings

Reali-Slim® bearings are available in three basic configurations: radial (Type C), angular contact (Type A), and four-point contact (Type X).

Reali-Slim® Bearing Types
A = angular
C = radial
X = four-point

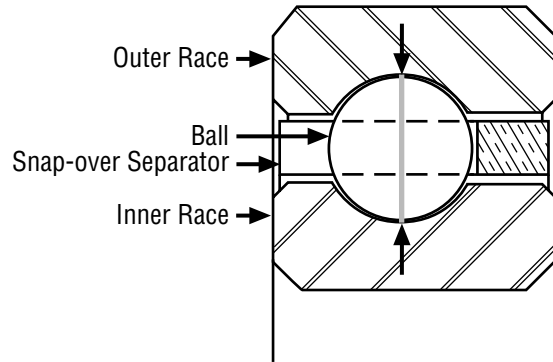
By using these three types, the designer has a wider choice of mounting arrangements to meet load, stiffness and accuracy requirements in the most efficient manner.

## Radial Contact Bearing (Type C)

The Type C Radial Contact Bearing (Figure 6) is a single row radial ball bearing of conventional design. It is a Conrad-type assembly, which means that it is assembled by eccentric displacement of the inner race within the outer race which permits insertion of about half of a full complement of balls.

## Reali-Slim® TYPE C

**Figure 6**



Although the Type C bearing is designed primarily for radial load application, it can be configured to accept some axial (thrust) load in either direction. But, if thrust is a concern, a set of angular contact bearings should be considered for the specific application.



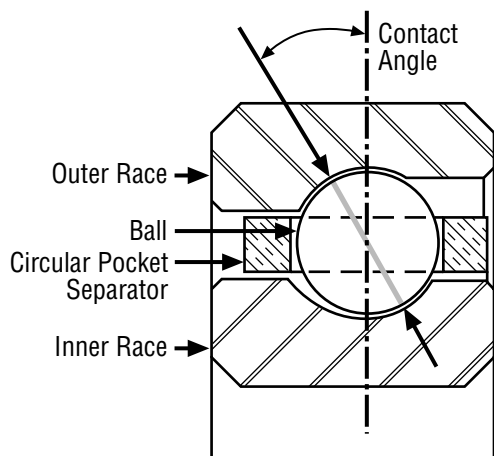
### Angular Contact Bearing (Type A)

The Type A Bearing is also a conventional design. It features a circular pocket separator and a thirty degree contact angle (see Figure 7) along with approximately 67% of a full complement of balls.

The chief benefit of the Type A bearing is that it provides greater thrust capacity than a Type C or Type X bearing. Because of its counterbored outer race, Type A bearings have unidirectional thrust capacity. Thus, this bearing should be mounted opposed to another bearing to establish and maintain the contact angle, and to support reversing thrust loads.

### Reali-Slim® TYPE A

**Figure 7**



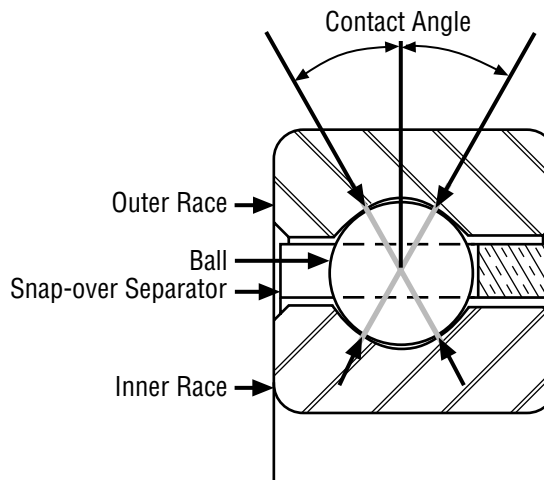
### Four-Point Contact Bearing (Type X)

Standard bearing lines are most often designed to handle either radial or axial load conditions. The unique feature about the Kaydon Reali-Slim® Type X four-point contact bearing line is that the gothic arch geometry of the inner and outer races enables a single bearing to carry three types of loading (radial, axial and moment) simultaneously. This makes it the bearing of choice for many applications since a single four-point contact bearing can often replace two bearings, providing a simplified design.

Type X bearings may also be furnished with an internal diametral preload for those applications requiring greater stiffness or zero free play. This is accomplished by using balls that are larger than the space provided in the raceways. The balls and raceways, therefore, have some elastic deformation in the absence of an external load.

### Reali-Slim® TYPE X

**Figure 8**



**Warning:** Type X bearings are designed to be used singularly. Use of two Type X bearings on a common shaft could result in objectionable friction torque.

# General Information and Availability Chart

**Standard Real-Slim® Bearings**—are those listed in the Series Data Tables. They are manufactured to Kaydon Precision Class 1 and the specifications on page 11.

**Stock Real-Slim® Bearings**—are indicated by dots (•) in the Series Data Tables (pages 15-37) and are also shown below. New sizes are added to stock periodically.

## Options

**Real-Slim® Bearings**—can be optimized for your special application. Standard commercial options include: changes in diametral clearance, preloading, lubricants, packaging, etching of high points, tagging bearings with actual dimensions as requested, separators, duplexing, data sheets, acceptance testing, etc.

**Real-Slim® Bearings**—with non-standard materials, sizes, toler-

ances, specifications, and features are available. We will be pleased to quote on your requirements.

**Order Real-Slim® Bearings**—by bearing numbers shown in Series Data Tables.

**Assistance**—in bearing selection and applications will be furnished by our regional sales managers or the Kaydon Engineering Department upon request. Kaydon welcomes the opportunity to solve your bearing problems.

**Changes**—Kaydon reserves the right to change specifications and other information included in this catalog without notice.

**Errors**—All information, data, and dimension tables in this catalog have been carefully compiled and thoroughly checked. However, no responsibility for possible errors or omissions can be assumed.

**This table applies to 52100 standard bearings. For stainless steel, please see pages 35-37.**

Type Bore	Bore Diameter In Inches																																			
	Series	1	1½	1¾	2	2½	3	3½	4	4¼	4½	4¾	5	5½	6	6½	7	7½	8	9	10	11	12	14	16	18	20	21	22	25	30	35	40			
KA Series	A	•	•	•																																
¾" Radial Section	C	•	•	•																																
	X	•	•	•																																
JA Series	A																																			
¼" Radial Section	C				•	•	•	•	•	•	•	•	•	X																						
	X				•	•	•	•	•	•	•	•	•	X			X																			
KA Series	A				•	•	•	•	•	•	•	•	•	•	•	•	•	•	•	•	•	X														
¼" Radial Section	C				•	•	•	•	•	•	•	•	•	•	•	•	•	•	•	•	•	•	•	•	•	•	•	•	•	•	•	•	•	•	•	
	X				•	•	•	•	•	•	•	•	•	•	•	•	•	•	•	•	•	•	•	•	•	•	•	•	•	•	•	•	•	•	•	
JB Series	A																																			
⅝" Radial Section	C				•	•	•	•	•	•																										
	X				•	•	•	•	•	•																										
KB Series	A				•	•	•	•	•	X	X		X	X	X	X				•																
⅝" Radial Section	C				•	•	•	•	•	•	•	•	•	X	•	•			•	X																
	X				•	•	•	•	•	•	•	•	•	•	•	•			•	•						X										
KC Series	A								•	X	•	X	•	X	•		•	X	X	X		X														
⅝" Radial Section	C								•	•	•	•	•	•	•	•	•	•	•	•	X	•	X	X												
	X								•	•	•	•	•	•	•	•	•	•	•	•	•	•	•	•	•	X										
JU Series	A																																			
⅝" Radial Section	C								•		•	X	•	•	•	•	•	•	•	•	•	•	•	•	X											
	X								•		•	X	•	•	•	•	•	•	•	•	•	•	•	•	X											
KD Series	A								•	•	•	•	•	•	•	•	•	•	X	•	•	•	X	X	X	X	X	X	X							
½" Radial Section	C								•	•	•	•	•	•	•	•	•	•	X	•	•	•	•	•	•	•	X	X								
	X								•	•	•	X	•	•	•	•	•	X	•	•	•	•	•	•	•	•	X	•	X	•	X	X				
KF Series	A																																			
¾" Radial Section	C																																			
	X																																			
KG Series	A																																			
1" Radial Section	C																																			
	X																																			

• Available from stock. x Limited Availability – contact Kaydon for lead time.

# Specifications for Standard Reali-Slim® Bearings

ITEM	DESCRIPTION	REFERENCE SPECIFICATION
<b>MATERIAL ANALYSIS</b>		
<b>RACES &amp; BALLS</b>	AISI 52100 Type Steel Vacuum Degassed 440C Stainless Steel	ASTM A-295, AMS-STD-66 ASTM A-756
<b>SEPARATORS C, X BEARINGS</b>	P Type—Brass or Non-metallic composite L Type—Nylon, Fiberglass Reinforced	ASTM B-36 or B-134
<b>A BEARINGS</b>	R Type—Brass or Non-metallic composite G Type—Nylon, Fiberglass Reinforced	ASTM B-36 or B-134
<b>SEALS</b>	Buna N Rubber, 70 Durometer, Steel Reinforced	MIL-R 6855
<b>HEAT TREATMENT</b>		
<b>RACES</b>	Through hardened and dimensionally stabilized for use from -65°F to +250°F (-54°C to +121°C)	SAE-AMS-H-6875
<b>BALLS</b>	52100—Hardened to Rc 62-66, 440C—to Rc 58-65	
<b>PRECISION</b>		
<b>RACE DIMENSIONS</b>	KAYDON Precision Class 1	ABMA ABEC-1F or better
<b>RACE RUNOUTS</b>	KAYDON Precision Class 1	ABMA ABEC-1F or better
<b>BALLS</b>	Grade 24	ANSI/ABMA/ISO 3290
<b>DIAMETRAL CLEARANCE AND CONTACT ANGLE</b>		
<b>TYPE C BEARING</b>	Sufficient diametral clearance to provide small amount of running clearance after installation with recommended fits Gothic Arch Form for two 30° contact angles under light radial gaging load. Sufficient diametral clearance to provide clearance after installation with recommended fits Diametral clearance for 30° contact angle in single unmounted bearing under light axial gaging load. Wide range of preload or running clearance for matched sets	ABMA Standard 26.2
<b>TYPE X BEARING</b>		
<b>TYPE A BEARING</b>		
<b>SEPARATOR DESIGN</b>		
<b>P &amp; L TYPES C, X BEARINGS</b>	Circular Ring, Snapped Over Balls for Retention	
<b>R &amp; G TYPES A BEARINGS</b>	Circular Ring, Circular Pockets, Self Retained	
<b>QUALITY CONTROL</b>	Kaydon Quality Control procedures have been approved by major aerospace industries and agencies of the U.S. Government	ISO 9001, MIL-I-45208
<b>IDENTIFICATION</b>	Marked on Bearing O.D.: CAGE Code, "KAYDON"®, Part Number and Date Code	MIL-STD-130
<b>CLEANING</b>	Multiple cycle immersion and agitation in solvents and/or aqueous cleaners	
<b>PRESERVATIVE</b>	Preservative Oil	
<b>PACKAGING</b>	Heat Sealed in Plastic Bag & Boxed	MIL-DTL-197, Level C

NOTE—Also available: Quality Control per MIL-Q-9858, Packaging and Lubrication options, and "White Room" Facilities.

# Identification of REALI-SLIM® Bearings

Real-Slim® bearings are marked for complete identification with an (8) or (9) digit part number. Positions 1-8 identify

materials, size, type, and precision. Position 9 (optional) identifies non-standard internal fit.

## Part Number Code Example

Position	1	2	3	4	5	6	7	8	9
Nomenclature	Material	Series	Size			Type	Separator	Precision	Internal Fit
Typical Part No.	K	G	1	2	0	X	P	0	L

### Position 1 - Material

Races/Balls		Seals, Shields	
A	VD 52100 Steel	with	One seal—PTFE
B	VD 52100 Steel	with	Two seals—PTFE
D	VD 52100 Steel	with	One shield
E	VD 52100 Steel	with	Two shields
F	VD 52100 Steel	with	One seal—Buna N rubber Lami-Seal®
G	VD 52100 Steel	with	Two seals—Buna N rubber Lami-Seal®
H	VD 52100 Steel	with	One seal—Buna N rubber
J	VD 52100 Steel	with	Two seals—Buna N rubber
K	VD 52100 Steel	with	No seals or shields
L	VD 52100 Steel	with	Two seals and Endurakote® plating
M	M-50 Steel	with	No seals or shields
N	VD 52100 Steel	with	No seals and Endurakote® plating
P	17-4PH Steel	with	Ceramic Balls (see page 87)
Q	52100 Steel	with	No shields or seals (see page 70)
S	440C Stainless Steel	with	No seals or shields
T	440C Stainless Steel	with	One seal—PTFE
U	440C Stainless Steel	with	Two seals—PTFE
V	440C Stainless Steel	with	Two shields
W	440C Stainless Steel	with	Two seals—Buna N rubber
X	52100 Steel	with	Ceramic Balls
Y	440C Stainless Steel	with	Ceramic Balls (see pages 35-37 & 86-87)
Z	Other		

### Position 2 - Series Cross Section

	Radial Thickness		Width		
Standard Cross-Sections	A	*.187	x	.187	
	or	.250	x	.250	
	B	.312	x	.312	
	C	.375	x	.375	
	D	.500	x	.500	
	E	.625	x	.625	
	F	.750	x	.750	
	G	1.000	x	1.000	
	Extended Width	H	*.187	x	.250
		or	.250	x	.312
I		.312	x	.375	
J		.375	x	.437	
K		.500	x	.578	
L		.625	x	.727	
M		.750	x	.875	
N		1.000	x	1.187	
Extra-Extended Width		S	*.187	x	.312
		or	.250	x	.375
	T	.312	x	.437	
	U	.375	x	.500	
	V	.500	x	.656	
	W	.625	x	.828	
	X	.750	x	1.000	
	Y	1.000	x	1.375	

\*Smaller section applies when position 3 is alphabetic—see following explanations of positions 3, 4, and 5.

**Position 3, 4 and 5—Size (Bearing Bore)**

## Numeric Characters

Nominal bearing bore in inches multiplied by ten

## Alphabetic Characters

“A” In Position 3 in combination with “A” in Position 2 denotes .187 x .187 Series

“A” In Position 3 in combination with “H” in Position 2 denotes .187 x .250 Series

“A” In Position 3 in combination with “S” in Position 2 denotes .187 x .312 Series

## Examples

040 = 4.0" Bore

120 = 12.0" Bore

400 = 40.0" Bore

“10” following “AA” in Positions 2 & 3 =  
.187 x .187 Series with 1.0" Bore

“15” following “HA” in Positions 2 & 3 =  
.187 x .250 Series with 1.5" Bore

**Position 6—Bearing Type (see pages 47-51)**

- A Angular contact single bearing (not ground for universal duplexing)
- B Angular contact pair—duplexed back to back
- C Radial contact
- F Angular contact pair—duplexed face to face
- T Angular contact pair—duplexed tandem
- U Angular contact single bearing—ground for universal duplexing
- X Four-point contact
- Z Other

**Position 7—Separator (see pages 63-67)**

- C Non-metallic composite, segmental, “snap-over” type
- D Phenolic laminate, one-piece ring “snap-over” type
- E Brass, segmental “snap-over” type
- F Full complement bearing—no separator
- G Nylon one-piece ring, circular pocket
- H Phenolic laminate, one-piece ring with circular pockets
- J Nylon strip separator, circular pockets
- K Phenolic laminate, riveted two-piece ring
- L Nylon, one-piece ring “snap-over” type
- M Formed wire, strip or segmental, “snap-over” type, ball in every pocket
- N Nylon, “snap-over” type
- P Standard formed ring “snap-over” type (material—brass or non-metallic composite)
- Q PEEK, one-piece ring, circular pocket

- R Standard formed ring, circular pocket (material—brass or non-metallic composite)
- S Helical coil springs
- T Stainless steel, formed ring “snap-over” type
- U Stainless steel, formed ring circular pockets
- V Brass, formed ring, “snap-over” type
- W Formed wire, strip or segmental, “snap-over” type
- X PEEK, one-piece, “snap-over” pocket
- Y Brass, formed ring, circular pockets
- Z Other (toroids, slugs, spacer balls or others available)

**Position 8—Precision (see pages 38-42)**

(ABEC Specifications are per ABMA Standard 26.2)

- 0 Kaydon Precision Class 1 per ABEC 1F
- 1 Kaydon Precision Class 1 with Class 4 Runouts
- 2 Kaydon Precision Class 1 with Class 6 Runouts
- 3 Kaydon Precision Class 3 per ABEC 3F
- 4 Kaydon Precision Class 4 per ABEC 5F
- 6 Kaydon Precision Class 6 per ABEC 7F
- 8 Other

**Position 9—Bearing Internal Fit**

- A .0000 to .0005 Clearance
- B .0000 to .0010 Clearance
- C .0005 to .0010 Clearance
- D .0005 to .0015 Clearance
- E .0010 to .0020 Clearance
- F .0015 to .0025 Clearance
- G .0020 to .0030 Clearance
- H .0030 to .0040 Clearance
- I .0040 to .0050 Clearance
- J .0050 to .0060 Clearance
- K .0000 to .0005 Preload
- L .0000 to .0010 Preload
- M .0005 to .0010 Preload
- N .0005 to .0015 Preload
- P .0010 to .0020 Preload
- Q .0010 to .0015 Preload
- R .0015 to .0025 Preload
- S .0020 to .0030 Preload
- Z Other clearance or preload not specified above

- Type X or C = Diametral Preload or Clearance
- Duplexed Type A = Axial Preload or Clearance

**Note:** Above internal bearing fits apply to unmounted bearings only. Mounting fits can greatly affect final internal bearing fit.

## **Section 2 — Selection Tables for Standard Reali-Slim® Bearings**

- **Open Bearings - 52100, Selection Tables Types A, C, X .....pgs.15-26**
- **Sealed Bearings - 52100, Selection Tables Types C, X.....pgs.27-34**
- **Open Bearings - 440C, Selection Tables Types A, C, X.....pgs.35-37**
- **Precision Classes Non-Plated Bearings ...pgs.38-42**
- **Endurakote® Plated Bearings .....pgs.43-44**
- **Comparative Tolerances - Plated Bearings .....pg.45**

# Open Bearing Selections

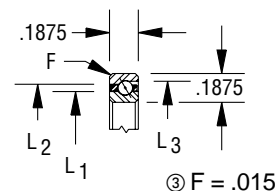
## Type A

### Angular Contact

A deep groove bearing with reduced shoulder on one side of inner or outer race ball path. Snapover assembly permits use of a one-piece circular pocket ring separator and greater ball complement. These bearings will accept radial load and single direction thrust load and are normally used in conjunction with another bearing of similar construction. Type A bearings require the application of thrust to establish contact angle. Stock bearings are individual units and when purchased as such must be adjusted at installation to desired running clearance or preload. When required, matched sets are available. Kaydon also offers matched spacers for applications requiring extra precision.

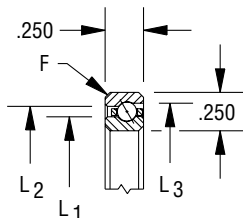
KAA SERIES										
Kaydon Bearing Number	Dimensions in Inches					Capacities in Pounds <sup>①</sup>				Weight in Pounds
	Bore	Outside Diameter	Land Dia. L <sub>1</sub>	Land Dia. L <sub>2</sub>	C'Bore Dia. L <sub>3</sub>	Radial		Thrust		
						Static <sup>②</sup>	Dyn.	Static <sup>②</sup>	Dyn.	
• KAA10AG0	1.000	1.375	1.140	1.235	1.274	340	150	970	450	.025
• KAA15AG0	1.500	1.875	1.640	1.735	1.774	480	200	1,380	560	.038
• KAA17AG0	1.750	2.125	1.890	1.985	2.024	530	210	1,520	600	.045

Circular pocket separator 3/32" balls



KA SERIES										
Kaydon Bearing Number	Dimensions in Inches					Capacities in Pounds <sup>①</sup>				Weight in Pounds
	Bore	Outside Diameter	Land Dia. L <sub>1</sub>	Land Dia. L <sub>2</sub>	C'Bore Dia. L <sub>3</sub>	Radial		Thrust		
						Static <sup>②</sup>	Dyn.	Static <sup>②</sup>	Dyn.	
• KA020AR0	2.000	2.500	2.186	2.314	2.369	790	330	2,280	960	.10
• KA025AR0	2.500	3.000	2.686	2.814	2.869	960	380	2,780	1,100	.12
• KA030AR0	3.000	3.500	3.186	3.314	3.367	1,140	430	3,290	1,230	.14
• KA035AR0	3.500	4.000	3.686	3.814	3.867	1,310	470	3,790	1,350	.17
• KA040AR0	4.000	4.500	4.186	4.314	4.367	1,490	510	4,300	1,470	.19
• KA042AR0	4.250	4.750	4.436	4.564	4.615	1,580	530	4,550	1,530	.20
• KA045AR0	4.500	5.000	4.686	4.814	4.865	1,660	550	4,810	1,580	.21
• KA047AR0	4.750	5.250	4.936	5.064	5.115	1,750	570	5,060	1,640	.22
• KA050AR0	5.000	5.500	5.186	5.314	5.365	1,840	590	5,310	1,690	.23
• KA055AR0	5.500	6.000	5.686	5.814	5.863	2,020	620	5,820	1,800	.25
• KA060AR0	6.000	6.500	6.186	6.314	6.363	2,190	660	6,320	1,900	.28
• KA065AR0	6.500	7.000	6.686	6.814	6.861	2,370	690	6,830	2,000	.30
• KA070AR0	7.000	7.500	7.186	7.314	7.361	2,540	730	7,340	2,100	.32
• KA075AR0	7.500	8.000	7.686	7.814	7.861	2,720	760	7,840	2,190	.34
• KA080AR0	8.000	8.500	8.186	8.314	8.359	2,890	790	8,350	2,280	.36
• KA090AR0	9.000	9.500	9.186	9.314	9.357	3,240	850	9,360	2,470	.41
• KA100AR0	10.000	10.500	10.186	10.314	10.355	3,590	910	10,370	2,640	.45
• KA110AR0	11.000	11.500	11.186	11.314	11.353	3,940	970	11,380	2,810	.50
• KA120AR0	12.000	12.500	12.186	12.314	12.349	4,290	1,030	12,390	2,970	.54

Circular pocket separator 1/8" balls



① Capacities listed are not simultaneous. For combined loading see discussion of Bearing Selection and Load Analysis. Dynamic capacities are based upon 1 million revolutions of L10 life. Published capacities do not apply to hybrid series bearings P, X, and Y - contact Kaydon product engineering for values.

② Static capacities are non-brinell limits based on rigid support from the shaft and housing.

③ "F" is the maximum shaft or housing fillet radius the bearing corners will clear.

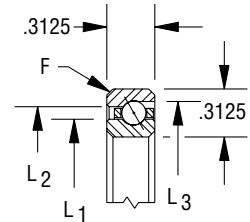
- Available from stock. All other - contact Kaydon for lead time.

**TYPE A - OPEN BEARINGS**

Section 2-Selection Tables

<b>KB SERIES</b>										
Kaydon Bearing Number	Dimensions in Inches					Capacities in Pounds <sup>①</sup>				Weight in Pounds
	Bore	Outside Diameter	Land Dia. L <sub>1</sub>	Land Dia. L <sub>2</sub>	C'Bore Dia. L <sub>3</sub>	Radial		Thrust		
						Static <sup>②</sup>	Dyn.	Static <sup>②</sup>	Dyn.	
• KB020AR0	2.000	2.625	2.231	2.393	2.464	1,090	480	3,150	1,380	.15
• KB025AR0	2.500	3.125	2.731	2.893	2.964	1,340	550	3,860	1,590	.19
• KB030AR0	3.000	3.625	3.231	3.393	3.462	1,550	610	4,470	1,750	.22
• KB035AR0	3.500	4.125	3.731	3.893	3.962	1,790	670	5,180	1,930	.27
• KB040AR0	4.000	4.625	4.231	4.393	4.460	2,040	730	5,890	2,100	.30
KB042AR0	4.250	4.875	4.481	4.643	4.710	2,150	750	6,200	2,170	.31
KB045AR0	4.500	5.125	4.731	4.893	4.960	2,250	780	6,500	2,240	.34
KB047AR0	4.750	5.375	4.981	5.143	5.210	2,390	810	6,910	2,340	.35
KB050AR0	5.000	5.625	5.231	5.393	5.460	2,500	830	7,210	2,410	.37
KB055AR0	5.500	6.125	5.731	5.893	5.958	2,740	890	7,920	2,560	.40
KB060AR0	6.000	6.625	6.231	6.393	6.458	2,990	940	8,630	2,710	.44
KB065AR0	6.500	7.125	6.731	6.893	6.958	3,200	980	9,240	2,840	.47
KB070AR0	7.000	7.625	7.231	7.393	7.456	3,450	1,030	9,960	2,980	.50
KB075AR0	7.500	8.125	7.731	7.893	7.955	3,700	1,080	10,670	3,120	.54
KB080AR0	8.000	8.625	8.231	8.393	8.453	3,940	1,130	11,380	3,260	.57
• KB090AR0	9.000	9.625	9.231	9.393	9.451	4,400	1,220	12,700	3,510	.64
KB100AR0	10.000	10.625	10.231	10.393	10.449	4,890	1,300	14,120	3,760	.71
KB110AR0	11.000	11.625	11.231	11.393	11.447	5,350	1,380	15,440	4,000	.78
KB120AR0	12.000	12.625	12.231	12.393	12.445	5,840	1,470	16,860	4,240	.85
KB140AR0	14.000	14.625	14.231	14.393	14.439	6,760	1,620	19,500	4,670	.98
KB160AR0	16.000	16.625	16.231	16.393	16.433	7,710	1,770	22,250	5,100	1.12
KB180AR0	18.000	18.625	18.231	18.393	18.425	8,660	1,910	24,990	5,510	1.26
KB200AR0	20.000	20.625	20.231	20.393	20.416	9,610	2,050	27,730	5,900	1.40

Circular pocket separator  
5/32" balls



③ F = .040  
Bearing corners are normally chamfered

① Capacities listed are not simultaneous. For combined loading see discussion of Bearing Selection and Load Analysis. Dynamic capacities are based upon 1 million revolutions of L10 life. Published capacities do not apply to hybrid series bearings P, X, and Y - contact Kaydon product engineering for values.

② Static capacities are non-brinell limits based on rigid support from the shaft and housing.

③ "F" is the maximum shaft or housing fillet radius the bearing corners will clear.

• Available from stock. All other - contact Kaydon for lead time.

**CONTACT KAYDON AT—**  
 Kaydon Corporation • Muskegon, Michigan 49443  
 Telephone: 231/755-3741 • Fax: 231/759-4102

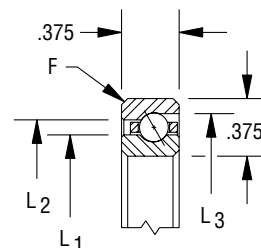
**NEED SERVICE FAST?**  
**1-800-514-3066**  
 Website: [www.real-slim.com](http://www.real-slim.com)



**TYPE A - OPEN BEARINGS**

<b>KC SERIES</b>										
Kaydon Bearing Number	Dimensions in Inches					Capacities in Pounds <sup>①</sup>				Weight in Pounds
	Bore	Outside Diameter	Land Dia. L <sub>1</sub>	Land Dia. L <sub>2</sub>	C'Bore Dia. L <sub>3</sub>	Radial		Thrust		
						Static <sup>②</sup>	Dyn.	Static <sup>②</sup>	Dyn.	
• KC040AR0	4.000	4.750	4.277	4.473	4.554	2,550	960	7,360	2,770	.44
KC042AR0	4.250	5.000	4.527	4.723	4.804	2,710	1,000	7,820	2,880	.46
• KC045AR0	4.500	5.250	4.777	4.973	5.052	2,860	1,040	8,270	2,990	.49
KC047AR0	4.750	5.500	5.027	5.223	5.302	3,020	1,070	8,720	3,100	.51
• KC050AR0	5.000	5.750	5.277	5.473	5.552	3,180	1,110	9,170	3,200	.54
KC055AR0	5.500	6.250	5.777	5.973	6.052	3,440	1,170	9,920	3,370	.58
• KC060AR0	6.000	6.750	6.277	6.473	6.550	3,750	1,240	10,820	3,580	.64
KC065AR0	6.500	7.250	6.777	6.973	7.050	4,060	1,310	11,720	3,770	.68
• KC070AR0	7.000	7.750	7.277	7.473	7.550	4,320	1,360	12,470	3,930	.74
KC075AR0	7.500	8.250	7.777	7.973	8.048	4,630	1,430	13,380	4,120	.78
KC080AR0	8.000	8.750	8.277	8.473	8.548	4,950	1,490	14,280	4,300	.84
KC090AR0	9.000	9.750	9.277	9.473	9.546	5,520	1,600	15,930	4,630	.98
KC100AR0	10.000	10.750	10.277	10.473	10.544	6,140	1,720	17,730	4,970	1.04
KC110AR0	11.000	11.750	11.277	11.473	11.542	6,720	1,830	19,390	5,280	1.14
KC120AR0	12.000	12.750	12.277	12.473	12.540	7,290	1,930	21,040	5,570	1.23
KC140AR0	14.000	14.750	14.277	14.473	14.535	8,490	2,140	24,500	6,170	1.43
KC160AR0	16.000	16.750	16.277	16.473	16.529	9,680	2,330	27,950	6,730	1.63
KC180AR0	18.000	18.750	18.277	18.473	18.523	10,880	2,520	31,410	7,280	1.83
KC200AR0	20.000	20.750	20.277	20.473	20.517	12,030	2,690	34,720	7,780	2.03
KC250AR0	25.000	25.750	25.277	25.473	25.500	14,900	3,120	43,280	9,010	2.52
KC300AR0	30.000	30.750	30.277	30.473	30.484	17,960	3,520	51,850	10,160	3.02

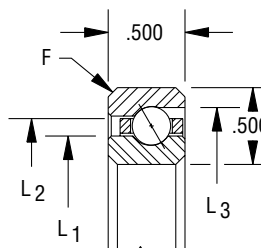
Circular pocket separator  
3/16" balls



③ F = .040  
Bearing corners are normally chamfered

<b>KD SERIES</b>										
Kaydon Bearing Number	Dimensions in Inches					Capacities in Pounds <sup>①</sup>				Weight in Pounds
	Bore	Outside Diameter	Land Dia. L <sub>1</sub>	Land Dia. L <sub>2</sub>	C'Bore Dia. L <sub>3</sub>	Radial		Thrust		
						Static <sup>②</sup>	Dyn.	Static <sup>②</sup>	Dyn.	
• KD040AR0	4.000	5.000	4.370	4.630	4.741	3,550	1,480	10,260	4,260	.80
• KD042AR0	4.250	5.250	4.620	4.880	4.991	3,750	1,530	10,830	4,420	.84
• KD045AR0	4.500	5.500	4.870	5.130	5.241	3,950	1,580	11,400	4,570	.88
• KD047AR0	4.750	5.750	5.120	5.380	5.490	4,150	1,640	11,970	4,720	.93
• KD050AR0	5.000	6.000	5.370	5.630	5.740	4,340	1,690	12,540	4,870	.98
• KD055AR0	5.500	6.500	5.870	6.130	6.238	4,740	1,790	13,680	5,160	1.06
• KD060AR0	6.000	7.000	6.370	6.630	6.738	5,130	1,890	14,820	5,440	1.15
• KD065AR0	6.500	7.500	6.870	7.130	7.236	5,530	1,980	15,960	5,720	1.24
• KD070AR0	7.000	8.000	7.370	7.630	7.736	5,920	2,070	17,100	5,990	1.33
KD075AR0	7.500	8.500	7.870	8.130	8.236	6,320	2,170	18,240	6,250	1.42
• KD080AR0	8.000	9.000	8.370	8.630	8.734	6,710	2,260	19,380	6,510	1.52
• KD090AR0	9.000	10.000	9.370	9.630	9.732	7,500	2,430	21,660	7,010	1.69
KD100AR0	10.000	11.000	10.370	10.630	10.732	8,290	2,600	23,940	7,500	1.87
KD110AR0	11.000	12.000	11.370	11.630	11.730	9,080	2,760	26,220	7,960	2.05
KD120AR0	12.000	13.000	12.370	12.630	12.728	9,870	2,920	28,500	8,420	2.23
KD140AR0	14.000	15.000	14.370	14.630	14.724	11,450	3,220	33,060	9,290	2.57
KD160AR0	16.000	17.000	16.370	16.630	16.718	13,030	3,510	37,620	10,130	2.93
KD180AR0	18.000	19.000	18.370	18.630	18.712	14,610	3,790	42,180	10,930	3.29
KD200AR0	20.000	21.000	20.370	20.630	20.705	16,190	4,060	46,740	11,710	3.65
KD250AR0	25.000	26.000	25.370	25.630	25.688	20,140	4,690	58,140	13,540	4.54
KD300AR0	30.000	31.000	30.370	30.630	30.672	24,090	5,290	69,540	15,260	5.44

Circular pocket separator  
1/4" balls



③ F = .060  
Bearing corners are normally chamfered

① Capacities listed are not simultaneous. For combined loading see discussion of Bearing Selection and Load Analysis. Dynamic capacities are based upon 1 million revolutions of L10 life. Published capacities do not apply to hybrid series bearings P, X, and Y - contact Kaydon product engineering for values.

② Static capacities are non-brinell limits based on rigid support from the shaft and housing.

③ "F" is the maximum shaft or housing fillet radius the bearing corners will clear.

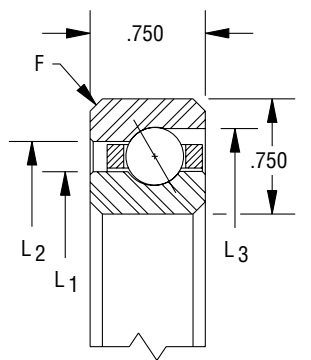
• Available from stock. All other - contact Kaydon for lead time.

**TYPE A - OPEN BEARINGS**

Section 2 - Selection Tables

<b>KF SERIES</b>										
Kaydon Bearing Number	Dimensions in Inches					Capacities in Pounds <sup>①</sup>				Weight in Pounds
	Bore	Outside Diameter	Land Dia. L <sub>1</sub>	Land Dia. L <sub>2</sub>	C'Bore Dia. L <sub>3</sub>	Radial		Thrust		
						Static <sup>②</sup>	Dyn.	Static <sup>②</sup>	Dyn.	
KF040AR0	4.000	5.500	4.555	4.945	5.115	6,350	2,920	18,340	8,420	1.92
KF042AR0	4.250	5.750	4.805	5.195	5.365	6,600	2,990	19,050	8,630	2.04
KF045AR0	4.500	6.000	5.060	5.445	5.615	7,090	3,140	20,460	9,050	2.14
•KF047AR0	4.750	6.250	5.305	5.695	5.865	7,330	3,210	21,160	9,260	2.26
KF050AR0	5.000	6.500	5.555	5.945	6.115	7,570	3,280	21,870	9,460	2.37
•KF055AR0	5.500	7.000	6.055	6.445	6.613	8,310	3,490	23,980	10,060	2.59
KF060AR0	6.000	7.500	6.555	6.945	7.113	9,040	3,690	26,100	10,650	2.72
•KF065AR0	6.500	8.000	7.055	7.445	7.613	9,770	3,890	28,220	11,220	2.94
KF070AR0	7.000	8.500	7.555	7.945	8.113	10,510	4,080	30,330	11,770	3.16
KF075AR0	7.500	9.000	8.055	8.445	8.610	11,000	4,200	31,740	12,130	3.39
•KF080AR0	8.000	9.500	8.555	8.945	9.110	11,730	4,390	33,860	12,670	3.61
KF090AR0	9.000	10.500	9.555	9.945	10.108	13,190	4,750	38,090	13,700	3.95
KF100AR0	10.000	11.500	10.555	10.945	11.106	14,420	5,030	41,620	14,530	4.40
KF110AR0	11.000	12.500	11.555	11.945	12.106	15,880	5,370	45,850	15,500	4.75
•KF120AR0	12.000	13.500	12.555	12.945	13.104	17,100	5,640	49,380	16,290	5.20
KF140AR0	14.000	15.500	14.555	14.945	15.102	19,790	6,220	57,140	17,950	5.76
KF160AR0	16.000	17.500	16.555	16.945	17.098	22,480	6,770	64,890	19,540	6.78
KF180AR0	18.000	19.500	18.555	18.945	19.096	25,410	7,350	73,360	21,210	7.67
KF200AR0	20.000	21.500	20.555	20.945	21.092	28,100	7,860	81,120	22,680	8.47
KF250AR0	25.000	26.500	25.555	25.945	26.085	34,700	9,040	100,200	26,100	10.50
KF300AR0	30.000	31.500	30.555	30.945	31.075	41,540	10,190	119,900	29,430	12.50
KF350AR0	35.000	36.500	35.555	35.945	36.064	48,380	11,290	139,700	32,580	14.60
KF400AR0	40.000	41.500	40.555	40.945	41.054	55,220	12,330	159,400	35,580	16.60

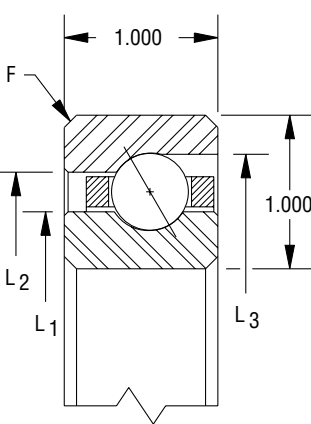
Circular pocket separator  
3/8" balls



③ F = .080  
Bearing corners are normally chamfered

<b>KG SERIES</b>										
Kaydon Bearing Number	Dimensions in Inches					Capacities in Pounds <sup>①</sup>				Weight in Pounds
	Bore	Outside Diameter	Land Dia. L <sub>1</sub>	Land Dia. L <sub>2</sub>	C'Bore Dia. L <sub>3</sub>	Radial		Thrust		
						Static <sup>②</sup>	Dyn.	Static <sup>②</sup>	Dyn.	
KG040AR0	4.000	6.000	4.742	5.258	5.491	9,480	4,720	27,360	13,630	3.61
KG042AR0	4.250	6.250	4.992	5.508	5.741	9,950	4,880	28,730	14,090	3.83
KG045AR0	4.500	6.500	5.242	5.758	5.989	10,430	5,030	30,100	14,530	3.95
KG047AR0	4.750	6.750	5.492	6.008	6.239	10,900	5,180	31,460	14,970	4.17
KG050AR0	5.000	7.000	5.742	6.258	6.489	11,370	5,330	32,830	15,400	4.42
•KG055AR0	5.500	7.500	6.242	6.758	6.989	12,320	5,630	35,570	16,240	4.73
•KG060AR0	6.000	8.000	6.742	7.258	7.489	13,270	5,910	38,300	17,060	5.07
•KG065AR0	6.500	8.500	7.242	7.758	7.987	14,220	6,190	41,040	17,870	5.41
•KG070AR0	7.000	9.000	7.742	8.258	8.487	15,160	6,460	43,780	18,650	5.87
•KG075AR0	7.500	9.500	8.242	8.758	8.987	16,110	6,730	46,510	19,420	6.20
•KG080AR0	8.000	10.000	8.742	9.258	9.485	17,060	6,990	49,250	20,180	6.54
•KG090AR0	9.000	11.000	9.742	10.258	10.485	18,960	7,500	54,720	21,640	7.22
KG100AR0	10.000	12.000	10.742	11.258	11.483	20,850	7,990	60,190	23,060	8.00
KG110AR0	11.000	13.000	11.742	12.258	12.481	22,750	8,470	65,660	24,440	8.68
•KG120AR0	12.000	14.000	12.742	13.258	13.481	24,640	8,930	71,140	25,780	9.47
•KG140AR0	14.000	16.000	14.742	15.258	15.478	28,430	9,820	82,080	28,360	10.90
•KG160AR0	16.000	18.000	16.742	17.258	17.474	32,220	10,680	93,020	30,830	12.40
•KG180AR0	18.000	20.000	18.742	19.258	19.472	36,020	11,500	104,000	33,200	13.80
•KG200AR0	20.000	22.000	20.742	21.258	21.468	39,810	12,300	114,900	35,490	15.20
•KG250AR0	25.000	27.000	25.742	26.258	26.461	49,280	14,180	142,300	40,920	18.80
KG300AR0	30.000	32.000	30.742	31.258	31.451	58,760	15,940	169,600	46,020	22.50
KG350AR0	35.000	37.000	35.742	36.258	36.440	68,240	17,610	197,000	50,840	26.20
KG400AR0	40.000	42.000	40.742	41.258	41.430	77,720	19,210	224,400	55,440	29.80

Circular pocket separator  
1/2" balls



③ F = .080  
Bearing corners are normally chamfered

① Capacities listed are not simultaneous. For combined loading see discussion of Bearing Selection and Load Analysis. Dynamic capacities are based upon 1 million revolutions of L10 life. Published capacities do not apply to hybrid series bearings P, X, and Y - contact Kaydon product engineering for values.  
 ② Static capacities are non-brinell limits based on rigid support from the shaft and housing.  
 ③ "F" is the maximum shaft or housing fillet radius the bearing corners will clear.  
 • Available from stock. All other - contact Kaydon for lead time.

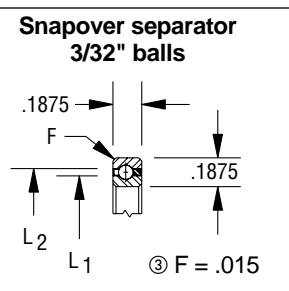
# Open Bearing Selections

## Type C

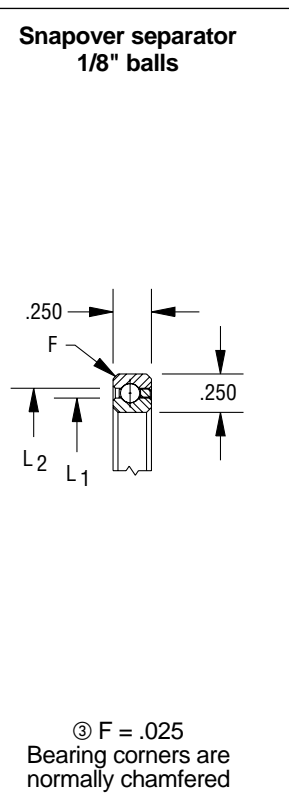
### Radial Contact

A Conrad assembled bearing designed primarily for application of radial load—deep ball grooves also permit application of thrust load in either direction – often used in conjunction with another bearing.

KAA SERIES							
Kaydon Bearing Number	Dimensions in Inches				Radial Capacity (lbs.) <sup>①</sup>		Weight in Pounds
	Bore	Outside Diameter	Land Dia. L <sub>1</sub>	Land Dia. L <sub>2</sub>	Static <sup>②</sup>	Dynamic	
• KAA10CL0	1.000	1.375	1.140	1.235	290	150	.026
• KAA15CL0	1.500	1.875	1.640	1.735	400	180	.039
• KAA17CL0	1.750	2.125	1.890	1.985	460	200	.045



KA SERIES							
Kaydon Bearing Number	Dimensions in Inches				Radial Capacity (lbs.) <sup>①</sup>		Weight in Pounds
	Bore	Outside Diameter	Land Dia. L <sub>1</sub>	Land Dia. L <sub>2</sub>	Static <sup>②</sup>	Dynamic	
• KA020CP0	2.000	2.500	2.186	2.314	680	320	.10
• KA025CP0	2.500	3.000	2.686	2.814	830	360	.13
• KA030CP0	3.000	3.500	3.186	3.314	990	410	.15
• KA035CP0	3.500	4.000	3.686	3.814	1,140	450	.18
• KA040CP0	4.000	4.500	4.186	4.314	1,290	480	.19
• KA042CP0	4.250	4.750	4.436	4.564	1,370	500	.20
• KA045CP0	4.500	5.000	4.686	4.814	1,440	520	.22
• KA047CP0	4.750	5.250	4.936	5.064	1,520	540	.23
• KA050CP0	5.000	5.500	5.186	5.314	1,590	560	.24
• KA055CP0	5.500	6.000	5.686	5.814	1,750	590	.25
• KA060CP0	6.000	6.500	6.186	6.314	1,900	630	.28
• KA065CP0	6.500	7.000	6.686	6.814	2,050	660	.30
• KA070CP0	7.000	7.500	7.186	7.314	2,200	690	.31
• KA075CP0	7.500	8.000	7.686	7.814	2,350	720	.34
• KA080CP0	8.000	8.500	8.186	8.314	2,500	750	.38
• KA090CP0	9.000	9.500	9.186	9.314	2,810	810	.44
• KA100CP0	10.000	10.500	10.186	10.314	3,110	870	.50
• KA110CP0	11.000	11.500	11.186	11.314	3,410	930	.52
• KA120CP0	12.000	12.500	12.186	12.314	3,720	980	.56



① Capacities listed are not simultaneous. For combined loading see discussion of Bearing Selection and Load Analysis. Dynamic capacities are based upon 1 million revolutions of L10 life. Published capacities do not apply to hybrid series bearings P, X, and Y - contact Kaydon product engineering for values.

② Static capacities are non-brinell limits based on rigid support from the shaft and housing.

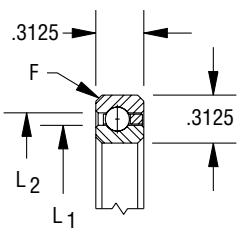
③ "F" is the maximum shaft or housing fillet radius the bearing corners will clear.

- Available from stock. All other – contact Kaydon for lead time.

**TYPE C - OPEN BEARINGS**

Section 2-Selection Tables

<b>KB SERIES</b>								Snapover separator 5/32" balls
Kaydon Bearing Number	Dimensions in Inches				Radial Capacity (lbs.) <sup>①</sup>		Weight in Pounds	
	Bore	Outside Diameter	Land Dia. L <sub>1</sub>	Land Dia. L <sub>2</sub>	Static <sup>②</sup>	Dynamic		
• KB020CP0	2.000	2.625	2.231	2.393	930	450	.16	
• KB025CP0	2.500	3.125	2.731	2.893	1,140	520	.20	
• KB030CP0	3.000	3.625	3.231	3.393	1,340	580	.24	
• KB035CP0	3.500	4.125	3.731	3.893	1,540	630	.27	
• KB040CP0	4.000	4.625	4.231	4.393	1,750	690	.30	
• KB042CP0	4.250	4.875	4.481	4.643	1,830	710	.31	
• KB045CP0	4.500	5.125	4.731	4.893	1,950	740	.33	
• KB047CP0	4.750	5.375	4.981	5.143	2,030	760	.34	
• KB050CP0	5.000	5.625	5.231	5.393	2,150	790	.38	
• KB055CP0	5.500	6.125	5.731	5.893	2,360	840	.41	
• KB060CP0	6.000	6.625	6.231	6.393	2,560	890	.44	
• KB065CP0	6.500	7.125	6.731	6.893	2,760	930	.47	
• KB070CP0	7.000	7.625	7.231	7.393	2,970	980	.50	
• KB075CP0	7.500	8.125	7.731	7.893	3,170	1,020	.53	
• KB080CP0	8.000	8.625	8.231	8.393	3,370	1,070	.57	
• KB090CP0	9.000	9.625	9.231	9.393	3,780	1,150	.66	
• KB100CP0	10.000	10.625	10.231	10.393	4,190	1,230	.73	
• KB110CP0	11.000	11.625	11.231	11.393	4,590	1,310	.75	
• KB120CP0	12.000	12.625	12.231	12.393	5,000	1,390	.83	
• KB140CP0	14.000	14.625	14.231	14.393	5,810	1,530	1.05	
• KB160CP0	16.000	16.625	16.231	16.393	6,620	1,670	1.20	
• KB180CP0	18.000	18.625	18.231	18.393	7,440	1,810	1.35	
• KB200CP0	20.000	20.625	20.231	20.393	8,250	1,940	1.50	



③ F = .040  
Bearing corners are normally chamfered

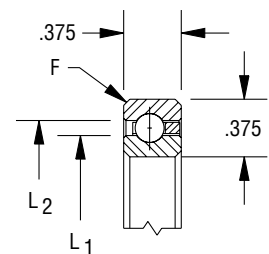
- ① Capacities listed are not simultaneous. For combined loading see discussion of Bearing Selection and Load Analysis. Dynamic capacities are based upon 1 million revolutions of L10 life. Published capacities do not apply to hybrid series bearings P, X, and Y - contact Kaydon product engineering for values.
- ② Static capacities are non-brinell limits based on rigid support from the shaft and housing.
- ③ "F" is the maximum shaft or housing fillet radius the bearing corners will clear.
  - Available from stock. All other - contact Kaydon for lead time.

**CONTACT KAYDON AT—**  
 Kaydon Corporation • Muskegon, Michigan 49443  
 Telephone: 231/755-3741 • Fax: 231/759-4102

**NEED SERVICE FAST?**  
**1-800-514-3066**  
 Website: [www.real-slim.com](http://www.real-slim.com)

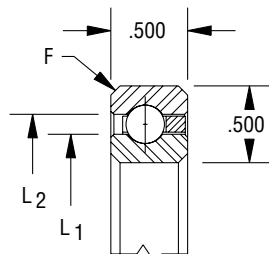
**TYPE C - OPEN BEARINGS**

<b>KC SERIES</b>								Snapover separator 3/16" balls
Kaydon Bearing Number	Dimensions in Inches				Radial Capacity (lbs.) <sup>①</sup>		Weight in Pounds	
	Bore	Outside Diameter	Land Dia. L <sub>1</sub>	Land Dia. L <sub>2</sub>	Static <sup>②</sup>	Dynamic		
• KC040CP0	4.000	4.750	4.277	4.473	2,100	880	.45	
• KC042CP0	4.250	5.000	4.527	4.723	2,220	920	.47	
• KC045CP0	4.500	5.250	4.777	4.973	2,340	950	.48	
• KC047CP0	4.750	5.500	5.027	5.223	2,460	980	.50	
• KC050CP0	5.000	5.750	5.277	5.473	2,590	1,010	.58	
• KC055CP0	5.500	6.250	5.777	5.973	2,830	1,080	.59	
• KC060CP0	6.000	6.750	6.277	6.473	3,070	1,140	.63	
• KC065CP0	6.500	7.250	6.777	6.973	3,310	1,200	.68	
• KC070CP0	7.000	7.750	7.277	7.473	3,550	1,250	.73	
• KC075CP0	7.500	8.250	7.777	7.973	3,790	1,310	.78	
• KC080CP0	8.000	8.750	8.277	8.473	4,030	1,360	.84	
• KC090CP0	9.000	9.750	9.277	9.473	4,510	1,470	.94	
• KC100CP0	10.000	10.750	10.277	10.473	4,990	1,570	1.06	
• KC110CP0	11.000	11.750	11.277	11.473	5,470	1,670	1.16	
• KC120CP0	12.000	12.750	12.277	12.473	5,950	1,770	1.25	
• KC140CP0	14.000	14.750	14.277	14.473	6,910	1,950	1.52	
• KC160CP0	16.000	16.750	16.277	16.473	7,880	2,130	1.73	
• KC180CP0	18.000	18.750	18.277	18.473	8,840	2,300	1.94	
• KC200CP0	20.000	20.750	20.277	20.473	9,800	2,470	2.16	
• KC250CP0	25.000	25.750	25.277	25.473	12,200	2,850	2.69	
• KC300CP0	30.000	30.750	30.277	30.473	14,610	3,220	3.21	



③ F = .040  
Bearing corners are normally chamfered

<b>KD SERIES</b>								Snapover separator 1/4" balls
Kaydon Bearing Number	Dimensions in Inches				Radial Capacity (lbs.) <sup>①</sup>		Weight in Pounds	
	Bore	Outside Diameter	Land Dia. L <sub>1</sub>	Land Dia. L <sub>2</sub>	Static <sup>②</sup>	Dynamic		
• KD040CP0	4.000	5.000	4.370	4.630	3,080	1,410	.78	
• KD042CP0	4.250	5.250	4.620	4.880	3,190	1,440	.83	
• KD045CP0	4.500	5.500	4.870	5.130	3,420	1,510	.88	
• KD047CP0	4.750	5.750	5.120	5.380	3,530	1,540	.94	
• KD050CP0	5.000	6.000	5.370	5.630	3,760	1,610	1.00	
• KD055CP0	5.500	6.500	5.870	6.130	4,100	1,700	1.06	
• KD060CP0	6.000	7.000	6.370	6.630	4,450	1,800	1.16	
• KD065CP0	6.500	7.500	6.870	7.130	4,790	1,890	1.22	
• KD070CP0	7.000	8.000	7.370	7.630	5,130	1,980	1.31	
• KD075CP0	7.500	8.500	7.870	8.130	5,470	2,060	1.41	
• KD080CP0	8.000	9.000	8.370	8.630	5,810	2,150	1.53	
• KD090CP0	9.000	10.000	9.370	9.630	6,500	2,320	1.72	
• KD100CP0	10.000	11.000	10.370	10.630	7,180	2,470	1.88	
• KD110CP0	11.000	12.000	11.370	11.630	7,870	2,630	2.06	
• KD120CP0	12.000	13.000	12.370	12.630	8,550	2,780	2.25	
• KD140CP0	14.000	15.000	14.370	14.630	9,920	3,070	2.73	
• KD160CP0	16.000	17.000	16.370	16.630	11,290	3,350	3.10	
• KD180CP0	18.000	19.000	18.370	18.630	12,650	3,610	3.48	
• KD200CP0	20.000	21.000	20.370	20.630	14,020	3,870	3.85	
• KD250CP0	25.000	26.000	25.370	25.630	17,440	4,470	4.79	
• KD300CP0	30.000	31.000	30.370	30.360	20,860	5,040	5.73	



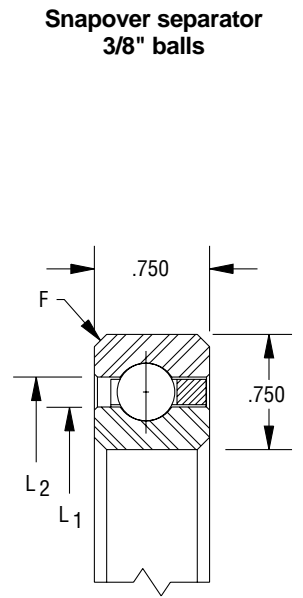
③ F = .060  
Bearing corners are normally chamfered

① Capacities listed are not simultaneous. For combined loading see discussion of Bearing Selection and Load Analysis. Dynamic capacities are based upon 1 million revolutions of L10 life. Published capacities do not apply to hybrid series bearings P, X, and Y - contact Kaydon product engineering for values.  
 ② Static capacities are non-brinell limits based on rigid support from the shaft and housing.  
 ③ "F" is the maximum shaft or housing fillet radius the bearing corners will clear.  
 • Available from stock. All other - contact Kaydon for lead time.

**TYPE C - OPEN BEARINGS**

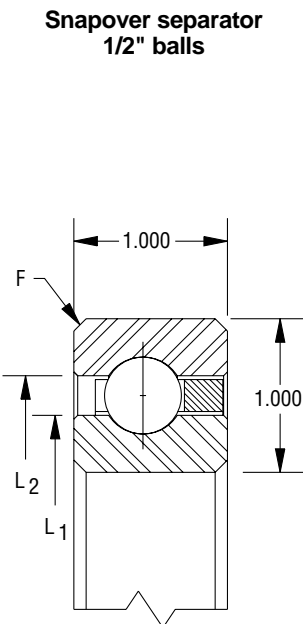
Section 2-Selection Tables

<b>KF SERIES</b>							
Kaydon Bearing Number	Dimensions in Inches				Radial Capacity (lbs.) <sup>①</sup>		Weight in Pounds
	Bore	Outside Diameter	Land Dia. L <sub>1</sub>	Land Dia. L <sub>2</sub>	Static <sup>②</sup>	Dynamic	
• KF040CP0	4.000	5.500	4.555	4.945	5,360	2,730	1.9
• KF042CP0	4.250	5.750	4.805	5.195	5,640	2,830	2.0
• KF045CP0	4.500	6.000	5.055	5.445	5,930	2,920	2.1
• KF047CP0	4.750	6.250	5.305	5.695	6,210	3,010	2.2
• KF050CP0	5.000	6.500	5.555	5.945	6,490	3,100	2.3
• KF055CP0	5.500	7.000	6.055	6.445	7,050	3,280	2.5
• KF060CP0	6.000	7.500	6.555	6.945	7,620	3,450	2.7
• KF065CP0	6.500	8.000	7.055	7.445	8,180	3,620	2.9
• KF070CP0	7.000	8.500	7.555	7.945	8,750	3,790	3.2
• KF075CP0	7.500	9.000	8.055	8.445	9,310	3,950	3.4
• KF080CP0	8.000	9.500	8.555	8.945	9,880	4,100	3.5
• KF090CP0	9.000	10.500	9.555	9.945	11,000	4,410	3.9
• KF100CP0	10.000	11.500	10.555	10.945	12,130	4,710	4.3
• KF110CP0	11.000	12.500	11.555	11.945	13,260	5,000	4.8
• KF120CP0	12.000	13.500	12.555	12.945	14,390	5,280	5.2
KF140CP0	14.000	15.500	14.555	14.945	16,650	5,810	6.0
KF160CP0	16.000	17.500	16.555	16.945	18,900	6,330	7.1
KF180CP0	18.000	19.500	18.555	18.945	21,160	6,820	7.9
KF200CP0	20.000	21.500	20.555	20.945	23,420	7,300	8.9
KF250CP0	25.000	26.500	25.555	25.945	29,060	8,430	10.9
KF300CP0	30.000	31.500	30.555	30.945	34,700	9,490	13.0
KF350CP0	35.000	36.500	35.555	35.945	40,350	10,490	15.1
KF400CP0	40.000	41.500	40.555	40.945	45,990	11,450	17.2



③ F = .080  
Bearing corners are normally chamfered

<b>KG SERIES</b>							
Kaydon Bearing Number	Dimensions in Inches				Radial Capacity (lbs.) <sup>①</sup>		Weight in Pounds
	Bore	Outside Diameter	Land Dia. L <sub>1</sub>	Land Dia. L <sub>2</sub>	Static <sup>②</sup>	Dynamic	
KG040CP0	4.000	6.000	4.742	5.258	8,210	4,500	3.6
KG042CP0	4.250	6.250	4.992	5.508	8,210	4,500	3.8
KG045CP0	4.500	6.500	5.242	5.758	8,760	4,700	4.0
KG047CP0	4.750	6.750	5.492	6.008	9,300	4,890	4.1
• KG050CP0	5.000	7.000	5.742	6.258	9,850	5,080	4.3
• KG055CP0	5.500	7.500	6.242	6.758	10,400	5,270	4.7
• KG060CP0	6.000	8.000	6.742	7.258	11,490	5,630	5.1
• KG065CP0	6.500	8.500	7.242	7.758	12,040	5,810	5.4
• KG070CP0	7.000	9.000	7.742	8.258	13,130	6,160	5.8
• KG075CP0	7.500	9.500	8.242	8.758	13,680	6,330	6.1
• KG080CP0	8.000	10.000	8.742	9.258	14,770	6,660	6.5
• KG090CP0	9.000	11.000	9.742	10.258	16,420	7,150	7.2
• KG100CP0	10.000	12.000	10.742	11.258	18,060	7,620	7.9
• KG110CP0	11.000	13.000	11.742	12.258	19,700	8,070	8.6
• KG120CP0	12.000	14.000	12.742	13.258	21,340	8,510	9.3
• KG140CP0	14.000	16.000	14.742	15.258	24,620	9,360	10.8
• KG160CP0	16.000	18.000	16.742	17.258	27,910	10,180	12.3
• KG180CP0	18.000	20.000	18.742	19.258	31,190	10,960	13.7
KG200CP0	20.000	22.000	20.742	21.258	34,470	11,720	15.8
KG250CP0	25.000	27.000	25.742	26.258	42,680	13,510	19.5
KG300CP0	30.000	32.000	30.742	31.258	50,890	15,190	23.3
KG350CP0	35.000	37.000	35.742	36.258	59,100	16,790	27.1
KG400CP0	40.000	42.000	40.742	41.258	67,310	18,310	30.8



③ F = .080  
Bearing corners are normally chamfered

① Capacities listed are not simultaneous. For combined loading see discussion of Bearing Selection and Load Analysis. Dynamic capacities are based upon 1 million revolutions of L10 life. Published capacities do not apply to hybrid series bearings P, X, and Y - contact Kaydon product engineering for values.  
 ② Static capacities are non-brinell limits based on rigid support from the shaft and housing.  
 ③ "F" is the maximum shaft or housing fillet radius the bearing corners will clear.  
 • Available from stock. All other - contact Kaydon for lead time.

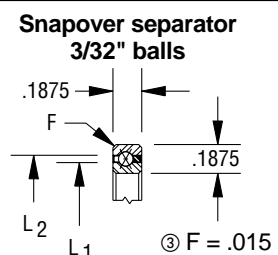
# Open Bearing Selections

## Type X

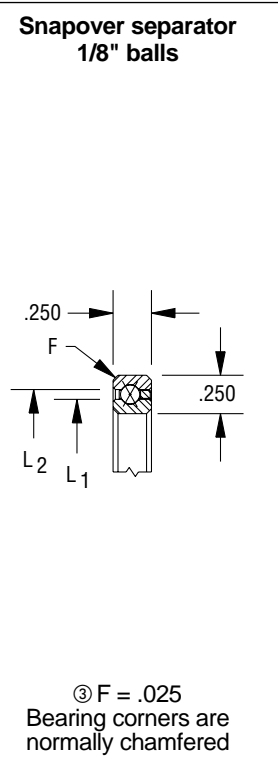
### Four-Point Contact

A Conrad assembled bearing designed for applications involving multiple loads. Unique internal geometry permits application of radial load, thrust load in either direction, and moment load, individually or in any combination. A single four-point contact bearing may replace two bearings in many applications.

KAA SERIES											
Kaydon Bearing Number	Dimensions in Inches				Capacities <sup>①</sup>						Weight in Pounds
	Bore	Outside Diameter	Land Dia. L <sub>1</sub>	Land Dia. L <sub>2</sub>	Radial in Pounds		Thrust in Pounds		Moment (Lbs-In)		
					Static <sup>②</sup>	Dyn.	Static <sup>②</sup>	Dyn.	Static <sup>②</sup>	Dyn.	
•KAA10XL0	1.000	1.375	1.140	1.235	290	150	730	370	170	90	.026
•KAA15XL0	1.500	1.875	1.640	1.735	400	180	1,000	460	340	150	.039
•KAA17XL0	1.750	2.125	1.890	1.985	460	200	1,140	500	440	190	.045



KA SERIES											
Kaydon Bearing Number	Dimensions in Inches				Capacities <sup>①</sup>						Weight in Pounds
	Bore	Outside Diameter	Land Dia. L <sub>1</sub>	Land Dia. L <sub>2</sub>	Radial in Pounds		Thrust in Pounds		Moment (Lbs-In)		
					Static <sup>②</sup>	Dyn.	Static <sup>②</sup>	Dyn.	Static <sup>②</sup>	Dyn.	
•KA020XP0	2.000	2.500	2.186	2.314	680	320	1,710	790	770	360	.10
•KA025XP0	2.500	3.000	2.686	2.814	830	360	2,090	910	1,150	500	.13
•KA030XP0	3.000	3.500	3.186	3.314	990	410	2,470	1,010	1,600	660	.15
•KA035XP0	3.500	4.000	3.686	3.814	1,140	450	2,850	1,110	2,130	840	.18
•KA040XP0	4.000	4.500	4.186	4.314	1,290	480	3,220	1,210	2,740	1,030	.19
KA042XP0	4.250	4.750	4.436	4.564	1,370	500	3,410	1,260	3,070	1,130	.20
•KA045XP0	4.500	5.000	4.686	4.814	1,440	520	3,600	1,310	3,420	1,240	.22
•KA047XP0	4.750	5.250	4.936	5.064	1,520	540	3,790	1,350	3,790	1,350	.23
•KA050XP0	5.000	5.500	5.186	5.314	1,590	560	3,980	1,400	4,180	1,460	.24
•KA055XP0	5.500	6.000	5.686	5.814	1,750	590	4,360	1,480	5,020	1,700	.25
•KA060XP0	6.000	6.500	6.186	6.314	1,900	630	4,740	1,570	5,930	1,960	.28
•KA065XP0	6.500	7.000	6.686	6.814	2,050	660	5,120	1,650	6,910	2,230	.30
•KA070XP0	7.000	7.500	7.186	7.314	2,200	690	5,500	1,730	7,980	2,510	.31
•KA075XP0	7.500	8.000	7.686	7.814	2,350	720	5,880	1,810	9,120	2,800	.34
KA080XP0	8.000	8.500	8.186	8.314	2,500	750	6,260	1,890	10,330	3,110	.38
KA090XP0	9.000	9.500	9.186	9.314	2,810	810	7,020	2,040	12,990	3,770	.44
•KA100XP0	10.000	10.500	10.186	10.314	3,110	870	7,780	2,180	15,940	4,470	.50
KA110XP0	11.000	11.500	11.186	11.314	3,410	930	8,540	2,320	19,210	5,220	.52
•KA120XP0	12.000	12.500	12.186	12.314	3,720	980	9,300	2,450	22,770	6,010	.56



① Capacities listed are not simultaneous. For combined loading see discussion of Bearing Selection and Load Analysis. Dynamic capacities are based upon 1 million revolutions of L10 life. Published capacities do not apply to hybrid series bearings P, X, and Y - contact Kaydon product engineering for values.

② Static capacities are non-brinell limits based on rigid support from the shaft and housing.

③ "F" is the maximum shaft or housing fillet radius the bearing corners will clear.

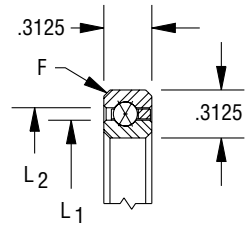
• Available from stock. All other - contact Kaydon for lead time.

**TYPE X - OPEN BEARINGS**

Section 2-Selection Tables

<b>KB SERIES</b>											
Kaydon Bearing Number	Dimensions in Inches				Capacities ①						Weight in Pounds
	Bore	Outside Diameter	Land Dia. L <sub>1</sub>	Land Dia. L <sub>2</sub>	Radial in Pounds		Thrust in Pounds		Moment (Lbs-In)		
					Static②	Dyn.	Static②	Dyn.	Static②	Dyn.	
• KB020XP0	2.000	2.625	2.231	2.393	930	450	2,340	1,130	1,080	520	.16
• KB025XP0	2.500	3.125	2.731	2.893	1,140	520	2,840	1,290	1,600	730	.19
• KB030XP0	3.000	3.625	3.231	3.393	1,340	580	3,350	1,440	2,220	960	.24
• KB035XP0	3.500	4.125	3.731	3.893	1,540	630	3,860	1,590	2,940	1,210	.27
• KB040XP0	4.000	4.625	4.231	4.393	1,750	690	4,370	1,720	3,770	1,490	.30
• KB042XP0	4.250	4.875	4.481	4.643	1,830	710	4,570	1,780	4,170	1,620	.31
• KB045XP0	4.500	5.125	4.731	4.893	1,950	740	4,880	1,850	4,690	1,780	.33
KB047XP0	4.750	5.375	4.981	5.143	2,030	760	5,080	1,900	5,140	1,930	.34
• KB050XP0	5.000	5.625	5.231	5.393	2,150	790	5,380	1,980	5,720	2,100	.38
• KB055XP0	5.500	6.125	5.731	5.893	2,360	840	5,890	2,100	6,850	2,440	.41
• KB060XP0	6.000	6.625	6.231	6.393	2,560	890	6,400	2,220	8,080	2,800	.44
• KB065XP0	6.500	7.125	6.731	6.893	2,760	930	6,910	2,340	9,410	3,180	.47
KB070XP0	7.000	7.625	7.231	7.393	2,970	980	7,420	2,450	10,850	3,580	.50
KB075XP0	7.500	8.125	7.731	7.893	3,170	1,020	7,920	2,560	12,380	4,000	.53
• KB080XP0	8.000	8.625	8.231	8.393	3,370	1,070	8,430	2,670	14,020	4,440	.57
• KB090XP0	9.000	9.625	9.231	9.393	3,780	1,150	9,450	2,880	17,600	5,360	.66
KB100XP0	10.000	10.625	10.231	10.393	4,190	1,230	10,460	3,080	21,580	6,360	.73
KB110XP0	11.000	11.625	11.231	11.393	4,590	1,310	11,480	3,280	25,970	7,420	.75
KB120XP0	12.000	12.625	12.231	12.393	5,000	1,390	12,500	3,470	30,770	8,550	.83
KB140XP0	14.000	14.625	14.231	14.393	5,810	1,530	14,530	3,840	41,580	10,980	1.05
KB160XP0	16.000	16.625	16.231	16.393	6,620	1,670	16,560	4,190	54,020	13,660	1.20
KB180XP0	18.000	18.625	18.231	18.393	7,440	1,810	18,590	4,520	68,090	16,560	1.35
KB200XP0	20.000	20.625	20.231	20.393	8,250	1,940	20,620	4,850	83,780	19,690	1.50

Snapover separator  
5/32" balls



③ F = .040  
Bearing corners are normally chamfered

- ① Capacities listed are not simultaneous. For combined loading see discussion of Bearing Selection and Load Analysis. Dynamic capacities are based upon 1 million revolutions of L10 life. Published capacities do not apply to hybrid series bearings P, X, and Y - contact Kaydon product engineering for values.
- ② Static capacities are non-brinell limits based on rigid support from the shaft and housing.
- ③ "F" is the maximum shaft or housing fillet radius the bearing corners will clear.
  - Available from stock. All other - contact Kaydon for lead time.

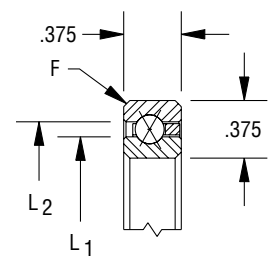
**CONTACT KAYDON AT—**  
 Kaydon Corporation • Muskegon, Michigan 49443  
 Telephone: 231/755-3741 • Fax: 231/759-4102

**NEED SERVICE FAST?**  
**1-800-514-3066**  
 Website: [www.real-slim.com](http://www.real-slim.com)



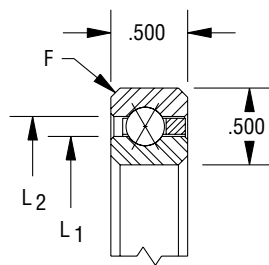
**TYPE X - OPEN BEARINGS**

<b>KC SERIES</b>												Snapover separator 3/16" balls
Kaydon Bearing Number	Dimensions in Inches				Capacities ①						Weight in Pounds	
	Bore	Outside Diameter	Land Dia. L <sub>1</sub>	Land Dia. L <sub>2</sub>	Radial in Pounds		Thrust in Pounds		Moment (Lbs-In)			
					Static②	Dyn.	Static②	Dyn.	Static②	Dyn.		
• KC040XP0	4.000	4.750	4.277	4.473	2,100	880	5,260	2,210	4,600	1,930	.45	
KC042XP0	4.250	5.000	4.527	4.723	2,220	920	5,560	2,290	5,140	2,120	.47	
• KC045XP0	4.500	5.250	4.777	4.973	2,340	950	5,860	2,380	5,710	2,320	.48	
• KC047XP0	4.750	5.500	5.027	5.223	2,460	980	6,160	2,460	6,320	2,520	.50	
• KC050XP0	5.000	5.750	5.277	5.473	2,590	1,010	6,460	2,540	6,950	2,730	.58	
• KC055XP0	5.500	6.250	5.777	5.973	2,830	1,080	7,060	2,690	8,300	3,160	.59	
• KC060XP0	6.000	6.750	6.277	6.473	3,070	1,140	7,660	2,840	9,770	3,620	.63	
• KC065XP0	6.500	7.250	6.777	6.973	3,310	1,200	8,270	2,990	11,370	4,110	.68	
• KC070XP0	7.000	7.750	7.277	7.473	3,550	1,250	8,870	3,130	13,080	4,620	.73	
KC075XP0	7.500	8.250	7.777	7.973	3,790	1,310	9,470	3,270	14,910	5,150	.78	
• KC080XP0	8.000	8.750	8.277	8.473	4,030	1,360	10,070	3,410	16,870	5,710	.84	
• KC090XP0	9.000	9.750	9.277	9.473	4,510	1,470	11,270	3,670	21,130	6,890	.94	
• KC100XP0	10.000	10.750	10.277	10.473	4,990	1,570	12,470	3,930	25,880	8,160	1.06	
• KC110XP0	11.000	11.750	11.277	11.473	5,470	1,670	13,680	4,180	31,110	9,510	1.16	
• KC120XP0	12.000	12.750	12.277	12.473	5,950	1,770	14,880	4,420	36,830	10,940	1.25	
KC140XP0	14.000	14.750	14.277	14.473	6,910	1,950	17,280	4,890	49,690	14,050	1.52	
KC160XP0	16.000	16.750	16.277	16.473	7,880	2,130	19,690	5,330	64,480	17,450	1.73	
KC180XP0	18.000	18.750	18.277	18.473	8,840	2,300	22,090	5,760	81,190	21,150	1.94	
KC200XP0	20.000	20.750	20.277	20.473	9,800	2,470	24,500	6,170	99,830	25,120	2.16	
KC250XP0	25.000	25.750	25.277	25.473	12,200	2,850	30,510	7,140	154,800	36,220	2.69	
KC300XP0	30.000	30.750	30.277	30.473	14,610	3,220	36,520	8,050	221,900	48,880	3.21	



③ F = .040  
Bearing corners are normally chamfered

<b>KD SERIES</b>												Snapover separator 1/4" balls
Kaydon Bearing Number	Dimensions in Inches				Capacities ①						Weight in Pounds	
	Bore	Outside Diameter	Land Dia. L <sub>1</sub>	Land Dia. L <sub>2</sub>	Radial in Pounds		Thrust in Pounds		Moment (Lbs-In)			
					Static②	Dyn.	Static②	Dyn.	Static②	Dyn.		
• KD040XP0	4.000	5.000	4.370	4.630	3,080	1,410	7,700	3,520	6,930	3,170	.78	
• KD042XP0	4.250	5.250	4.620	4.880	3,190	1,440	7,980	3,600	7,580	3,420	.83	
• KD045XP0	4.500	5.500	4.870	5.130	3,420	1,510	8,550	3,770	8,550	3,770	.88	
KD047XP0	4.750	5.750	5.120	5.380	3,530	1,540	8,840	3,860	9,280	4,050	.94	
• KD050XP0	5.000	6.000	5.370	5.630	3,760	1,610	9,410	4,020	10,350	4,420	1.00	
• KD055XP0	5.500	6.500	5.870	6.130	4,100	1,700	10,260	4,260	12,310	5,110	1.06	
KD060XP0	6.000	7.000	6.370	6.630	4,450	1,800	11,120	4,490	14,450	5,840	1.16	
• KD065XP0	6.500	7.500	6.870	7.130	4,790	1,890	11,970	4,720	16,760	6,610	1.22	
KD070XP0	7.000	8.000	7.370	7.630	5,130	1,980	12,830	4,940	19,240	7,420	1.31	
KD075XP0	7.500	8.500	7.870	8.130	5,470	2,060	13,680	5,160	21,890	8,260	1.41	
• KD080XP0	8.000	9.000	8.370	8.630	5,810	2,150	14,540	5,370	24,710	9,140	1.53	
• KD090XP0	9.000	10.000	9.370	9.630	6,500	2,320	16,250	5,790	30,870	11,000	1.72	
• KD100XP0	10.000	11.000	10.370	10.630	7,180	2,470	17,960	6,190	37,710	12,990	1.88	
• KD110XP0	11.000	12.000	11.370	11.630	7,870	2,630	19,670	6,570	45,230	15,120	2.06	
• KD120XP0	12.000	13.000	12.370	12.630	8,550	2,780	21,380	6,950	53,440	17,370	2.25	
• KD140XP0	14.000	15.000	14.370	14.630	9,920	3,070	24,800	7,670	71,910	22,250	2.73	
KD160XP0	16.000	17.000	16.370	16.630	11,290	3,350	28,220	8,360	93,110	27,600	3.10	
• KD180XP0	18.000	19.000	18.370	18.630	12,650	3,610	31,640	9,030	117,000	33,400	3.48	
KD200XP0	20.000	21.000	20.370	20.630	14,020	3,870	35,060	9,670	143,700	39,630	3.85	
KD210XP0	21.000	22.000	21.370	21.630	14,710	3,990	36,770	9,980	158,100	42,900	4.04	
• KD250XP0	25.000	26.000	25.370	25.630	17,440	4,470	43,610	11,180	222,400	57,010	4.79	
KD300XP0	30.000	31.000	30.370	30.630	20,860	5,040	52,160	12,600	318,100	76,840	5.73	



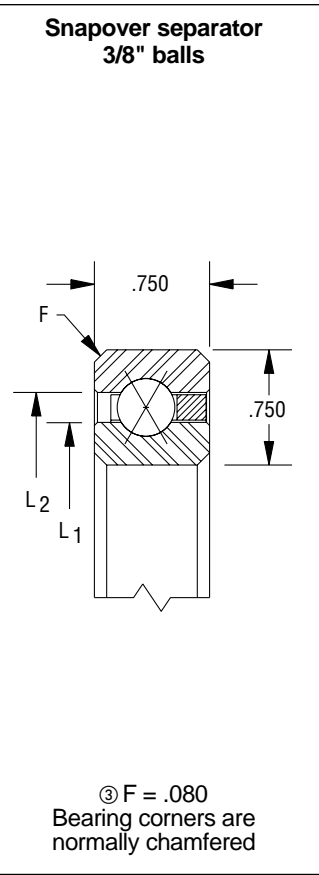
③ F = .060  
Bearing corners are normally chamfered

① Capacities listed are not simultaneous. For combined loading see discussion of Bearing Selection and Load Analysis. Dynamic capacities are based upon 1 million revolutions of L10 life. Published capacities do not apply to hybrid series bearings P, X, and Y - contact Kaydon product engineering for values.  
 ② Static capacities are non-brinell limits based on rigid support from the shaft and housing.  
 ③ "F" is the maximum shaft or housing fillet radius the bearing corners will clear.  
 • Available from stock. All other - contact Kaydon for lead time.

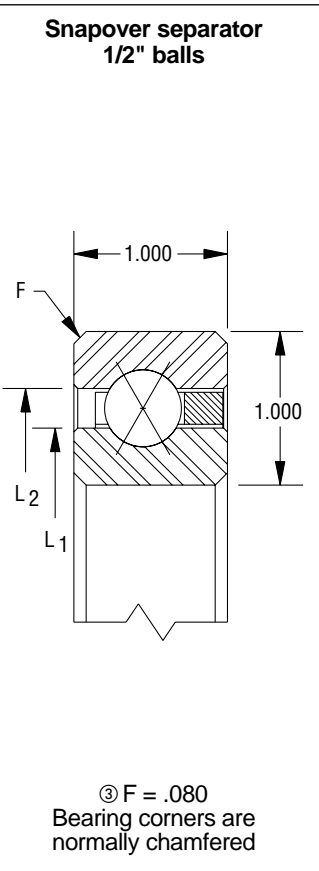
**TYPE X - OPEN BEARINGS**

Section 2-Selection Tables

<b>KF SERIES</b>											
Kaydon Bearing Number	Dimensions in Inches				Capacities <sup>①</sup>						Weight in Pounds
	Bore	Outside Diameter	Land Dia. L <sub>1</sub>	Land Dia. L <sub>2</sub>	Radial in Pounds		Thrust in Pounds		Moment (Lbs-In)		
					Static <sup>②</sup>	Dyn.	Static <sup>②</sup>	Dyn.	Static <sup>②</sup>	Dyn.	
• KF040XP0	4.000	5.500	4.555	4.945	5,360	2,730	13,400	6,830	12,730	6,490	1.9
• KF042XP0	4.250	5.750	4.805	5.195	5,640	2,830	14,110	7,070	14,110	7,070	2.0
• KF045XP0	4.500	6.000	5.055	5.445	5,930	2,920	14,810	7,300	15,550	7,660	2.1
• KF047XP0	4.750	6.250	5.305	5.695	6,210	3,010	15,520	7,530	17,070	8,280	2.2
• KF050XP0	5.000	6.500	5.555	5.945	6,490	3,100	16,220	7,760	18,660	8,920	2.3
• KF055XP0	5.500	7.000	6.055	6.445	7,050	3,280	17,630	8,200	22,040	10,250	2.5
• KF060XP0	6.000	7.500	6.555	6.945	7,620	3,450	19,050	8,630	25,710	11,650	2.7
• KF065XP0	6.500	8.000	7.055	7.445	8,180	3,620	20,460	9,050	29,660	13,130	2.9
• KF070XP0	7.000	8.500	7.555	7.945	8,750	3,790	21,870	9,460	33,890	14,670	3.2
• KF075XP0	7.500	9.000	8.055	8.445	9,310	3,950	23,280	9,870	38,410	16,280	3.4
• KF080XP0	8.000	9.500	8.555	8.945	9,880	4,100	24,690	10,260	43,200	17,960	3.5
• KF090XP0	9.000	10.500	9.555	9.945	11,000	4,410	27,510	11,030	53,640	21,510	3.9
• KF100XP0	10.000	11.500	10.555	10.945	12,130	4,710	30,330	11,770	65,210	25,310	4.3
• KF110XP0	11.000	12.500	11.555	11.945	13,260	5,000	33,150	12,490	77,910	29,350	4.8
• KF120XP0	12.000	13.500	12.555	12.945	14,390	5,280	35,970	13,190	91,730	33,630	5.2
• KF140XP0	14.000	15.500	14.555	14.945	16,650	5,810	41,620	14,530	122,800	42,880	6.0
• KF160XP0	16.000	17.500	16.555	16.945	18,900	6,330	47,260	15,820	158,300	53,000	7.1
• KF180XP0	18.000	19.500	18.555	18.945	21,160	6,820	52,900	17,060	198,400	63,960	7.9
• KF200XP0	20.000	21.500	20.555	20.945	23,420	7,300	58,550	18,250	243,000	75,730	8.9
• KF250XP0	25.000	26.500	25.555	25.945	29,060	8,430	72,650	21,070	374,200	108,500	10.9
• KF300XP0	30.000	31.500	30.555	30.945	34,700	9,490	86,760	23,720	533,600	145,900	13.0
• KF350XP0	35.000	36.500	35.555	35.945	40,350	10,490	100,900	26,220	721,200	187,500	15.1
• KF400XP0	40.000	41.500	40.555	40.945	45,990	11,450	115,000	28,620	937,100	233,200	17.2



<b>KG SERIES</b>											
Kaydon Bearing Number	Dimensions in Inches				Capacities <sup>①</sup>						Weight in Pounds
	Bore	Outside Diameter	Land Dia. L <sub>1</sub>	Land Dia. L <sub>2</sub>	Radial in Pounds		Thrust in Pounds		Moment (Lbs-In)		
					Static <sup>②</sup>	Dyn.	Static <sup>②</sup>	Dyn.	Static <sup>②</sup>	Dyn.	
KG040XP0	4.000	6.000	4.742	5.258	8,210	4,500	20,520	11,260	20,520	11,260	3.6
KG042XP0	4.250	6.250	4.992	5.508	8,210	4,500	20,520	11,260	21,550	11,820	3.8
KG045XP0	4.500	6.500	5.242	5.758	8,760	4,700	21,890	11,750	24,080	12,920	4.0
KG047XP0	4.750	6.750	5.492	6.008	9,300	4,890	23,260	12,230	26,740	14,070	4.1
• KG050XP0	5.000	7.000	5.742	6.258	9,850	5,080	24,620	12,710	29,550	15,250	4.3
• KG055XP0	5.500	7.500	6.242	6.758	10,400	5,270	25,990	13,180	33,790	17,130	4.7
• KG060XP0	6.000	8.000	6.742	7.258	11,490	5,630	28,730	14,090	40,220	19,720	5.1
• KG065XP0	6.500	8.500	7.242	7.758	12,040	5,810	30,100	14,530	45,140	21,790	5.4
• KG070XP0	7.000	9.000	7.742	8.258	13,130	6,160	32,830	15,400	52,530	24,630	5.8
• KG075XP0	7.500	9.500	8.242	8.758	13,680	6,330	34,200	15,820	58,140	26,900	6.1
• KG080XP0	8.000	10.000	8.742	9.258	14,770	6,660	36,940	16,650	66,480	29,980	6.5
• KG090XP0	9.000	11.000	9.742	10.258	16,420	7,150	41,040	17,870	82,080	35,730	7.2
• KG100XP0	10.000	12.000	10.742	11.258	18,060	7,620	45,140	19,040	99,320	41,880	7.9
• KG110XP0	11.000	13.000	11.742	12.258	19,700	8,070	49,250	20,180	118,200	48,420	8.6
• KG120XP0	12.000	14.000	12.742	13.258	21,340	8,510	53,350	21,280	138,700	55,330	9.3
• KG140XP0	14.000	16.000	14.742	15.258	24,620	9,360	61,560	23,410	184,700	70,230	10.8
• KG160XP0	16.000	18.000	16.742	17.258	27,910	10,180	69,770	25,450	237,200	86,530	12.3
• KG180XP0	18.000	20.000	18.742	19.258	31,190	10,960	77,980	27,410	296,300	104,100	13.7
• KG200XP0	20.000	22.000	20.742	21.258	34,470	11,720	86,180	29,300	362,000	123,100	15.8
• KG220XP0	22.000	24.000	22.742	23.258	37,760	12,450	94,390	31,130	434,200	143,200	17.3
• KG250XP0	25.000	27.000	25.742	26.258	42,680	13,510	106,700	33,780	554,900	175,700	19.5
• KG300XP0	30.000	32.000	30.742	31.258	50,890	15,190	127,200	37,980	788,800	235,500	23.3
• KG350XP0	35.000	37.000	35.742	36.258	59,100	16,790	147,700	41,970	1,064,000	302,200	27.1
• KG400XP0	40.000	42.000	40.742	41.258	67,310	18,310	168,300	45,770	1,380,000	375,300	30.8



① Capacities listed are not simultaneous. For combined loading see discussion of Bearing Selection and Load Analysis. Dynamic capacities are based upon 1 million revolutions of L10 life. Published capacities do not apply to hybrid series bearings P, X, and Y - contact Kaydon product engineering for values.

② Static capacities are non-brinell limits based on rigid support from the shaft and housing.

③ "F" is the maximum shaft or housing fillet radius the bearing corners will clear.

• Available from stock. All other - contact Kaydon for lead time.

# Sealed Bearings Selections

## Seals and Shields Available

To realize the full benefits from anti-friction bearings, it is important to keep them clean and well lubricated. Seals and shields properly designed and mounted help to accomplish this. In this catalog these terms have the following definitions:

**Seal**—a contacting closure between the stationary and rotating members, for retaining lubricant within and excluding foreign material from the bearing. Seals are retained in the outer race and make positive contact with the inner race.

**Shield**—a closure for the same purpose as a seal but without positive contact.

A seal is more effective, but requires more turning effort (torque), generates more heat, and as a result, has a lower speed limit than an open or shielded bearing.

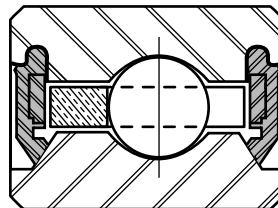
The accompanying illustrations are examples by which Reali-Slim® bearings may be sealed or shielded, either integrally or externally. The lubricant and lubrication systems, torque requirements, speed, and operating environment will influence the choice.

Integral seals and shields offer a very compact overall design with the additional advantage of protecting the bearing before, during and after installation.

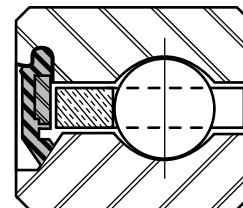
Figure 9 shows a double sealed Reali-Slim® bearing, available from stock in the JU series. In this case, adding shields and seals requires an increase in the width of the bearing. Page 12, Position 2. In the case of JA, JB, and JG double sealed Reali-Slims, the bearing width is the same as that of the open bearing.

Illustrated in Figure 10 is a double Lami-Seal® bearing. Shown in Figure 11 is a double Lami-Shield® bearing for use where a shield will suffice or is required due to torque limitations or speed.

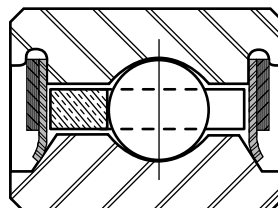
**Note:** Sealed Reali-Slim® bearings are pre-lubricated with a general purpose grease. Operating conditions (i.e. time, temperature, speed, environment) may result in premature grease breakdown. Grease options are available upon request.



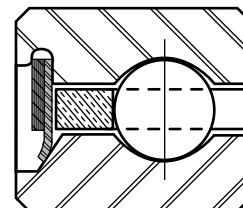
**Figure 9**  
Double Sealed Reali-Slim®



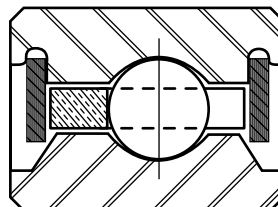
**Figure 12**  
Single Sealed Reali-Slim®



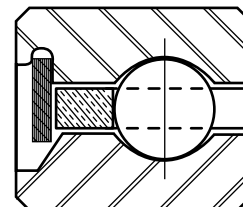
**Figure 10**  
Double Lami-Seal® bearing



**Figure 13**  
Single Lami-Seal® bearing



**Figure 11**  
Double Lami-Shield® bearing



**Figure 14**  
Single Lami-Shield® bearing

**Note:** Pictures are for illustration only and are not intended for design specification.

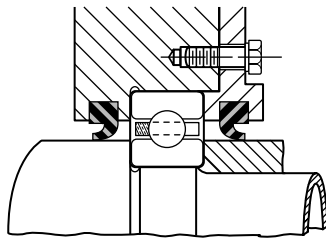
Where weight and space are at a premium, and a seal or shield is required on one side only, single sealed or single shielded bearings as shown in Figures 12, 13 and 14 may be supplied.

Figure 15 shows a Buna N lip-type seal ring available in a variety of cross-sections compatible with the Reali-Slim® bearing series. While this is a very effective seal, torque is substantial and speeds must not exceed 1000 feet per minute if continuous. Figure 16 shows a felt seal ring which is suitable for higher speeds and can be made from commercially available strip stock by bonding the ends with solvent resistant glue. Many grades of felt are readily obtainable for experimental determination of the best compromise between torque, heat, wear, and seal effectiveness.

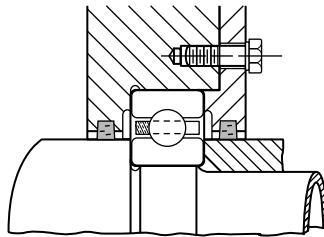
If grease lubrication is used and torque is not critical, a very effective shield is that shown in Figure 17 where annular grooves are cut in the housing shoulder and clamp plate and filled with grease.

When a separate shield is required, washers made from precision flat stock are ideal, as shown in Figure 18. They serve well where weight limitations are strict.

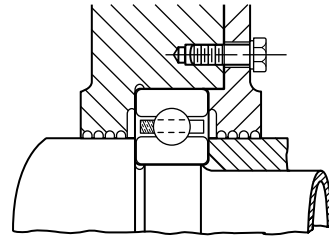
Whether or not integral seals or shields are specified, bearings must be isolated from hostile environments and debris.



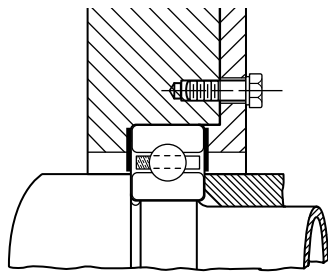
**Figure 15**  
Buna N Lip-Type Seal



**Figure 16**  
Felt Seal Ring



**Figure 17**  
Annular Grooves



**Figure 18**  
Washer Shield From  
Precision Flat Stock

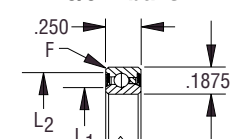
# Sealed Bearing Selections

## Type C

### Radial Contact

<b>JHA SERIES (DOUBLE SEALED)</b>									
Kaydon Bearing Number	Dimensions in Inches				Radial Capacity (lbs.) <sup>①</sup>		Limiting Speeds (RPM*)	Torque Max. No Load (Oz-In) <sup>④</sup>	Weight in Pounds
	Bore	Outside Diameter	Dia. L <sub>1</sub>	Dia. L <sub>2</sub>	Static <sup>②</sup>	Dyn.			
JHA10CL0	1.000	1.375	1.108	1.274	290	150	6110	5	.035
JHA15CL0	1.500	1.875	1.608	1.774	400	180	4300	5	.052
JHA17CL0	1.750	2.125	1.858	2.024	460	200	3750	6	.060

Snapover separator  
3/32" balls



③ F = .015  
Bearing corners are normally chamfered

<b>JA SERIES (DOUBLE SEALED)</b>									
Kaydon Bearing Number	Dimensions in Inches				Radial Capacity (lbs.) <sup>①</sup>		Limiting Speeds (RPM*)	Torque Max. No Load (Oz-In) <sup>④</sup>	Weight in Pounds
	Bore	Outside Diameter	Dia. L <sub>1</sub>	Dia. L <sub>2</sub>	Static <sup>②</sup>	Dyn.			
• JA020CP0	2.000	2.500	2.148	2.356	680	320	3,220	6	.10
• JA025CP0	2.500	3.000	2.648	2.856	830	360	2,630	8	.12
• JA030CP0	3.000	3.500	3.148	3.356	990	410	2,230	12	.14
• JA035CP0	3.500	4.000	3.648	3.856	1,140	450	1,930	16	.17
• JA040CP0	4.000	4.500	4.148	4.356	1,290	480	1,700	20	.19
• JA042CP0	4.250	4.750	4.398	4.606	1,370	500	1,610	24	.20
• JA045CP0	4.500	5.000	4.648	4.856	1,440	520	1,520	28	.21
JA047CP0	4.750	5.250	4.898	5.106	1,520	540	1,450	32	.22
JA050CP0	5.000	5.500	5.148	5.356	1,590	560	1,380	36	.23
JA055CP0	5.500	6.000	5.648	5.856	1,750	590	1,260	44	.25
JA060CP0	6.000	6.500	6.148	6.356	1,900	630	1,160	52	.28
JA065CP0	6.500	7.000	6.648	6.856	2,050	660	1,070	61	.30

Snapover separator  
1/8" balls



③ F = .025  
Bearing corners are normally chamfered

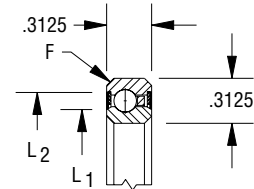
- ① Capacities listed are not simultaneous. For combined loading see discussion of Bearing Selection and Load Analysis. Dynamic capacities are based upon 1 million revolutions of L10 life. Published capacities do not apply to hybrid series bearings P, X, and Y - contact Kaydon product engineering for values.
- ② Static capacities are non-brinell limits based on rigid support from the shaft and housing.
- ③ "F" is the maximum shaft or housing fillet radius the bearing corners will clear.
- ④ Torque figures shown are for single bearings with standard lubricant at room temperature and under 5 pounds thrust load.
  - \* Values apply to bearings loaded up to 20% of their dynamic capacity.
  - Available from stock. All other – contact Kaydon for lead time.

**TYPE C - SEALED BEARINGS**

Section 2-Selection Tables

<b>JB SERIES (DOUBLE SEALED)</b>									
Kaydon Bearing Number	Dimensions in Inches				Radial Capacity (lbs.) <sup>①</sup>		Limiting Speeds (RPM*)	Torque Max. No Load (Oz-In) <sup>④</sup>	Weight in Pounds <sup>⑤</sup>
	Bore	Outside Diameter	Dia. L <sub>1</sub>	Dia. L <sub>2</sub>	Static <sup>②</sup>	Dyn.			
• JB020CP0	2.000	2.625	2.136	2.362	930	450	3,130	6	.15
• JB025CP0	2.500	3.125	2.636	2.862	1,140	520	2,580	8	.19
• JB030CP0	3.000	3.625	3.136	3.362	1,340	580	2,190	12	.22
• JB035CP0	3.500	4.125	3.636	3.862	1,540	630	1,900	16	.27
• JB040CP0	4.000	4.625	4.136	4.362	1,750	690	1,630	20	.30
• JB042CP0	4.250	4.875	4.386	4.662	1,830	710	1,600	24	.31
• JB045CP0	4.500	5.125	4.636	4.862	1,950	740	1,500	28	.34
• JB047CP0	4.750	5.375	4.886	5.162	2,030	760	1,430	32	.35
• JB050CP0	5.000	5.625	5.136	5.362	2,150	790	1,360	36	.37
• JB055CP0	5.500	6.125	5.636	5.862	2,360	840	1,240	44	.40
• JB060CP0	6.000	6.625	6.136	6.362	2,560	890	1,150	52	.44
• JB065CP0	6.500	7.125	6.636	6.862	2,760	930	1,060	61	.47

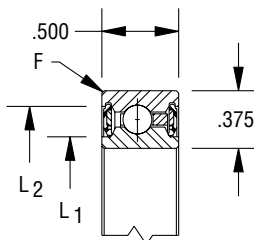
Snapover separator  
5/32" balls



③ F = .040  
Bearing corners are normally chamfered

<b>JU SERIES (DOUBLE SEALED)</b>									
Kaydon Bearing Number	Dimensions in Inches				Radial Capacity (lbs.) <sup>①</sup>		Limiting Speeds (RPM*)	Torque Max. No Load (Lbs-In) <sup>④</sup>	Weight in Pounds <sup>⑤</sup>
	Bore	Outside Diameter	Dia. L <sub>1</sub>	Dia. L <sub>2</sub>	Static <sup>②</sup>	Dyn.			
• JU040CP0	4.000	4.750	4.150	4.547	2,100	880	1,640	2.9	.55
• JU042CP0	4.250	5.000	4.400	4.797	2,220	920	1,520	3.2	.58
• JU045CP0	4.500	5.250	4.650	5.047	2,340	950	1,440	3.5	.61
• JU047CP0	4.750	5.500	4.900	5.295	2,460	980	1,360	3.9	.65
• JU050CP0	5.000	5.750	5.150	5.545	2,590	1,010	1,300	4.3	.68
• JU055CP0	5.500	6.250	5.650	6.042	2,830	1,080	1,180	5.1	.74
• JU060CP0	6.000	6.750	6.150	6.542	3,070	1,140	1,080	6.1	.81
• JU065CP0	6.500	7.250	6.650	7.037	3,315	1,200	1,000	7.0	.87
• JU070CP0	7.000	7.750	7.150	7.537	3,550	1,250	920	8.1	.93
• JU075CP0	7.500	8.250	7.650	8.037	3,790	1,310	860	9.2	.99
• JU080CP0	8.000	8.750	8.150	8.537	4,030	1,360	810	10.4	1.06
• JU090CP0	9.000	9.750	9.150	9.535	4,510	1,470	720	13.0	1.18
• JU100CP0	10.000	10.750	10.150	10.535	4,990	1,570	650	16.0	1.31
• JU110CP0	11.000	11.750	11.150	11.535	5,470	1,670	590	19.2	1.43
• JU120CP0	12.000	12.750	12.150	12.535	5,950	1,770	540	22.8	1.56

Snapover separator  
3/16" balls



③ F = .015  
Bearing corners are normally chamfered

- ① Capacities listed are not simultaneous. For combined loading see discussion of Bearing Selection and Load Analysis. Dynamic capacities are based upon 1 million revolutions of L10 life. Published capacities do not apply to hybrid series bearings P, X, and Y - contact Kaydon product engineering for values.
- ② Static capacities are non-brinell limits based on rigid support from the shaft and housing.
- ③ "F" is the maximum shaft or housing fillet radius the bearing corners will clear.
- ④ Torque figures shown are for single bearings with standard lubricant at room temperature and under 5 pound thrust load.
- ⑤ Weight includes standard lubricant.
- \* Values apply to bearings loaded up to 20% of their dynamic capacity.
- Available from stock. All other - contact Kaydon for lead time.

**TYPE C - SEALED BEARINGS**

<b>JG SERIES (DOUBLE SEALED)</b>										
Kaydon Bearing Number	Dimensions in Inches				Radial Capacity (lbs.) <sup>①</sup>		Limiting Speeds (RPM*)	Torque Max. No Load (lb-in) <sup>④</sup>	Weight in Pounds	<p>Snapover separator 1/2" balls</p> <p>③ F = .080 Bearing corners are normally chamfered</p>
	Bore	Outside Diameter	Dia. L <sub>1</sub>	Dia. L <sub>2</sub>	Static <sup>②</sup>	Dyn.				
<b>JG120CP0</b>	<b>12.000</b>	14.000	12.554	13.602	21,340	8,510	140	44	9.3	
<b>JG140CP0</b>	<b>14.000</b>	16.000	14.554	15.602	24,620	9,360	125	59	10.8	
<b>JG160CP0</b>	<b>16.000</b>	18.000	16.554	17.602	27,910	10,180	110	76	12.3	
<b>JG180CP0</b>	<b>18.000</b>	20.000	18.554	19.602	31,190	10,960	100	95	13.7	
<b>JG200CP0</b>	<b>20.000</b>	22.000	20.554	21.602	34,470	11,720	90	115	15.8	
<b>JG250CP0</b>	<b>25.000</b>	27.000	25.554	26.602	42,680	13,510	75	177	19.5	
<b>JG300CP0</b>	<b>30.000</b>	32.000	30.554	31.602	50,890	15,190	60	252	23.3	
<b>JG350CP0</b>	<b>35.000</b>	37.000	35.554	36.602	59,100	16,790	55	339	27.1	
<b>JG400CP0</b>	<b>40.000</b>	42.000	40.554	41.602	67,310	18,310	50	440	30.8	

- ① Capacities listed are not simultaneous. For combined loading see discussion of Bearing Selection and Load Analysis. Dynamic capacities are based upon 1 million revolutions of L10 life. Published capacities do not apply to hybrid series bearings P, X, and Y - contact Kaydon product engineering for values.
- ② Static capacities are non-brinell limits based on rigid support from the shaft and housing.
- ③ "F" is the maximum shaft or housing fillet radius the bearing corners will clear.
- ④ Torque figures shown are for single bearings with standard lubricant at room temperature and under 5 pounds thrust load.
- \* Values apply to bearings loaded up to 20% of their dynamic capacity.  
Contact Kaydon for lead time.

**CONTACT KAYDON AT—**

Kaydon Corporation • Muskegon, Michigan 49443  
 Telephone: 231/755-3741 • Fax: 231/759-4102

**NEED SERVICE FAST?**

**1-800-514-3066**

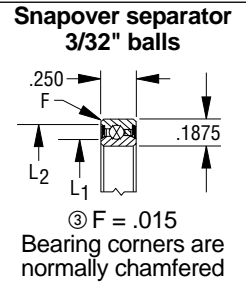
Website: [www.reali-slim.com](http://www.reali-slim.com)

# Sealed Bearing Selections

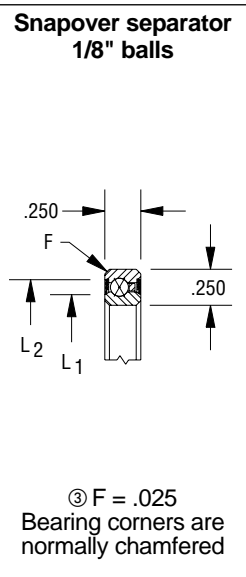
## Type X

### Four-Point Contact

<b>JHA SERIES (DOUBLE SEALED)</b>													
Kaydon Bearing Number	Dimensions in Inches				Capacities <sup>①</sup>						Limiting Speeds (RPM*)	Torque Max. No Load (Oz-In) <sup>④</sup>	Weight in Pounds
	Bore	Outside Diameter	Dia. L <sub>1</sub>	Dia. L <sub>2</sub>	Radial in Lbs.		Thrust in Lbs.		Moment (Lbs.-In)				
					Static <sup>②</sup>	Dyn.	Static <sup>②</sup>	Dyn.	Static <sup>②</sup>	Dyn.			
JHA10XL0	1.000	1.375	1.108	1.274	290	150	730	370	170	90	3,000	5	.035
JHA15XL0	1.500	1.875	1.608	1.774	400	180	1,000	460	340	150	2,000	5	.052
JHA17XL0	1.750	2.125	1.858	2.024	460	200	1,140	500	440	190	1,710	6	.060



<b>JA SERIES (DOUBLE SEALED)</b>													
Kaydon Bearing Number	Dimensions in Inches				Capacities <sup>①</sup>						Limiting Speeds (RPM*)	Torque Max. No Load (Oz-In) <sup>④</sup>	Weight in Pounds
	Bore	Outside Diameter	Dia. L <sub>1</sub>	Dia. L <sub>2</sub>	Radial in Lbs.		Thrust in Lbs.		Moment (Lbs.-In)				
					Static <sup>②</sup>	Dyn.	Static <sup>②</sup>	Dyn.	Static <sup>②</sup>	Dyn.			
•JA020XP0	2.000	2.500	2.148	2.356	680	320	1,710	790	770	360	1,500	6	.10
•JA025XP0	2.500	3.000	2.648	2.856	830	360	2,090	910	1,150	500	1,200	8	.12
•JA030XP0	3.000	3.500	3.148	3.356	990	410	2,470	1,010	1,600	660	830	12	.14
•JA035XP0	3.500	4.000	3.648	3.856	1,140	450	2,850	1,110	2,130	840	710	16	.17
•JA040XP0	4.000	4.500	4.148	4.356	1,290	480	3,220	1,210	2,740	1,030	620	20	.19
•JA042XP0	4.250	4.750	4.398	4.606	1,370	500	3,410	1,260	3,070	1,130	580	24	.20
•JA045XP0	4.500	5.000	4.648	4.856	1,440	520	3,600	1,310	3,420	1,240	550	28	.21
JA047XP0	4.750	5.250	4.898	5.106	1,520	540	3,790	1,350	3,790	1,350	520	32	.22
JA050XP0	5.000	5.500	5.148	5.356	1,590	560	3,980	1,400	4,180	1,460	500	36	.23
JA055XP0	5.500	6.000	5.648	5.856	1,750	590	4,360	1,480	5,020	1,700	450	44	.25
JA060XP0	6.000	6.500	6.148	6.356	1,900	630	4,740	1,570	5,930	1,960	330	52	.28
JA065XP0	6.500	7.000	6.648	6.856	2,050	660	5,120	1,650	6,910	2,230	300	61	.30

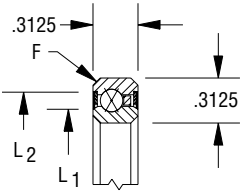


- ① Capacities listed are not simultaneous. For combined loading see discussion of Bearing Selection and Load Analysis. Dynamic capacities are based upon 1 million revolutions of L10 life. Published capacities do not apply to hybrid series bearings P, X, and Y - contact Kaydon product engineering for values.
- ② Static capacities are non-brinell limits based on rigid support from the shaft and housing.
- ③ "F" is the maximum shaft or housing fillet radius the bearing corners will clear.
- ④ Torque figures shown are for single bearings with standard lubricant at room temperature and under 5 pounds thrust load.
- \* Values apply to bearings loaded up to 20% of their dynamic capacity.
- Available from stock. All other - contact Kaydon for lead time.



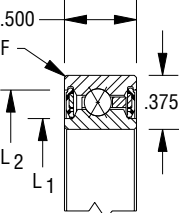
**TYPE X - SEALED BEARINGS**

<b>JB SERIES (DOUBLE SEALED)</b>													Snapover separator 5/32" balls	
Kaydon Bearing Number	Dimensions in Inches				Capacities <sup>①</sup>						Limiting Speeds (RPM*)	Torque Max. No Load (In-Oz) <sup>⑤</sup>	Weight in Pounds	
	Bore	Outside Diameter	Dia. L <sub>1</sub>	Dia. L <sub>2</sub>	Radial in Lbs.		Thrust in Lbs.		Moment (Lbs.-In)					
					Static <sup>②</sup>	Dyn.	Static <sup>②</sup>	Dyn.	Static <sup>②</sup>	Dyn.				
•JB020XP0	2.000	2.625	2.136	2.362	930	450	2,340	1,130	1,080	520	1,500	6	.15	
•JB025XP0	2.500	3.125	2.636	2.862	1,140	520	2,840	1,290	1,600	730	1,200	8	.19	
•JB030XP0	3.000	3.625	3.136	3.362	1,340	580	3,350	1,440	2,220	960	1,000	12	.22	
•JB035XP0	3.500	4.125	3.636	3.862	1,540	630	3,860	1,590	2,940	1,210	710	16	.27	
•JB040XP0	4.000	4.625	4.136	4.362	1,750	690	4,370	1,720	3,770	1,490	620	20	.30	
•JB042XP0	4.250	4.875	4.386	4.662	1,830	710	4,570	1,780	4,170	1,620	590	24	.31	
•JB045XP0	4.500	5.125	4.636	4.862	1,950	740	4,880	1,850	4,690	1,780	550	28	.34	
•JB047XP0	4.750	5.375	4.886	5.162	2,030	760	5,080	1,900	5,140	1,930	520	32	.35	
•JB050XP0	5.000	5.625	5.136	5.362	2,150	790	5,380	1,980	5,720	2,100	500	36	.37	
•JB055XP0	5.500	6.125	5.636	5.862	2,360	840	5,890	2,100	6,850	2,440	450	44	.40	
•JB060XP0	6.000	6.625	6.136	6.362	2,560	890	6,400	2,220	8,080	2,800	410	52	.44	
•JB065XP0	6.500	7.125	6.636	6.862	2,760	930	6,910	2,340	9,410	3,180	380	61	.47	



③ F = .040  
Bearing corners are normally chamfered

<b>JU SERIES (DOUBLE SEALED)</b>													Snapover separator 3/16" balls	
Kaydon Bearing Number	Dimensions in Inches				Capacities <sup>①</sup>						Limiting Speeds (RPM*)	④ Lube Amt. (c.c.)	⑤ Torque Max. No Load (Lbs-In)	⑥ Weight in Pounds
	Bore	Outside Dia.	Dia. L <sub>1</sub>	Dia. L <sub>2</sub>	Radial in Lbs.		Thrust in Lbs.		Moment (Lbs.-In)					
					Static <sup>②</sup>	Dyn.	Static <sup>②</sup>	Dyn.	Static <sup>②</sup>	Dyn.				
•JU040XP0	4.000	4.750	4.150	4.547	2,100	880	5,260	2,210	4,600	1,930	620	2.5	2.9	.55
•JU042XP0	4.250	5.000	4.400	4.797	2,220	920	5,560	2,290	5,140	2,120	590	2.5	3.2	.58
•JU045XP0	4.500	5.250	4.650	5.047	2,340	950	5,860	2,380	5,710	2,320	550	3.0	3.5	.61
•JU047XP0	4.750	5.500	4.900	5.295	2,460	980	6,160	2,460	6,320	2,520	520	3.0	3.9	.65
•JU050XP0	5.000	5.750	5.150	5.545	2,590	1,010	6,460	2,540	6,950	2,730	500	3.5	4.3	.68
•JU055XP0	5.500	6.250	5.650	6.042	2,830	1,080	7,060	2,690	8,300	3,160	450	3.5	5.1	.74
•JU060XP0	6.000	6.750	6.150	6.542	3,070	1,140	7,660	2,840	9,770	3,620	410	3.5	6.1	.81
•JU065XP0	6.500	7.250	6.650	7.037	3,310	1,200	8,270	2,990	11,370	4,110	380	4.0	7.0	.87
•JU070XP0	7.000	7.750	7.150	7.537	3,550	1,250	8,870	3,130	13,080	4,620	350	4.5	8.1	.93
•JU075XP0	7.500	8.250	7.650	8.037	3,790	1,310	9,470	3,270	14,910	5,150	330	4.5	9.2	.99
•JU080XP0	8.000	8.750	8.150	8.537	4,030	1,360	10,070	3,410	16,870	5,710	310	5.0	10.4	1.06
•JU090XP0	9.000	9.750	9.150	9.535	4,510	1,470	11,270	3,670	21,130	6,890	220	5.5	13.0	1.18
•JU100XP0	10.000	10.750	10.150	10.535	4,990	1,570	12,470	3,930	25,880	8,160	200	6.0	16.0	1.31
•JU110XP0	11.000	11.750	11.150	11.535	5,470	1,670	13,680	4,180	31,110	9,510	180	6.5	19.2	1.43
•JU120XP0	12.000	12.750	12.150	12.535	5,950	1,770	14,880	4,420	36,830	10,940	160	7.0	22.8	1.56



③ F = .015  
Bearing corners are normally chamfered

① Capacities listed are not simultaneous. For combined loading see discussion of Bearing Selection and Load Analysis. Dynamic capacities are based upon 1 million revolutions of L10 life. Published capacities do not apply to hybrid series bearings P, X, and Y - contact Kaydon product engineering for values.

② Static capacities are non-brinell limits based on rigid support from the shaft and housing.

③ "F" is the maximum shaft or housing fillet radius the bearing corners will clear.

④ "JU" Series Bearings are supplied with general purpose grease, satisfactory for operating temperatures of -15°F to +250°F (-26°C to +121°C). Other lubricants are available.

⑤ Torque figures shown are single bearings with standard lubricant at room temperature and under 5 pound thrust load.

⑥ Weight includes standard lubricant.

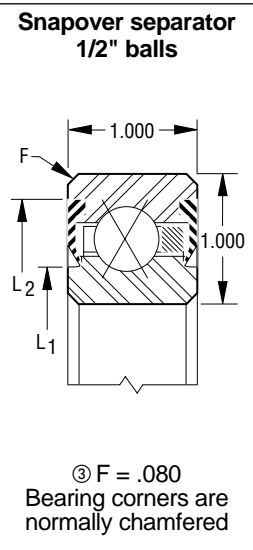
\* Values apply to bearings loaded up to 20% of their dynamic capacity.

• Available from stock. All other - contact Kaydon for lead time.

**TYPE X - SEALED BEARINGS**

Section 2-Selection Tables

<b>JG SERIES (DOUBLE SEALED)</b>													<b>Snapover separator 1/2" balls</b>	
Kaydon Bearing Number	Dimensions in Inches				Capacities <sup>①</sup>						Limiting Speeds (RPM*)	Torque Max. No Load (Lbs-In) <sup>④</sup>	⑤ Weight in Pounds	
	Bore	Outside Diameter	Dia. L <sub>1</sub>	Dia. L <sub>2</sub>	Radial in Lbs.		Thrust in Lbs.		Moment (Lbs.-In)					
					Static <sup>②</sup>	Dyn.	Static <sup>②</sup>	Dyn.	Static <sup>②</sup>	Dyn.				
JG120XP0	12.000	14.000	12.554	13.602	21,340	8,510	53,350	21,280	138,700	55,300	140	44	9.3	
JG140XP0	14.000	16.000	14.554	15.602	24,620	9,360	61,560	34,410	184,700	70,230	125	59	10.8	
JG160XP0	16.000	18.000	16.554	17.602	27,910	10,180	69,770	25,450	237,200	86,530	110	76	12.3	
JG180XP0	18.000	20.000	18.554	19.602	31,190	10,960	77,980	27,410	296,300	104,100	100	95	13.7	
JG200XP0	20.000	22.000	20.554	21.602	34,470	11,720	86,180	29,300	362,000	123,100	90	115	15.8	
JG220XP0	22.000	24.000	22.554	23.602	37,750	12,450	94,390	31,130	434,200	143,190	80	138	16.8	
JG250XP0	25.000	27.000	25.554	26.602	42,680	13,510	106,700	33,780	554,900	175,700	75	177	19.5	
JG300XP0	30.000	32.000	30.554	31.602	50,890	15,190	127,200	37,980	788,800	235,500	60	252	23.3	
JG350XP0	35.000	37.000	35.554	36.602	59,100	16,790	147,700	41,970	1,064,000	302,300	55	339	27.1	
JG400XP0	40.000	42.000	40.554	41.602	63,310	18,310	168,300	45,770	1,380,000	375,300	50	440	30.8	



- ① Capacities listed are not simultaneous. For combined loading see discussion of Bearing Selection and Load Analysis. Dynamic capacities are based upon 1 million revolutions of L10 life. Published capacities do not apply to hybrid series bearings P, X, and Y - contact Kaydon product engineering for values.
- ② Static capacities are non-brinell limits based on rigid support from the shaft and housing.
- ③ "F" is the maximum shaft or housing fillet radius the bearing corners will clear.
- ④ Torque figures shown are single bearings with standard lubricant at room temperature and under 5 pound thrust load.
- ⑤ Weight includes standard lubricant.
- \* Values apply to bearings loaded up to 20% of their dynamic capacity. Contact Kaydon for lead time.

**CONTACT KAYDON AT—**  
 Kaydon Corporation • Muskegon, Michigan 49443  
 Telephone: 231/755-3741 • Fax: 231/759-4102

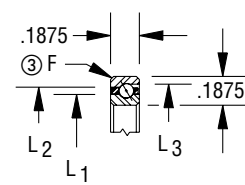
**NEED SERVICE FAST?**  
**1-800-514-3066**  
 Website: [www.real-slim.com](http://www.real-slim.com)

# Stainless Steel Reali-Slim® Bearings

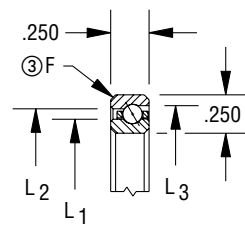
## Type A

### Angular Contact

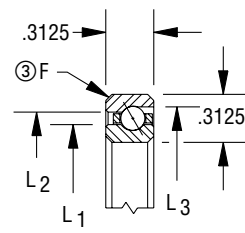
<b>SAA SERIES (3/16" cross-section)</b>										
Kaydon Bearing Number	Dimensions in Inches					Capacities in Pounds ①				Weight in Pounds
	Bore	Outside Diameter	Land Dia. L <sub>1</sub>	Land Dia. L <sub>2</sub>	C'Bore Dia. L <sub>3</sub>	Radial		Thrust		
						Static②	Dyn.	Static②	Dyn.	
• SAA10AG0	1.000	1.375	1.140	1.235	1.274	340	150	970	450	.025
• SAA15AG0	1.500	1.875	1.640	1.735	1.774	480	300	1,380	560	.038



<b>SA SERIES (1/4" cross-section)</b>										
Kaydon Bearing Number	Dimensions in Inches					Capacities in Pounds ①				Weight in Pounds
	Bore	Outside Diameter	Land Dia. L <sub>1</sub>	Land Dia. L <sub>2</sub>	C'Bore Dia. L <sub>3</sub>	Radial		Thrust		
						Static②	Dyn.	Static②	Dyn.	
• SA020AR0	2.000	2.500	2.186	2.314	2.369	790	330	2,280	960	.10
• SA025AR0	2.500	3.000	2.686	2.814	2.869	960	380	2,780	1,100	.12
• SA030AR0	3.000	3.500	3.186	3.314	3.367	1,140	430	3,290	1,230	.14
• SA035AR0	3.500	4.000	3.686	3.814	3.867	1,310	470	3,790	1,350	.17
• SA040AR0	4.000	4.500	4.186	4.314	4.367	1,490	510	4,300	1,470	.19



<b>SB SERIES (5/16" cross-section)</b>										
Kaydon Bearing Number	Dimensions in Inches					Capacities in Pounds ①				Weight in Pounds
	Bore	Outside Diameter	Land Dia. L <sub>1</sub>	Land Dia. L <sub>2</sub>	C'Bore Dia. L <sub>3</sub>	Radial		Thrust		
						Static②	Dyn.	Static②	Dyn.	
• SB020AR0	2.000	2.625	2.231	2.393	2.464	1,090	480	3,150	1,380	.15
• SB025AR0	2.500	3.125	2.731	2.893	2.964	1,340	550	3,860	1,590	.19
• SB030AR0	3.000	3.625	3.231	3.393	3.462	1,550	610	4,470	1,750	.22
• SB035AR0	3.500	4.125	3.731	3.893	3.962	1,790	670	5,180	1,930	.27
• SB040AR0	4.000	4.625	4.231	4.393	4.460	2,040	730	5,890	2,100	.30



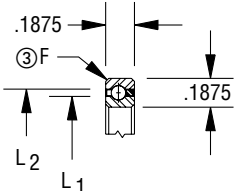
- ① Capacities listed are not simultaneous. For combined loading see discussion of Bearing Selection and Load Analysis. Dynamic capacities are based upon 1 million revolutions of L10 life. Published capacities do not apply to hybrid series bearings P, X, and Y - contact Kaydon product engineering for values.
- ② Static capacities are non-brinell limits based on rigid support from the shaft and housing.
- ③ "F" is the maximum shaft or housing fillet radius the bearing corners will clear.
  - Available from stock. All other – contact Kaydon for lead time.

# Stainless Steel Reali-Slim® Bearings

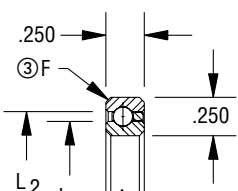
## Type C

### Radial Contact

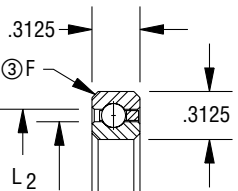
<b>SAA SERIES (3/16" cross section)</b>							
Kaydon Bearing Number	Dimensions in Inches				Radial Capacity (lbs.) ①		Weight in Pounds
	Bore	Outside Diameter	Land Dia. L <sub>1</sub>	Land Dia. L <sub>2</sub>	Static ②	Dynamic	
• SAA10CL0	1.000	1.375	1.140	1.235	290	150	.026
• SAA15CL0	1.500	1.875	1.640	1.735	400	180	.039



<b>SA SERIES (1/4" cross section)</b>							
Kaydon Bearing Number	Dimensions in Inches				Radial Capacity (lbs.) ①		Weight in Pounds
	Bore	Outside Diameter	Land Dia. L <sub>1</sub>	Land Dia. L <sub>2</sub>	Static ②	Dynamic	
• SA020CP0	2.000	2.500	2.186	2.314	680	320	.10
• SA025CP0	2.500	3.000	2.686	2.814	830	360	.13
• SA030CP0	3.000	3.500	3.186	3.314	990	410	.15
• SA035CP0	3.500	4.000	3.686	3.814	1,140	450	.18
• SA040CP0	4.000	4.500	4.186	4.314	1,290	480	.19



<b>SB SERIES (5/16" cross section)</b>							
Kaydon Bearing Number	Dimensions in Inches				Radial Capacity (lbs.) ①		Weight in Pounds
	Bore	Outside Diameter	Land Dia. L <sub>1</sub>	Land Dia. L <sub>2</sub>	Static ②	Dynamic	
• SB020CP0	2.000	2.625	2.231	2.393	930	450	.16
• SB025CP0	2.500	3.125	2.731	2.893	1,140	520	.20
• SB030CP0	3.000	3.625	3.231	3.393	1,340	580	.24
• SB035CP0	3.500	4.125	3.731	3.893	1,540	630	.27
• SB040CP0	4.000	4.625	4.231	4.393	1,750	690	.30



① Capacities listed are not simultaneous. For combined loading see discussion of Bearing Selection and Load Analysis. Dynamic capacities are based upon 1 million revolutions of L10 life. Published capacities do not apply to hybrid series bearings P, X, and Y - contact Kaydon product engineering for values.

② Static capacities are non-brinell limits based on rigid support from the shaft and housing.

③ "F" is the maximum shaft or housing fillet radius the bearing corners will clear.

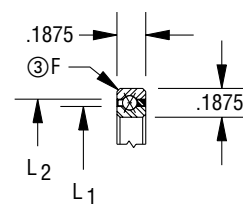
• Available from stock. All other - contact Kaydon for lead time.

# Stainless Steel Reali-Slim® Bearings

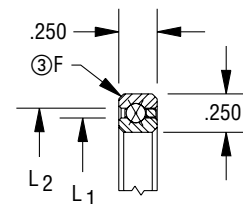
## Type X

### Four-Point Contact

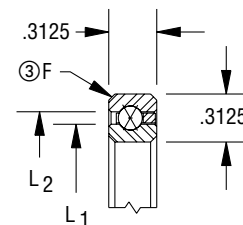
<b>SERIES SAA (3/16" cross section)</b>											
Kaydon Bearing Number	Dimensions in Inches				Capacities <sup>①</sup>						Weight in Pounds
	Bore	Outside Dia.	Land Dia.L <sub>1</sub>	Land Dia.L <sub>2</sub>	Radial in Pounds		Thrust in Pounds		Moment (Lbs-In)		
					Static <sup>②</sup>	Dyn.	Static <sup>②</sup>	Dyn.	Static <sup>②</sup>	Dyn.	
• SAA10XLO	1.000	1.375	1.140	1.235	290	150	730	370	170	90	.026
• SAA15XLO	1.500	1.875	1.640	1.735	400	180	1,000	460	340	150	.039



<b>SERIES SA (1/4" cross section)</b>											
Kaydon Bearing Number	Dimensions in Inches				Capacities <sup>①</sup>						Weight in Pounds
	Bore	Outside Dia.	Land Dia.L <sub>1</sub>	Land Dia.L <sub>2</sub>	Radial in Pounds		Thrust in Pounds		Moment (Lbs-In)		
					Static <sup>②</sup>	Dyn.	Static <sup>②</sup>	Dyn.	Static <sup>②</sup>	Dyn.	
• SA020XP0	2.000	2.500	2.186	2.314	680	320	1,710	790	770	360	.10
• SA025XP0	2.500	3.000	2.686	2.814	830	360	2,090	910	1,150	500	.13
• SA030XP0	3.000	3.500	3.186	3.314	990	410	2,470	1,010	1,600	660	.15
• SA035XP0	3.500	4.000	3.686	3.814	1,140	450	2,850	1,110	2,130	840	.18
• SA040XP0	4.000	4.500	4.186	4.314	1,290	480	3,220	1,210	2,740	1,030	.19



<b>SERIES SB (5/16" cross section)</b>											
Kaydon Bearing Number	Dimensions in Inches				Capacities <sup>①</sup>						Weight in Pounds
	Bore	Outside Dia.	Land Dia.L <sub>1</sub>	Land Dia.L <sub>2</sub>	Radial in Pounds		Thrust in Pounds		Moment (Lbs-In)		
					Static <sup>②</sup>	Dyn.	Static <sup>②</sup>	Dyn.	Static <sup>②</sup>	Dyn.	
• SB020XP0	2.000	2.625	2.231	2.393	930	450	2,340	1,130	1,080	520	.16
• SB025XP0	2.500	3.125	2.731	2.893	1,140	520	2,840	1,290	1,600	730	.19
• SB030XP0	3.000	3.625	3.231	3.393	1,340	580	3,350	1,440	2,220	960	.24
• SB035XP0	3.500	4.125	3.731	3.893	1,540	630	3,860	1,590	2,940	1,210	.27
• SB040XP0	4.000	4.625	4.231	4.393	1,750	690	4,370	1,720	3,770	1,490	.30



- ① Capacities listed are not simultaneous. For combined loading see discussion of Bearing Selection and Load Analysis. Dynamic capacities are based upon 1 million revolutions of L10 life. Published capacities do not apply to hybrid series bearings P, X, and Y - contact Kaydon product engineering for values.
- ② Static capacities are non-brinell limits based on rigid support from the shaft and housing.
- ③ "F" is the maximum shaft or housing fillet radius the bearing corners will clear.
  - Available from stock. All other – contact Kaydon for lead time.

# Kaydon Precision Tolerances and Recommended Fits for REALI-SLIM® Ball Bearings in Normal Applications

TYPE C - PRECISION CLASS 1 (REF. ABEC 1F)												
Bearing Size (All Series)	Bearing Diameters		Radial & Axial Runout		Rotating Shaft or Duplex DF Mounting		Stationary Shaft or Duplex DB Mounting				Bearing Diametral Clearance*	
	Bearing Bore	Bearing O.D.	Inner Race	Outer Race	Shaft Diameter	Housing Bore	Shaft Diameter		Housing Bore		Before Installation	
	Nominal +.0000	Nominal +.0000			Nominal +.0000	Nominal +.0000	Nominal		Nominal			
10	-.0004	-.0005	.0005	.0008	+.0004	+.0005	-.0004	-.0008	-.0005	-.0010	.0010	.0016
15	-.0005	-.0005	.0006	.0008	+.0005	+.0005	-.0005	-.0010	-.0005	-.0010	.0012	.0018
17	-.0006	-.0005	.0008	.0010	+.0006	+.0005	-.0006	-.0012	-.0005	-.0010	.0012	.0024
020	-.0006	-.0005	.0008	.0010	+.0006	+.0005	-.0006	-.0012	-.0005	-.0010	.0012	.0024
025	-.0006	-.0005	.0008	.0010	+.0006	+.0005	-.0006	-.0012	-.0005	-.0010	.0012	.0024
030	-.0006	-.0006	.0008	.0010	+.0006	+.0006	-.0006	-.0012	-.0006	-.0012	.0012	.0024
035	-.0008	-.0006	.0010	.0012	+.0008	+.0006	-.0008	-.0016	-.0006	-.0012	.0016	.0028
040	-.0008	-.0006	.0010	.0012	+.0008	+.0006	-.0008	-.0016	-.0006	-.0012	.0016	.0028
042	-.0008	-.0008	.0010	.0014	+.0008	+.0008	-.0008	-.0016	-.0008	-.0016	.0016	.0028
045	-.0008	-.0008	.0010	.0014	+.0008	+.0008	-.0008	-.0016	-.0008	-.0016	.0016	.0028
047	-.0010	-.0008	.0008	.0014	+.0010	+.0008	-.0010	-.0020	-.0008	-.0016	.0020	.0034
050	-.0010	-.0008	.0012	.0014	+.0010	+.0008	-.0010	-.0020	-.0008	-.0016	.0020	.0034
055	-.0010	-.0010	.0012	.0016	+.0010	+.0010	-.0010	-.0020	-.0010	-.0020	.0020	.0034
060	-.0010	-.0010	.0012	.0016	+.0010	+.0010	-.0010	-.0020	-.0010	-.0020	.0020	.0034
065	-.0010	-.0010	.0012	.0016	+.0010	+.0010	-.0010	-.0020	-.0010	-.0020	.0020	.0034
070	-.0010	-.0012	.0012	.0016	+.0010	+.0012	-.0010	-.0020	-.0012	-.0024	.0020	.0034
075	-.0012	-.0012	.0016	.0018	+.0012	+.0012	-.0012	-.0024	-.0012	-.0024	.0024	.0042
080	-.0012	-.0012	.0016	.0018	+.0012	+.0012	-.0012	-.0024	-.0012	-.0024	.0024	.0042
090	-.0012	-.0012	.0016	.0018	+.0012	+.0012	-.0012	-.0024	-.0012	-.0024	.0024	.0042
100	-.0014	-.0014	.0018	.0020	+.0014	+.0014	-.0014	-.0028	-.0014	-.0028	.0028	.0048
110	-.0014	-.0014	.0018	.0020	+.0014	+.0014	-.0014	-.0028	-.0014	-.0028	.0028	.0048
120	-.0014	-.0014	.0018	.0020	+.0014	+.0014	-.0014	-.0028	-.0014	-.0028	.0028	.0048
140	-.0016	-.0016	.0018	.0020	+.0016	+.0016	-.0016	-.0032	-.0016	-.0032	.0032	.0052
160	-.0018	-.0018	.0018	.0020	+.0018	+.0018	-.0018	-.0036	-.0018	-.0036	.0036	.0056
180	-.0018	-.0018	.0020	.0020	+.0018	+.0018	-.0018	-.0036	-.0018	-.0036	.0036	.0056
200	-.0020	-.0020	.0020	.0020	+.0020	+.0020	-.0020	-.0040	-.0020	-.0040	.0040	.0060
250	-.0030	-.0030	.0020	.0020	+.0030	+.0030	-.0030	-.0060	-.0030	-.0060	.0060	.0080
300	-.0030	-.0030	.0020	.0020	+.0030	+.0030	-.0030	-.0060	-.0030	-.0060	.0060	.0080
350	-.0040	-.0040	.0020	.0020	+.0040	+.0040	-.0040	-.0080	-.0040	-.0080	.0080	.0100
400	-.0040	-.0040	.0020	.0020	+.0040	+.0040	-.0040	-.0080	-.0040	-.0080	.0080	.0100

\* Diametral clearance after installation theoretically can range rather widely if all contributing bearing, housing, and shaft tolerances are at either of their extremes.

Race Width Tolerance:  
 Up thru 12" Bearing Bore +.000 -.005  
 Over 12" Bearing Bore +.000 -.010

Listed shaft and housing diameters are for steel supports with standard bearing diametral clearance. Recommended shaft and housing diameters can change greatly based on orientation, temperature, speed, non-standard diametral clearances, and desired performance characteristics. Contact Kaydon for design assistance when required.

All dimensions in inches.

**PRECISION TOLERANCES AND RECOMMENDED FITS**

<b>TYPE X AND A - PRECISION CLASS 1 (REF. ABEC 1F)</b>												
Bearing Size (All Series)	Bearing Diameters		Radial & Axial Runout		Rotating Shaft or Duplex DF Mounting		Stationary Shaft or Duplex DB Mounting				Bearing Diametral Clearance* (Type "X" only)	
	Bearing Bore	Bearing O.D.	Inner Race	Outer Race	Shaft Diameter	Housing Bore	Shaft Diameter		Housing Bore		Before Installation	
	Nominal +.0000	Nominal +.0000			Nominal +.0000	Nominal +.0000	Nominal		Nominal			
10	-.0004	-.0005	.0003	.0004	+.0004	+.0005	-.0004	-.0008	-.0005	-.0010	.0010	.0015
15	-.0005	-.0005	.0004	.0004	+.0005	+.0005	-.0005	-.0010	-.0005	-.0010	.0012	.0017
17	-.0006	-.0005	.0005	.0005	+.0006	+.0005	-.0006	-.0012	-.0005	-.0010	.0012	.0022
020	-.0006	-.0005	.0005	.0005	+.0006	+.0005	-.0006	-.0012	-.0005	-.0010	.0012	.0022
025	-.0006	-.0005	.0005	.0005	+.0006	+.0005	-.0006	-.0012	-.0005	-.0010	.0012	.0022
030	-.0006	-.0006	.0006	.0006	+.0006	+.0006	-.0006	-.0012	-.0006	-.0012	.0012	.0022
035	-.0008	-.0006	.0006	.0006	+.0008	+.0006	-.0008	-.0016	-.0006	-.0012	.0016	.0026
040	-.0008	-.0006	.0006	.0006	+.0008	+.0006	-.0008	-.0016	-.0006	-.0012	.0016	.0026
042	-.0008	-.0008	.0008	.0008	+.0008	+.0008	-.0008	-.0016	-.0008	-.0016	.0016	.0026
045	-.0008	-.0008	.0008	.0008	+.0008	+.0008	-.0008	-.0016	-.0008	-.0016	.0016	.0026
047	-.0010	-.0008	.0008	.0008	+.0010	+.0008	-.0010	-.0020	-.0008	-.0016	.0020	.0030
050	-.0010	-.0008	.0008	.0008	+.0010	+.0008	-.0010	-.0020	-.0008	-.0016	.0020	.0030
055	-.0010	-.0010	.0010	.0010	+.0010	+.0010	-.0010	-.0020	-.0010	-.0020	.0020	.0030
060	-.0010	-.0010	.0010	.0010	+.0010	+.0010	-.0010	-.0020	-.0010	-.0020	.0020	.0030
065	-.0010	-.0010	.0010	.0010	+.0010	+.0010	-.0010	-.0020	-.0010	-.0020	.0020	.0030
070	-.0010	-.0012	.0010	.0010	+.0010	+.0012	-.0010	-.0020	-.0012	-.0024	.0020	.0030
075	-.0012	-.0012	.0012	.0012	+.0012	+.0012	-.0012	-.0024	-.0012	-.0024	.0024	.0034
080	-.0012	-.0012	.0012	.0012	+.0012	+.0012	-.0012	-.0024	-.0012	-.0024	.0024	.0034
090	-.0012	-.0012	.0012	.0012	+.0012	+.0012	-.0012	-.0024	-.0012	-.0024	.0024	.0034
100	-.0014	-.0014	.0014	.0014	+.0014	+.0014	-.0014	-.0028	-.0014	-.0028	.0028	.0038
110	-.0014	-.0014	.0014	.0014	+.0014	+.0014	-.0014	-.0028	-.0014	-.0028	.0028	.0038
120	-.0014	-.0014	.0014	.0014	+.0014	+.0014	-.0014	-.0028	-.0014	-.0028	.0028	.0038
140	-.0014	-.0014	.0014	.0014	+.0014	+.0014	-.0014	-.0028	-.0014	-.0028	.0028	.0038
160	-.0016	-.0016	.0016	.0016	+.0016	+.0016	-.0016	-.0032	-.0016	-.0032	.0032	.0042
180	-.0016	-.0016	.0016	.0016	+.0016	+.0016	-.0016	-.0032	-.0016	-.0032	.0032	.0042
200	-.0018	-.0018	.0018	.0018	+.0018	+.0018	-.0018	-.0036	-.0018	-.0036	.0036	.0046
220	-.0018	-.0018	.0018	.0018	+.0018	+.0018	-.0018	-.0036	-.0018	-.0036	.0036	.0046
250	-.0018	-.0018	.0018	.0018	+.0018	+.0018	-.0018	-.0036	-.0018	-.0036	.0036	.0046
300	-.0018	-.0018	.0018	.0018	+.0018	+.0018	-.0018	-.0036	-.0018	-.0036	.0036	.0046
350	-.0020	-.0020	.0020	.0020	+.0020	+.0020	-.0020	-.0040	-.0020	-.0040	.0040	.0050
400	-.0020	-.0020	.0020	.0020	+.0020	+.0020	-.0020	-.0040	-.0020	-.0040	.0040	.0050

\* Diametral clearance after installation theoretically can range rather widely if all contributing bearing, housing, and shaft tolerances are at either of their extremes. Diametral clearances shown do not apply to Type A (angular contact) bearings.

Listed shaft and housing diameters are for steel supports with standard bearing diametral clearance. Recommended shaft and housing diameters can change greatly based on orientation, temperature, speed, non-standard diametral clearances, and desired performance characteristics. Contact Kaydon for design assistance when required.

All dimensions in inches.

Total Width Tolerance—Duplexed Type A Bearings:  
 Up thru 12" Bearing Bore +.000 -.010  
 Over 12" Bearing Bore +.000 -.020  
 Race Width Tolerance—Single Type C, X, A Bearings:  
 Up thru 12" Bearing Bore +.000 -.005  
 Over 12" Bearing Bore +.000 -.010

**PRECISION TOLERANCES AND RECOMMENDED FITS**

Section 2—Selection Tables

<b>TYPE C, X AND A - PRECISION CLASS 3 (REF. ABEC 3F)</b>												
Bearing Size (All Series)	Bearing Diameters		Radial & Axial Runout		Rotating Shaft or Duplex DF Mounting		Stationary Shaft or Duplex DB Mounting				Bearing Diametral Clearance* (Type "X" and "C" only)	
	Bearing Bore	Bearing O.D.	Inner Race	Outer Race	Shaft Diameter	Housing Bore	Shaft Diameter		Housing Bore		Before Installation	
	Nominal +.0000	Nominal +.0000			Nominal +.0000	Nominal +.0000	Nominal		Nominal			
10	-.0002	-.0003	.0003	.0004	+.0002	+.0003	-.0002	-.0004	-.0003	-.0006	.0007	.0011
15	-.0003	-.0003	.0004	.0004	+.0003	+.0003	-.0003	-.0006	-.0003	-.0006	.0008	.0012
17	-.0004	-.0004	.0004	.0005	+.0004	+.0004	-.0004	-.0008	-.0004	-.0008	.0008	.0018
020	-.0004	-.0004	.0004	.0005	+.0004	+.0004	-.0004	-.0008	-.0004	-.0008	.0008	.0018
025	-.0004	-.0004	.0004	.0005	+.0004	+.0004	-.0004	-.0008	-.0004	-.0008	.0008	.0018
030	-.0004	-.0004	.0004	.0006	+.0004	+.0004	-.0004	-.0008	-.0004	-.0008	.0008	.0018
035	-.0005	-.0004	.0005	.0006	+.0005	+.0004	-.0005	-.0010	-.0004	-.0008	.0010	.0020
040	-.0005	-.0004	.0005	.0006	+.0005	+.0004	-.0005	-.0010	-.0004	-.0008	.0010	.0020
042	-.0005	-.0005	.0005	.0008	+.0005	+.0005	-.0005	-.0010	-.0005	-.0010	.0010	.0020
045	-.0005	-.0005	.0005	.0008	+.0005	+.0005	-.0005	-.0010	-.0005	-.0010	.0010	.0020
047	-.0006	-.0005	.0006	.0008	+.0006	+.0005	-.0006	-.0012	-.0005	-.0010	.0012	.0022
050	-.0006	-.0005	.0006	.0008	+.0006	+.0005	-.0006	-.0012	-.0005	-.0010	.0012	.0022
055	-.0006	-.0006	.0006	.0009	+.0006	+.0006	-.0006	-.0012	-.0006	-.0012	.0012	.0022
060	-.0006	-.0006	.0006	.0009	+.0006	+.0006	-.0006	-.0012	-.0006	-.0012	.0012	.0022
065	-.0006	-.0006	.0006	.0009	+.0006	+.0006	-.0006	-.0012	-.0006	-.0012	.0012	.0022
070	-.0006	-.0007	.0006	.0010	+.0006	+.0007	-.0006	-.0012	-.0007	-.0014	.0014	.0024
075	-.0007	-.0007	.0008	.0010	+.0007	+.0007	-.0007	-.0014	-.0007	-.0014	.0014	.0024
080	-.0007	-.0007	.0008	.0010	+.0007	+.0007	-.0007	-.0014	-.0007	-.0014	.0014	.0024
090	-.0007	-.0007	.0008	.0010	+.0007	+.0007	-.0007	-.0014	-.0007	-.0014	.0014	.0024
100	-.0008	-.0008	.0010	.0012	+.0008	+.0008	-.0008	-.0016	-.0008	-.0016	.0016	.0026
110	-.0008	-.0008	.0010	.0012	+.0008	+.0008	-.0008	-.0016	-.0008	-.0016	.0016	.0026
120	-.0008	-.0009	.0010	.0014	+.0008	+.0009	-.0008	-.0016	-.0009	-.0018	.0018	.0028
140	-.0008	-.0009	.0012	.0014	+.0008	+.0009	-.0008	-.0016	-.0009	-.0018	.0018	.0028
160	-.0009	-.0010	.0014	.0016	+.0009	+.0010	-.0009	-.0018	-.0010	-.0020	.0020	.0030
180	-.0009	-.0010	.0014	.0016	+.0009	+.0010	-.0009	-.0018	-.0010	-.0020	.0020	.0030
200	-.0010	-.0012	.0016	.0018	+.0010	+.0012	-.0010	-.0020	-.0012	-.0024	.0024	.0034

\* Diametral clearance after installation theoretically can range rather widely if all contributing bearing, housing, and shaft tolerances are at either of their extremes. Diametral clearances shown do not apply to Type A (angular contact) bearings.

Listed shaft and housing diameters are for steel supports with standard bearing diametral clearance. Recommended shaft and housing diameters can change greatly based on orientation, temperature, speed, non-standard diametral clearances, and desired performance characteristics. Contact Kaydon for design assistance when required.

All dimensions in inches.

Total Width Tolerance—Duplexed Type A Bearings:  
 Up thru 12" Bearing Bore +.000 - .010  
 Over 12" Bearing Bore +.000 - .020  
 Race Width Tolerance—Single Type C, X, A Bearings:  
 Up thru 12" Bearing Bore +.000 - .005  
 Over 12" Bearing Bore +.000 - .010



**PRECISION TOLERANCES AND RECOMMENDED FITS**

**TYPE C, X AND A - PRECISION CLASS 4 (REF. ABEC 5F)**

Bearing Size (All Series)	Bearing Diameters		Radial & Axial Runout				Rotating Shaft or Duplex DF Mounting		Stationary Shaft or Duplex DB Mounting				Bearing Diametral Clearance* (Type "X" and "C" only)	
	Bearing Bore	Bearing O.D.					Shaft Diameter	Housing Bore	Shaft Diameter	Housing Bore	Before Installation			
	Nominal +.0000	Nominal +.0000	Inner Race	Outer Race	Nominal +.0000	Nominal +.0000	Nominal	Nominal						
10	-.0002	-.0002	R.0002, A.0003	R.0002, A.0003	+.0002	+.0002	-.0002	-.0004	-.0002	-.0004	.0005	.0009		
15	-.0002	-.0002	R.0002, A.0003	R.0002, A.0003	+.0002	+.0002	-.0002	-.0004	-.0002	-.0004	.0005	.0009		
17	-.0003	-.0003	R.0002, A.0003	R.0003, A.0004	+.0003	+.0003	-.0003	-.0006	-.0003	-.0006	.0006	.0012		
020	-.0003	-.0003	R.0002, A.0003	R.0003, A.0004	+.0003	+.0003	-.0003	-.0006	-.0003	-.0006	.0006	.0012		
025	-.0003	-.0003	R.0002, A.0003	R.0003, A.0004	+.0003	+.0003	-.0003	-.0006	-.0003	-.0006	.0006	.0012		
030	-.0003	-.0003	R.0002, A.0003	R.0004, A.0005	+.0003	+.0003	-.0003	-.0006	-.0003	-.0006	.0006	.0012		
035	-.0003	-.0003	R.0003, A.0004	R.0004, A.0005	+.0003	+.0003	-.0003	-.0006	-.0003	-.0006	.0006	.0012		
040	-.0003	-.0003	R.0003, A.0004	R.0004, A.0005	+.0003	+.0003	-.0003	-.0006	-.0003	-.0006	.0006	.0012		
042	-.0003	-.0004	R.0003, A.0004	R.0004, A.0005	+.0003	+.0004	-.0003	-.0006	-.0004	-.0008	.0008	.0014		
045	-.0003	-.0004	R.0003, A.0004	R.0004, A.0005	+.0003	+.0004	-.0003	-.0006	-.0004	-.0008	.0008	.0014		
047	-.0004	-.0004	R.0003, A.0004	R.0004, A.0005	+.0004	+.0004	-.0004	-.0008	-.0004	-.0008	.0008	.0014		
050	-.0004	-.0004	R.0003, A.0004	R.0004, A.0005	+.0004	+.0004	-.0004	-.0008	-.0004	-.0008	.0008	.0014		
055	-.0004	-.0005	R.0003, A.0004	R.0005, A.0006	+.0004	+.0005	-.0004	-.0008	-.0005	-.0010	.0010	.0016		
060	-.0004	-.0005	R.0003, A.0004	R.0005, A.0006	+.0004	+.0005	-.0004	-.0008	-.0005	-.0010	.0010	.0016		
065	-.0004	-.0005	R.0003, A.0004	R.0005, A.0006	+.0004	+.0005	-.0004	-.0008	-.0005	-.0010	.0010	.0016		
070	-.0004	-.0005	R.0003, A.0004	R.0005, A.0006	+.0004	+.0005	-.0004	-.0008	-.0005	-.0010	.0010	.0016		
075	-.0005	-.0005	R.0004, A.0005	R.0005, A.0006	+.0005	+.0005	-.0005	-.0010	-.0005	-.0010	.0010	.0016		
080	-.0005	-.0005	R.0004, A.0005	R.0005, A.0006	+.0005	+.0005	-.0005	-.0010	-.0005	-.0010	.0010	.0016		
090	-.0005	-.0005	R.0004, A.0005	R.0005, A.0006	+.0005	+.0005	-.0005	-.0010	-.0005	-.0010	.0010	.0016		
100	-.0005	-.0005	R.0005, A.0006	R.0006, A.0007	+.0005	+.0005	-.0005	-.0010	-.0005	-.0010	.0010	.0016		
110	-.0005	-.0005	R.0005, A.0006	R.0006, A.0007	+.0005	+.0005	-.0005	-.0010	-.0005	-.0010	.0010	.0016		
120	-.0005	-.0006	R.0005, A.0006	R.0007, A.0008	+.0005	+.0006	-.0005	-.0010	-.0006	-.0012	.0012	.0018		
140	-.0006	-.0006	R.0005, A.0007	R.0007, A.0008	+.0006	+.0006	-.0006	-.0012	-.0006	-.0012	.0012	.0018		
160	-.0006	-.0007	R.0007, A.0008	R.0008, A.0009	+.0006	+.0007	-.0006	-.0012	-.0007	-.0014	.0014	.0020		
180	-.0006	-.0007	R.0007, A.0008	R.0008, A.0009	+.0006	+.0007	-.0006	-.0012	-.0007	-.0014	.0014	.0020		
200	-.0007	-.0008	R.0008, A.0009	R.0009, A.0010	+.0007	+.0008	-.0006	-.0014	-.0007	-.0016	.0014	.0022		

\* Diametral clearance after installation theoretically can range rather widely if all contributing bearing, housing, and shaft tolerances are at either of their extremes. Diametral clearances shown do not apply to Type A (angular contact) bearings.

Listed shaft and housing diameters are for steel supports with standard bearing diametral clearance. Recommended shaft and housing diameters can change greatly based on orientation, temperature, speed, non-standard diametral clearances, and desired performance characteristics. Contact Kaydon for design assistance when required.

All dimensions in inches.

Total Width Tolerance—Duplexed Type A Bearings:  
 Up thru 12" Bearing Bore +.000 -.010  
 Over 12" Bearing Bore +.000 -.020  
 Race Width Tolerance—Single Type C, X, A Bearings:  
 Up thru 12" Bearing Bore +.000 -.005  
 Over 12" Bearing Bore +.000 -.010

**PRECISION TOLERANCES AND RECOMMENDED FITS**

Section 2—Selection Tables

<b>TYPE C, X AND A - PRECISION CLASS 6 (REF. ABEC 7F)</b>												
Bearing Size (All Series)	Bearing Diameters		Radial & Axial Runout		Rotating Shaft or Duplex DF Mounting		Stationary Shaft or Duplex DB Mounting				Bearing Diametral Clearance* (Type "X" and "C" only)	
	Bearing Bore	Bearing O.D.	Inner Race	Outer Race	Shaft Diameter	Housing Bore	Shaft Diameter		Housing Bore		Before Installation	
	Nominal +.0000	Nominal +.0000			Nominal +.0000	Nominal +.0000	Nominal		Nominal			
10	-.00015	-.00020	.00015	.0002	+.00015	+.00020	-.00015	-.00030	-.00020	-.00040	.0004	.0008
15	-.00020	-.00020	.00015	.0002	+.00020	+.00020	-.00020	-.00040	-.00020	-.00040	.0005	.0009
17	-.0002	-.0002	.00015	.0002	+.0002	+.0002	-.0002	-.0004	-.0002	-.0004	.0004	.0010
020	-.0002	-.0002	.00015	.0002	+.0002	+.0002	-.0002	-.0004	-.0002	-.0004	.0004	.0010
025	-.0002	-.0002	.00015	.0002	+.0002	+.0002	-.0002	-.0004	-.0002	-.0004	.0004	.0010
030	-.0002	-.0003	.00015	.0002	+.0002	+.0003	-.0002	-.0004	-.0003	-.0006	.0006	.0012
035	-.00025	-.00030	.0002	.0002	+.00025	+.00030	-.00025	-.00050	-.00030	-.00060	.0006	.0012
040	-.00025	-.00030	.0002	.0002	+.00025	+.00030	-.00025	-.00050	-.00030	-.00060	.0006	.0012
042	-.00025	-.00040	.0002	.0003	+.00025	+.00040	-.00025	-.00050	-.00040	-.00080	.0008	.0014
045	-.00025	-.00040	.0002	.0003	+.00025	+.00040	-.00025	-.00050	-.00040	-.00080	.0008	.0014
047	-.0003	-.0004	.0003	.0003	+.0003	+.0004	-.0003	-.0006	-.0004	-.0008	.0008	.0014
050	-.0003	-.0004	.0003	.0003	+.0003	+.0004	-.0003	-.0006	-.0004	-.0008	.0008	.0014
055	-.0003	-.0004	.0003	.0003	+.0003	+.0004	-.0003	-.0006	-.0004	-.0008	.0008	.0014
060	-.0003	-.0004	.0003	.0003	+.0003	+.0004	-.0003	-.0006	-.0004	-.0008	.0008	.0014
065	-.0003	-.0004	.0003	.0003	+.0003	+.0004	-.0003	-.0006	-.0004	-.0008	.0008	.0014
070	-.0003	-.0004	.0003	.0004	+.0003	+.0004	-.0003	-.0006	-.0004	-.0008	.0008	.0014
075	-.0004	-.0004	.0003	.0004	+.0004	+.0004	-.0004	-.0008	-.0004	-.0008	.0008	.0014
080	-.0004	-.0004	.0003	.0004	+.0004	+.0004	-.0004	-.0008	-.0004	-.0008	.0008	.0014
090	-.0004	-.0004	.0003	.0004	+.0004	+.0004	-.0004	-.0008	-.0004	-.0008	.0008	.0014
100	-.0005	-.0005	.0004	.0004	+.0005	+.0005	-.0005	-.0010	-.0005	-.0010	.0010	.0016
110	-.0005	-.0005	.0004	.0004	+.0005	+.0005	-.0005	-.0010	-.0005	-.0010	.0010	.0016
120	-.0005	-.0005	.0004	.0005	+.0005	+.0005	-.0005	-.0010	-.0005	-.0010	.0010	.0016
140	-.0005	-.0006	.0004	.0005	+.0005	+.0006	-.0005	-.0010	-.0006	-.0012	.0012	.0018

\* Diametral clearance after installation theoretically can range rather widely if all contributing bearing, housing, and shaft tolerances are at either of their extremes. Diametral clearances shown do not apply to Type A (angular contact) bearings.

Listed shaft and housing diameters are for steel supports with standard bearing diametral clearance. Recommended shaft and housing diameters can change greatly based on orientation, temperature, speed, non-standard diametral clearances, and desired performance characteristics. Contact Kaydon for design assistance when required.

All dimensions in inches.

Total Width Tolerance—Duplexed Type A Bearings:  
 Up thru 12" Bearing Bore +.000 - .010  
 Over 12" Bearing Bore +.000 - .020  
 Race Width Tolerance—Single Type C, X, A Bearings:  
 Up thru 12" Bearing Bore +.000 - .005  
 Over 12" Bearing Bore +.000 - .010

# Endurakote® Plating for Corrosion-Resistant Bearings (Series L, N)

## Introduction

Endurakote® plating protects bearings from corrosion and provides substantial life improvements in hostile environments. Endurakote is applied over conventional bearing materials such as 52100 steel, and offers the benefit of corrosion resistance normally found only in stainless steel bearings. The coating is applied to the entire bearing race rings, including the paths, thus leaving no area exposed. Other commercial chrome or cadmium coatings normally accepted and used cannot be applied to the path due to the rolling contact stresses. Endurakote plating is hard chromium, electrodeposited by a proprietary process which achieves a true molecular bond, and will not flake or peel even under the high contact stresses experienced in the bearing paths.

Laboratory and field testing results have proven the benefits of this process. Severe salt spray testing has shown that bearings with Endurakote plating withstand corrosion as well as or better than 440C stainless steel. The hard, dense exterior surface formed by the coating is extremely wear resistant and is excellent in the retention of the lubricant film. Conventional life testing of 52100 steel bearings with Endurakote plating has shown that no life de-rating is necessary. In fact, the extremely hard surface of Endurakote plating protects the bearing from surface generated damage which can promote premature failure. Since the coating is capable of withstanding extremely high temperatures, the bearings are limited by the bearing materials or lubricant used.

The coating used for Endurakote plating can be applied to any type of bearing and to most bearing materials. Its primary advantage is to utilize stock materials such as 52100, etc. with their economies, and convert them to wear and corrosion resistant bearings. This is particularly beneficial for larger diameter bearings or where quick delivery is critical. Thus, cost savings can be achieved over more exotic or specialized materials. Also, stock bearings can have Endurakote plating applied for quick delivery.

The net result is that we can offer bearings with the capacity of conventional bearing steels and the corrosion resistance of 440C stainless steel from standard 52100 stock components.

## Application

Endurakote provides corrosion resistance and is effective in increasing wear resistance in sliding surface contacts such as the lands where the cage pilots. The micro-surface composition of Endurakote plating aids in lubricant dispersion, enhancing base metals to the degree of reducing or eliminating galling, seizing, and high friction, over a wide range of installations and environments.

## Advantages

Endurakote plating effects a buildup of less than .0002 under normal circumstances. Thus, it can often be applied to stock bearing components which have been specially selected. Endurakote plating is compatible with most ferrous and non-ferrous metal, allowing maximum flexibility in selection of base material. Endurakote plating is normally a final process, and its quality is constant with any given base metal, insuring design reproducibility.

## Properties and Characteristics

### A. Hardness

Endurakote plating, as deposited, has an equivalent hardness in excess of 70 Rockwell "C." When measured by conventional micro-hardness methods, the host material will modify this measurement to some degree.

### B. Coefficient of Friction

(Note: Measurements made at 72°, using other materials for comparison.)

Material	Against	Material	Static	—	Sliding
Steel		Steel	0.30	—	0.20
Steel		Brass, Bronze	0.25	—	0.20
Steel		Endurakote	0.17	—	0.16
Brass, Bronze		Endurakote	0.15	—	0.13
Endurakote		Endurakote	0.14	—	0.12

### C. Adhesion

Endurakote® will not flake, crack, chip, peel or otherwise separate from the base material under standard bend tests or under conditions where severe heat is induced. In an extensive testing program at Kaydon the adherence proved adequate to withstand the extremely high compressive stresses in the contact areas of ball and roller bearings.

### D. Effect On Base

The purity of the chromium surface will not be less than 99% as deposited. A comprehensive testing program at Kaydon established that bearings with Endurakote exhibited load carrying capacities and life expectancy equal to or better than uncoated 52100 steel bearings.

### E. Corrosion Resistance

Endurakote resists attack by most organic and inorganic compounds with a pH within the range of 4 and 11 except sulfuric and hydrochloric acids. Porosity of the base metal, compound concentration and exposure time to the compound become corrosion factors, but Endurakote greatly enhances the base material. In severe salt spray tests as well as tap water immersion tests, 52100 steel with Endurakote proved equal to fully hardened 440C stainless steel in resistance to rusting. Endurakote is better for corrosion protection in many instances, than cadmium plate, zinc plate, phosphates, chromates, black oxide and normal chrome plate. We invite inquiries about and will be pleased to arrange tests to qualify Endurakote for specific environments.

### F. Heat Resistance

Endurakote will withstand temperatures of -400°F to 2300°F. Hardness and wear resistance properties can be affected at temperatures above 700°F. At temperatures above 1300°F Endurakote will react with carbon monoxide, sulfur vapor and phosphorus. With bright red heat, oxidation occurs in steam or alkali hydroxide atmospheres. (Note: Suitability for use at elevated temperatures is dependent upon the base material, which must be selected for adequate physical properties at the expected temperature range.) Standard Reali-Slim® bearings are heat treated for dimensional stability over an operating temperature of -65°F to 250°F.

### G. Surface Quality

Endurakote conforms to the texture of the existing surface. R.M.S. finish will be improved slightly down to about 8 R.M.S., below 4 R.M.S. there is little change. Endurakote has a mat or micro-orange peel surface with very good lubricant retention qualities.

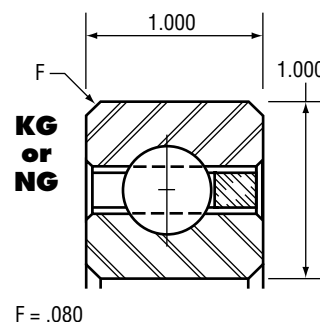
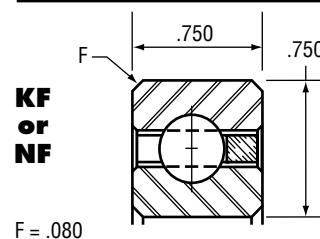
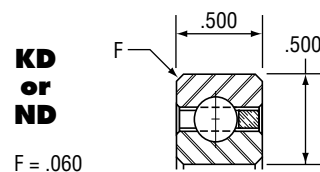
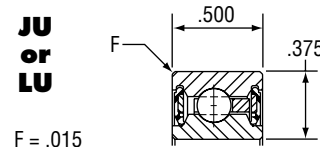
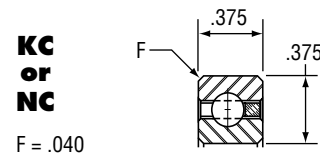
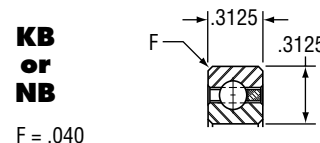
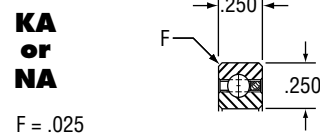
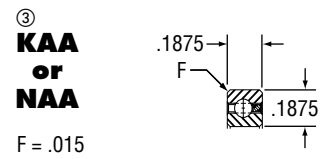
I. Endurakote coating is FDA approved for use in the food industries.

### Bearing Size Capabilities

Endurakote can be applied to any Reali-Slim® bearing.

# Comparative Tolerances for Endura-Slim® Bearings

Basic Bearing Bore Size (Inches)	Type	REALI-SLIM®		ENDURA-SLIM®		Runouts Radial & Axial		Diametral Clearance Type C & X Only	
		Bearing Bore Nominal +.0000	Bearing O.D. Nominal +.0000	Bearing Bore Nominal +.0000	Bearing O.D. Nominal +.0000	Inner Race	Outer Race	Before Installation	
								Min.	Max.
1.0	C	-.0004	-.0005	-.0006	-.0007	.0005	.0008	.0010	.0016
	A, X	-.0004	-.0005	-.0006	-.0007	.0003	.0004	.0010	.0015
1.5	C	-.0005	-.0005	-.0007	-.0007	.0006	.0008	.0012	.0018
	A, X	-.0005	-.0005	-.0007	-.0007	.0004	.0004	.0012	.0017
1.7	C	-.0006	-.0005	-.0008	-.0007	.0008	.0010	.0012	.0024
	A, X	-.0006	-.0005	-.0008	-.0007	.0005	.0005	.0012	.0022
2.0 to 2.5	C	-.0006	-.0005	-.0008	-.0007	.0008	.0010	.0012	.0024
	A, X	-.0006	-.0005	-.0008	-.0007	.0005	.0005	.0012	.0022
3.0	C	-.0006	-.0006	-.0008	-.0008	.0008	.0010	.0012	.0024
	A, X	-.0006	-.0006	-.0008	-.0008	.0006	.0006	.0012	.0022
3.5	C	-.0008	-.0006	-.0010	-.0008	.0010	.0012	.0016	.0028
	A, X	-.0008	-.0006	-.0010	-.0008	.0006	.0006	.0016	.0026
4.0	C	-.0008	-.0006	-.0009	-.0007	.0010	.0012	.0016	.0028
	A, X	-.0008	-.0006	-.0009	-.0007	.0006	.0006	.0016	.0026
4.2 to 4.5	C	-.0008	-.0008	-.0009	-.0009	.0010	.0014	.0016	.0028
	A, X	-.0008	-.0008	-.0009	-.0009	.0008	.0008	.0016	.0026
4.7 to 5.0	C	-.0010	-.0008	-.0011	-.0009	.0012	.0014	.0020	.0034
	A, X	-.0010	-.0008	-.0011	-.0009	.0008	.0008	.0020	.0030
5.5 to 6.5	C	-.0010	-.0010	-.0011	-.0011	.0012	.0016	.0020	.0034
	A, X	-.0010	-.0010	-.0011	-.0011	.0010	.0010	.0020	.0030
7.0	C	-.0010	-.0012	-.0011	-.0013	.0012	.0016	.0020	.0034
	A, X	-.0010	-.0012	-.0011	-.0013	.0010	.0010	.0020	.0030
7.5 to 9.0	C	-.0012	-.0012	-.0013	-.0013	.0016	.0018	.0024	.0042
	A, X	-.0012	-.0012	-.0013	-.0013	.0012	.0012	.0024	.0034
10.0 to 12.0	C	-.0014	-.0014	-.0015	-.0015	.0018	.0020	.0028	.0048
	A, X	-.0014	-.0014	-.0015	-.0015	.0014	.0014	.0028	.0038
14.0	C	-.0016	-.0016	-.0017	-.0017	.0018	.0020	.0032	.0052
	A, X	-.0014	-.0014	-.0015	-.0015	.0014	.0014	.0028	.0038
16.0	C	-.0018	-.0018	-.0019	-.0019	.0018	.0020	.0036	.0056
	A, X	-.0016	-.0016	-.0017	-.0017	.0016	.0016	.0032	.0042
18.0	C	-.0018	-.0018	-.0019	-.0019	.0020	.0020	.0036	.0056
	A, X	-.0016	-.0016	-.0017	-.0017	.0016	.0016	.0032	.0042
20.0	C	-.0020	-.0020	-.0021	-.0021	.0020	.0020	.0040	.0060
	A, X	-.0018	-.0018	-.0019	-.0019	.0018	.0018	.0036	.0046
25.0 to 30.0	C	-.0030	-.0030	-.0031	-.0031	.0020	.0020	.0060	.0080
	A, X	-.0018	-.0018	-.0019	-.0019	.0018	.0018	.0036	.0046
35.0 to 40.0	C	-.0040	-.0040	-.0041	-.0041	.0020	.0020	.0080	.0100
	A, X	-.0020	-.0020	-.0021	-.0021	.0020	.0020	.0040	.0050



**FITS**

**Rotating Shaft**

Shaft – Tight, zero to 2X bearing bore tolerance.

Housing – Loose, zero to 2X bearing O.D. tolerance.

**Stationary Shaft**

Shaft – Tight, zero to 2X bearing bore tolerance.

Housing – Loose, zero to 2X bearing O.D. tolerance.

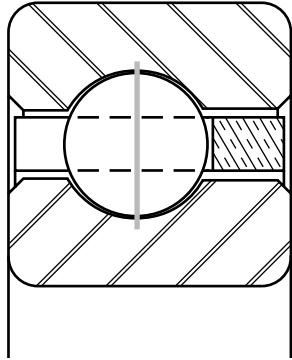
Listed shaft and housing diameters are for steel under normal conditions. Recommended diameters can change greatly based on orientation, temperature, speed, and other performance requirements. Consult Kaydon.

## **Section 3—Applications Engineering**

- **Selection Recommendations .....pgs.47-51**
- **Capacity, Life, and Load Analysis.....pgs.52-56**
- **Mounting Recommendations .....pgs.57-61**
  - **Accuracy**
  - **Load**
  - **Speed**
  - **Other Considerations**

# Bearing Selection

## Type C—Radial Contact



The Type C Radial Contact ball bearing is a single-row radial ball bearing with extra deep ball grooves in both rings (groove depth = 25% of ball diameter). Normally this bearing is assembled by eccentric displacement of the inner race within the outer race which permits insertion of about half of a full complement of balls. After insertion of the balls, the races are positioned concentrically and the balls are spaced about the entire circumference for assembly of the separator. This method of assembly is commonly termed “Conrad Assembly.”

An alternate method of assembly is to insert balls through a “filling slot” made by notching the raceway shoulder of one or both races. This method permits assembly with up to a full complement of balls for additional load capacity, however, there are limitations on the operating conditions and these are discussed under Separator Types.

Type C bearings perform best with a small amount of clearance between the balls and races (diametral clearance). Standard bearings are supplied with clearances for:

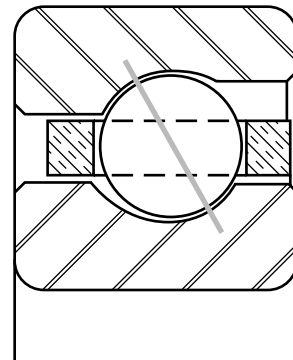
- Interference fitting between bearing races and mounting members;
- Differential thermal expansion or contraction of steel races;
- Misalignment between shaft and housing and other factors may require the clearance to be adjusted accordingly.

The Type C radial contact bearing is designed to have ball to race contact in the plane of the ball centers when pure radial load is applied and thrust forces are absent. Necessary diametral clearance may be increased or decreased to meet operating conditions.

While designed primarily for radial load application, the Type C bearing, without a filling slot, will accept some axial (thrust) load in either direction. Its ability to resist axial load, however, is dependent upon the amount of clearance in the bearing after installation. It is this clearance which allows the balls, under axial load, to contact the races at an angle, thereby offering resistance to such load. In the case of the bearing with a filling slot, the notches interrupt the ball contact paths under axial load, minimizing the dynamic thrust capability. Where axial load is present, therefore, rotation of the filling slot bearing must be restricted.

By increasing the diametral clearance beyond the standard amount, the Type C bearing can have a greater angle of contact under axial load, and thus greater thrust capacity. In this case, it is proper to adjust the bearing against another bearing of similar construction to reduce axial movement under reversing thrust forces. Used in this manner, the bearing is essentially an angular contact rather than a radial contact bearing.

## Type A—Angular Contact



Type A Angular Contact ball bearings differ from Type C bearings in that Type A bearings have sufficient diametral clearance to produce a substantial angle of contact for resistance to axial load. This contact angle is 30° in the standard bearing. As in the Type C bearing, extra deep ball grooves are used (25% of ball diameter).

The distinguishing feature of the Type A bearing lies in the method of assembly. One ring, usually the outer, is counter-bored to reduce one shoulder of the raceway to the extent that with the assistance of a temperature differential between the two rings, the outer ring can be installed over the inner race, ball, and separator assembly. This provides a non-separable bearing capable of carrying greater radial loads while resisting a substan-

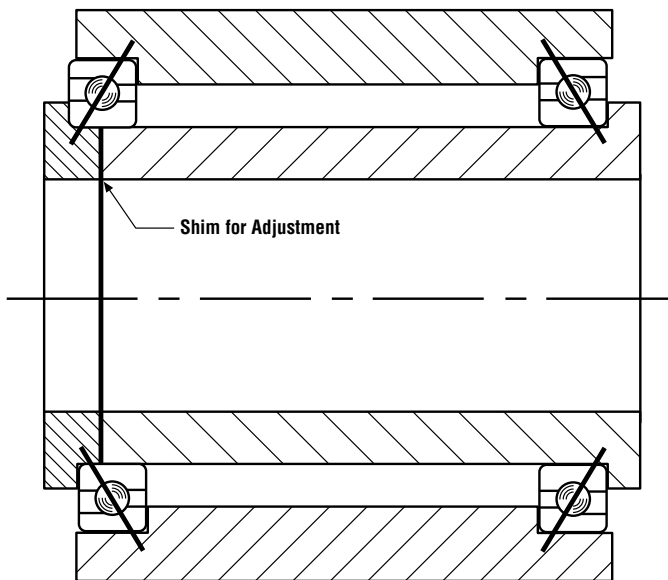
capable of carrying greater radial loads while resisting a substantial axial force in one direction. With an axial force applied, the faces of the inner and outer rings are approximately flush to minimize preload adjustments .

This assembly method permits the use of a greater complement of balls than is possible in the Type C bearing without filling slots, and together with the sizable contact angle, gives the Type A bearing its greater thrust capacity.

Because of its uni-directional thrust capability, this bearing should be mounted opposed to another bearing such that an axial force is present to establish and maintain the contact angle and to minimize axial movement under reversing thrust loads.

### Back-to-back Mounting

Figure 20

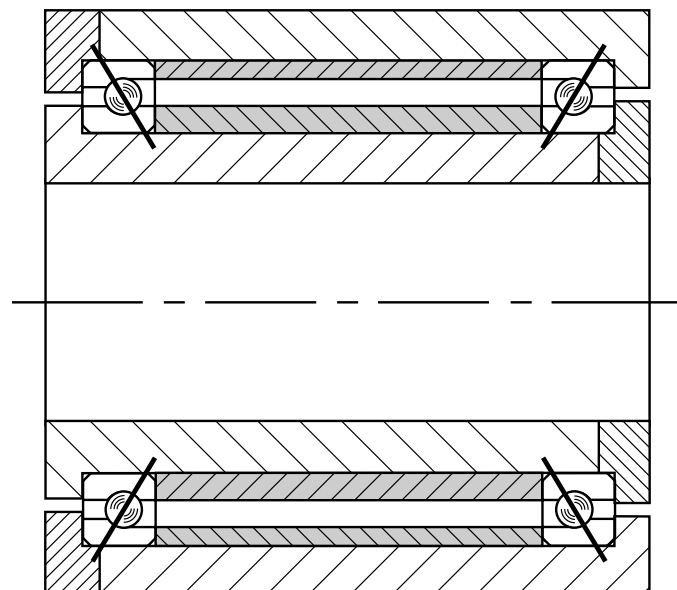


Typical mountings of Type A bearings are shown in Figure 20 and 21. In Figure 20, the bearings are mounted with the lines of contact converging outside of the bearings. This is commonly called a “back-to-back” mounting. In this figure, the bearings are adjustable through the inner races by use of shims under the

inner race clamping ring. Sufficient shim thickness is provided initially to allow axial movement of the shaft relative to the housing. The total axial movement can then be measured and the shim thickness reduced by the amount of movement plus any additional amount desired for preload. When two bearings are opposed to each other to the extent that all internal clearance is removed and elastic deformation occurs between the balls and raceways, the bearings are said to be “preloaded.”

### Face-to-face Mounting

Figure 21



In Figure 21, the bearings are mounted “face-to-face” with the contact lines converging inward. Spacers are used between both the inner and outer races and adjustment is possible by varying the length of one spacer relative to the other. Normally, however, the spacers are equal in length and the bearings are furnished as a matched pair with a predetermined internal fit. If the outer race spacer were removed from this assembly, the bearings could be adjusted by use of shims under the outer race clamping ring.



## Duplexed Bearings

Type A bearings are furnished as matched sets when they are to be mounted adjacent or with equal length inner and outer race spacers. When required, Kaydon can supply assemblies with matched ground spacers. The arrangements shown in Figures 22, 23, and 24 are known as duplexed bearings—back-to-back, face-to-face, and tandem, respectively. Sets of three, four or more bearings can also be matched where conditions require additional capacity and there is insufficient space radially for larger bearings.

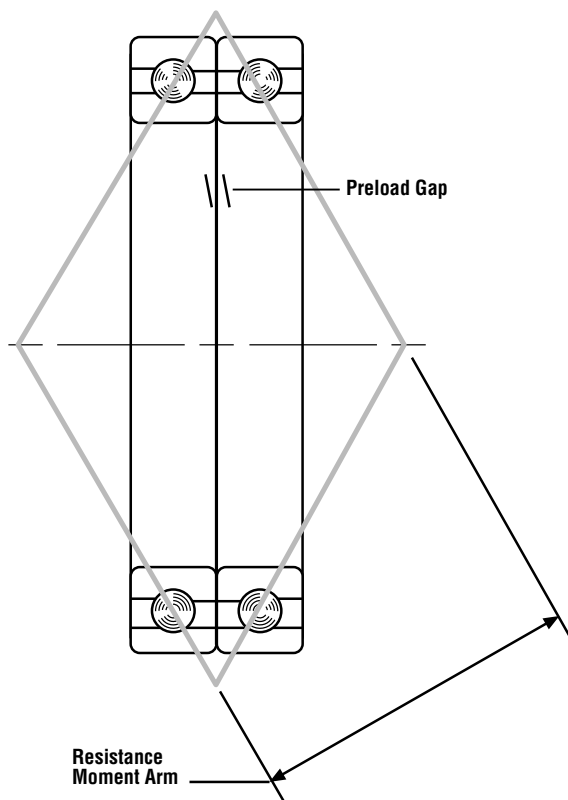
The bearings in these sets are matched within close limits for size of bore and outside diameter. Each set is marked with a “V” across the bores and outside diameters at the high point of radial runout and indicate the proper orientation of the races at installation (Figure 24).

The pairs shown in Figures 22 and 23 are normally furnished

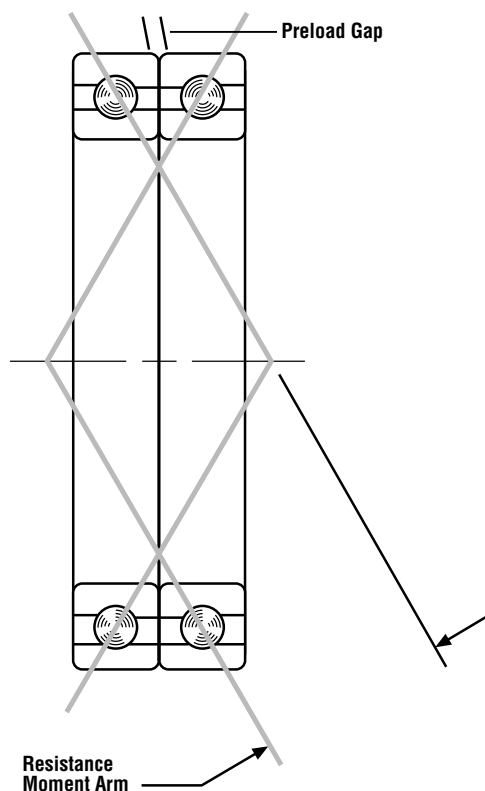
with the race faces ground to provide preload when installed. To accomplish this, a gap is provided between the inner races of the pair in Figure 22 and between the outer races of the pair in Figure 23. When the bearings are installed and clamped axially, the gap is closed producing a preload on the bearings.

- Back-to-back arrangement of Figures 20 and 22 offers greater rigidity under moment loading and should be used when the space between single bearings is small or when a single pair of adjacent bearings is employed.
- Face-to-face arrangement is more tolerant of misalignment between the shaft and housing and should be considered when there are multiple pairs of bearings along an axis. When single bearings are mounted face-to-face, they must be spaced sufficiently to provide resistance to moment load. If required, a face-to-face pair can be mounted in conjunction with another bearing in a “fixed-float” arrangement with the pair in the fixed position. (Also see page 60).

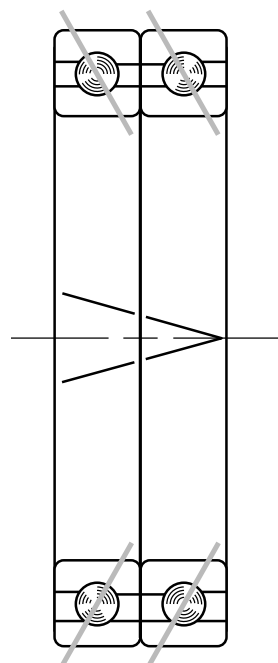
**Figure 22**  
**Back-to-back (Type DB)**



**Figure 23**  
**Face-to-face (Type DF)**



**Figure 24**  
**Tandem (Type DT)**

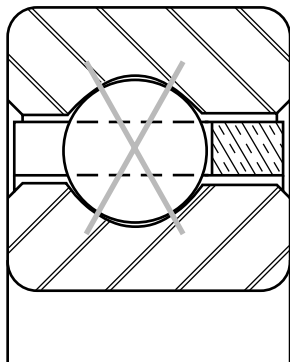


- **Tandem bearing** sets have single direction thrust capacity and must be mounted opposed to another bearing or set.

When applying catalog load ratings to matched sets, the total radial capacity is considered equal to the single bearing radial rating multiplied by  $N^{0.7}$ , where N is the number of bearings in the set. The thrust capacity in each direction is considered equal to the single bearing thrust rating multiplied by  $N^{0.7}$ , where N is the number of bearings resisting thrust in that direction.

Unless specifically requested, the outboard faces of bearing sets are not controlled. If outboard face flushness is required for pre-load purposes, universally ground bearings should be considered. On universally ground bearings, both inboard and outboard faces are matched under a specified gage load to control preload and allow for mounting orientation flexibility.

**Type X—Four Point Contact**



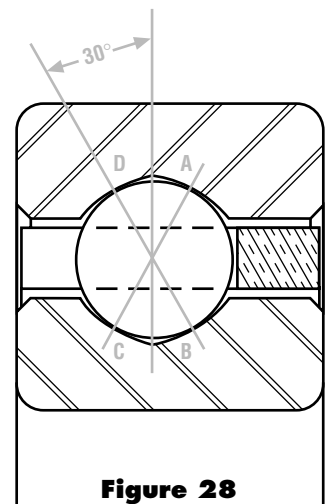
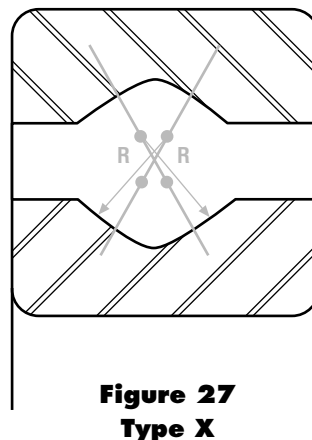
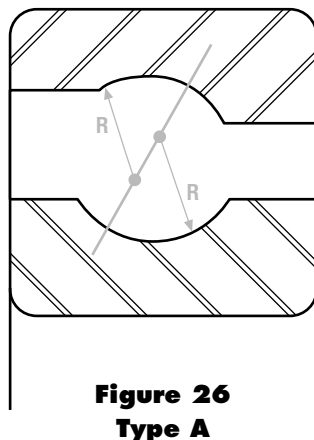
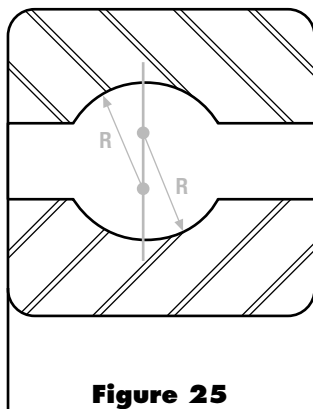
The Type X Four-Point Contact ball bearing is distinguished from Types A and C by the geometry of its ball grooves. In Type C, the centers of the radii both lie in the plane of the ball

centers (Figure 25). In Type A with the races and balls in angular contact, the centers of the groove radii are offset equal amounts on either side of the plane of the ball centers (Figure 26). In the Type X bearing the groove in each race has two radii whose centers are offset from the plane of the ball centers (Figure 27). The latter construction gives the Type X bearing its unique “Gothic Arch” configuration, making possible four contact points between a ball and the raceways.

Type X bearings are assembled by the methods described in Type C bearings, either Conrad or filling slot. With a filling slot, both the dynamic radial and thrust capabilities are impaired by the interruption of the ball contact path and speed of rotation must be limited.

The depth of groove in the Type X bearing is the same as in Types A and C (25% of ball diameter). The deep groove combined with the four-point contact geometry enables this bearing to resist a combination of radial, thrust, and moment loading. The manner in which the bearing accomplishes this is similar to that of a pair of Type A bearings duplexed back-to-back.

Referring to Figure 28, an axial force applied to the inner race from right to left is passed from the race to the ball at point B. It is then transmitted through the ball to point D where it passes into the outer race and support structure. The line of action BD forms a nominal 30° angle with the radial centerline of the bearing. Because of the elastic deformation of the ball and the race grooves along the load-transmission line, the ball load is relieved at points A and C permitting smooth rotation around an axis perpendicular to line BD. With an axial force applied to the inner race from left to right, a similar transmission of load occurs between points C and A.



### Moment or Overturning Load

A moment or overturning load is similar to two thrust loads acting in opposite directions at diametrically opposite sides of the bearing. With a moment load, the loading on one side of the bearing will pass from point B to D, relieving points A and C. Directly across the bearing, the load passes from point C to point A, relieving points B and D.

A radial load is resisted equally across the lines of contact CA and BD. Under combined loading the resistance is along both lines of contact with the magnitude of each reaction dependent upon the relationship of the individual loads.

By its ability to resist radial, thrust, and moment loads in any combination, the Type X bearing is often able to replace two bearings—a pair of angular contact ball bearings, a pair of tapered roller bearings, or a combination of thrust and radial bearings, either ball or roller.

As in the case of the Type C bearing, Type X bearings are normally supplied with diametral clearance. The latter bearing, however, is not dependent upon this clearance for its nominal contact angle and thrust capacity. On the contrary, where thrust or moment loading is considerable, the clearance should be minimized to prevent the angle of contact from becoming excessive. For many applications requiring greater stiffness, Type X bearings are furnished with an internal preload. This is accomplished by using balls larger in diameter than the space provided between the raceways. The balls and raceways in this case have some elastic deformation without the presence of external load.

**WARNING:** Type X Bearings are designed to be used singularly. Use of two Type X bearings on a common shaft could result in objectionable friction torque.



# Capacity, Life, and Load Analysis of Reali-Slim® Ball Bearings

The dynamic capacity values shown in this catalog are based on actual data from fatigue life testing. The capacities are based on 1,000,000 revolutions L10 fatigue life. This is the industry standard that was established for ease of calculation. It is not advisable to apply loads equal to the catalog capacities in an actual application. Loads of these magnitudes create contact stresses approaching the elastic limit of the bearing material. Continuous rotation under these conditions would not normally yield acceptable life.

L10 fatigue life is that life which 90% of a representative group of identical bearings can be expected to achieve or exceed before evidence of subsurface material fatigue appears. The life of the remaining 10% is unpredictable. The life which 50% of the bearings may be expected to achieve or exceed is approximately 5 times the L10 life. This is known as the L50 or median life.

There is no significant difference between the dynamic capacity for inner race rotation versus outer race rotation. This is due to the relatively small ratio of ball diameter to pitch diameter in Reali-Slim® bearings.

Static load capacities are shown in this catalog. However, the actual static load a Real-Slim bearing can withstand is dependent upon the amount of support provided by the shaft and housing. Please contact Kaydon whenever heavy static loads are anticipated.

## Life-Load-Speed Formulas

Since life, load, and speed of rotation are interrelated, this relationship must be considered when selecting bearings for various speed and life requirements. Based on extensive testing, bearing fatigue life has been determined to vary inversely with the third power of the applied load. This is expressed as follows:

**NOTE:** The following calculations assume pure radial or axial loads are applied. For combined loading, see discussion of Bearing Selection and Load Analysis. Refer to Kaydon's REALI-DESIGN™ computer software for capacity calculations or contact Kaydon product engineering.

$$(1) \quad L_r = \left(\frac{C}{P}\right)^3 \cdot 1,000,000$$

Where:  $L_r$  = L10 life in revolutions  
 $C$  = Kaydon dynamic rating  
 $*P$  = Applied load

For determining the life in hours at a given speed of rotation the above formula can be changed to read:

$$(2) \quad L_h = \left(\frac{C}{P}\right)^3 \cdot \left(\frac{16,667}{S}\right)$$

Where:  $L_h$  = L10 life in hours  
 $S$  = Speed in RPM

A further revision of the basic formula may be used to apply the catalog load rating for various conditions of speed and load:

$$(3) \quad P = C \cdot \left(\frac{500}{L_h}\right)^{1/3} \cdot \left(\frac{33.3}{S}\right)^{1/3} \quad \text{or} \quad P = CF_1F_s$$

Where:  $F_1 = \left(\frac{500}{L_h}\right)^{1/3}$  = Life factor

$F_s = \left(\frac{33.3}{S}\right)^{1/3}$  = Speed factor

To determine the required catalog capacity for given conditions of speed, load, and life the following formula may be used:

$$(4) \quad C = \frac{P}{F_1F_s}$$

\*In many applications the applied load  $P$  will be a mean effective load or equivalent load as described in the following paragraphs. This applied load should contain a factor of safety selected by the designer on the basis of knowledge of indeterminate loading, impact, vibration, etc.

### Mean Effective Load for Variable Loads and Speeds

In many applications, the speed of rotation and the applied load are variable and the effect of these variations on bearing life must be considered. For the effective load in these cases, the cubic mean of the various load conditions is determined. This mean effective load then becomes the applied load P in formulas (1) through (4).

When load alone is variable, the mean effective load may be found by the following formula:

$$P_m = \left( T_1 P_1^3 + T_2 P_2^3 + \dots + T_n P_n^3 \right)^{1/3}$$

Where:  $P_m$  = Mean effective load

$P_1, P_2, \dots, P_n$  = Variable load

$T_1, T_2, \dots, T_n$  = Percent of time (expressed as a decimal fraction) during which  $P_1, P_2, \dots, P_n$  are applied.

When speed varies with the load, the mean effective load is found by the formula:

$$P_m = \left( \frac{N_1 P_1^3 + N_2 P_2^3 + \dots + N_n P_n^3}{N_t} \right)^{1/3}$$

Where:  $N_1, N_2, \dots, N_n$  = Number of revolutions during which  $P_1, P_2, \dots, P_n$  are applied.

$N_t$  = Total revolutions of bearing

or by:

$$P_m = \left( \frac{T_1 S_1 P_1^3 + T_2 S_2 P_2^3 + \dots + T_n S_n P_n^3}{S_m} \right)^{1/3}$$

Where:  $S_1, S_2, \dots, S_n$  = Speed of rotation in RPM during time  $T_1, T_2, \dots, T_n$ .

$S_m = T_1 S_1 + T_2 S_2 + \dots + T_n S_n$  = Mean speed of rotation

### Equivalent Load Calculation for Combined Loading

In most applications, the external force or forces acting on a bearing mounting result in both radial and thrust (axial) loads on one or more of the bearings involved. To select a bearing on the basis of catalog load rating, it thus becomes necessary to determine an equivalent load to be used for the applied load P in formulas (1) through (4).

#### Type C Radial Contact

Where this bearing is properly applied, radial load should predominate and an equivalent radial load is determined by the formula:

$$P_r = F_r + 1.5 F_t$$

Where:  $P_r$  = Equivalent radial load

$F_r$  = Radial load

$F_t$  = Thrust load

#### Type A Angular Contact

In the discussion of bearing types, it was pointed out that angular contact bearings are commonly used in pairs, either adjacent or separated by spacers. In either case, the effect of combined loads can be best determined by a free-body analysis. Before proceeding with such analysis, however, a preliminary selection of bearing size may be determined by the following equivalent load formula:

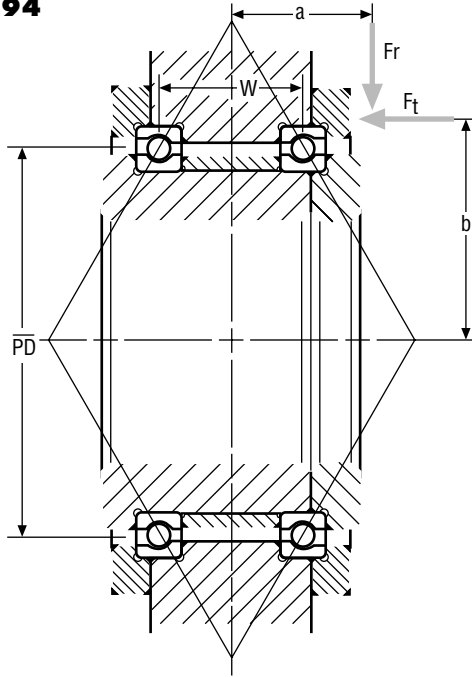
$$P_r = F_r + 0.9 F_t$$

Where:  $P_r$  = Equivalent radial load

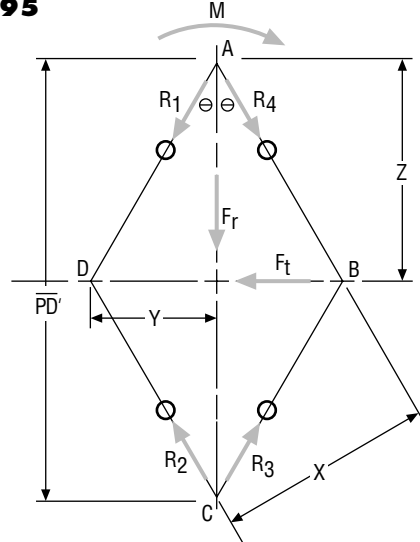
$F_r$  = Radial load per bearing

$F_t$  = Thrust load

**Figure 94**



**Figure 95**



$$\overline{PD}' = \overline{PD} + \frac{W}{\tan \Theta}$$

$$Z = \frac{\overline{PD}'}{2}$$

$$X = \overline{PD}' \sin \Theta$$

$$M = \text{Moment} = \pm F_r a \pm F_t b$$

$$Y = \frac{\overline{PD}' \sin \Theta}{2}$$

$$\Theta = \text{Contact Angle} = 30^\circ \text{ for Standard Bearing}$$

$R_1, R_2, R_3, \text{ \& } R_4 = \text{Bearing Reactions}$

Once a tentative bearing size is selected, the free-body calculation can be made.

Figure 94 shows a typical mounting of two angular contact bearings subject to external forces  $F_r$  and  $F_t$ . Figure 95 shows the equivalent force diagram including the net moment caused by the action of  $F_r$  and  $F_t$ .

In this analysis, the loaded races (usually the inners) are considered to constitute a free-body in space acted upon by the applied loads and stabilized through the ball contacts by the alternate races (usually the outers).

A plane is passed through the axis and the lines of action of the applied loads. For purposes of calculating the reactions  $R_1, R_2, R_3,$  and  $R_4$ , they are assumed to act only on the four balls whose centers are in the selected plane. Once the reactions are determined, the maximum reaction on each bearing is assumed to be distributed among the balls in that bearing in the same manner that a radial load would be distributed.

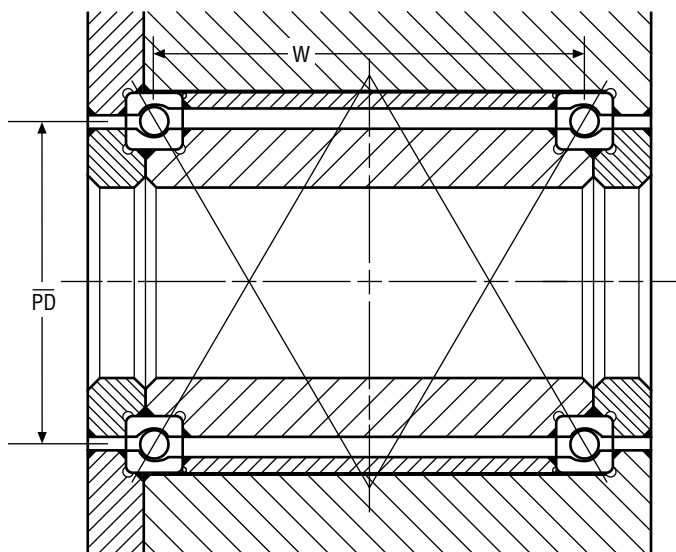
The maximum reaction can thus be converted to an equivalent radial load by the formula:

$$P_r = R_{\max} \cos \Theta$$

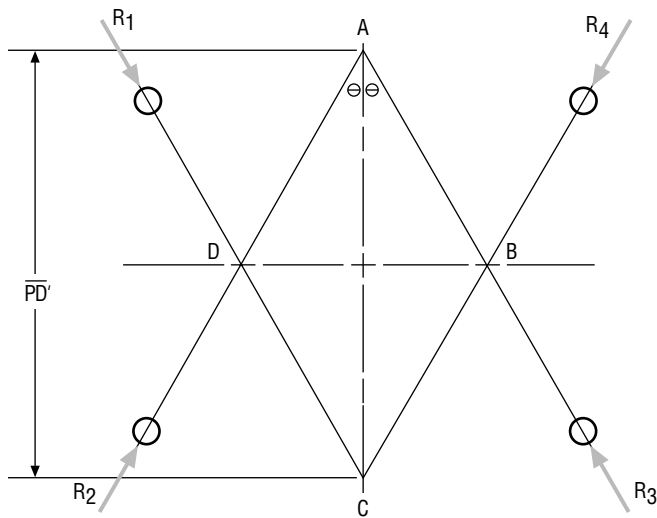
While four possible reactions are indicated, only three of these will occur due to bearing deflections under the applied forces. To solve for the reactions, one must be assumed equal to zero. The three remaining reactions are then determined by the summation of moments about points selected from A, B, C, and D. If one of the three calculated reactions is found to be negative, the original assumption of the inactive reaction is incorrect and a new assumption must be made.

The case illustrated here is for two bearings of the same pitch diameter mounted apart. A similar force diagram can be constructed for two bearings of unequal pitch diameter or for two identical bearings duplexed and adjacent. In the latter case, the bearing spread is approximately equal to the width of one bearing.

**Figure 96**



**Figure 97**



$$\overline{PD}' = \frac{W}{\tan \Theta} - \overline{PD} \text{ when } \frac{W}{\tan \Theta} > \overline{PD}$$

$$\overline{PD}' = \overline{PD} - \frac{W}{\tan \Theta} \text{ when } \overline{PD} > \frac{W}{\tan \Theta}$$

When angular contact bearings are used in the face-to-face arrangement with the lines of contact converging inside the bearings as in Figure 96, the force diagram appears as shown in Figure 97.

**Type X Four-Point Contact**

Since this bearing is capable of resisting radial, thrust, and moment loads, it is ordinarily subjected to a combination of two or more of these loads wherever it is applied. If used singly, in lieu of two angular contact (Type A) or two radial contact (Type C) bearings, it will usually have all three types of loading applied. If used in conjunction with a radial contact bearing, only thrust and radial loads are encountered. In either case, the effect of combined loads is best determined by a free-body analysis similar to that described for the angular contact bearings. Before proceeding with this analysis, a tentative bearing selection may be made by use of the following general formula for equivalent radial load:

$$P_r = \frac{1.2 M}{\overline{PD} \sin \Theta} + 0.75 F_r + 0.9 F_t$$

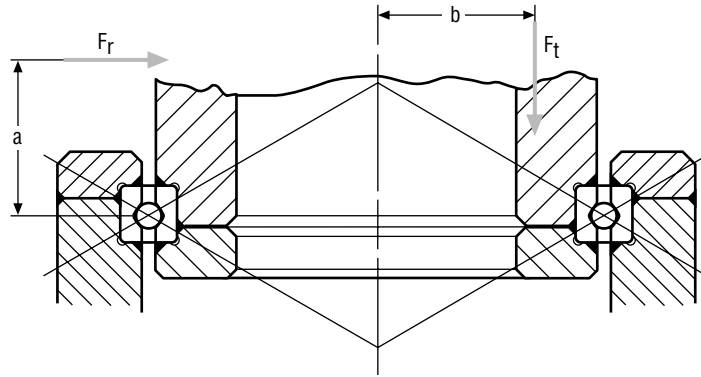
- Where:  $P_r$  = Equivalent radial load
- $F_r$  = Radial load
- $F_t$  = Thrust load
- $M$  = Moment load
- $\overline{PD}$  = Bearing pitch diameter in inches
- $\Theta$  = Bearing contact angle  
(30° for standard bearing)

When moment load is present, the known values,  $M$ ,  $F_r$ ,  $F_t$ , and  $\Theta$  (can be inserted in the formula to produce a relationship between  $P_r$  and  $\overline{PD}$ . Then by inspection and reference to the bearing tables, a bearing of sufficient  $\overline{PD}$  and cross section can be selected quite readily.

Once a tentative bearing selection has been determined, the free-body analysis can be made.

Figure 98 shows a four-point contact bearing subjected to radial and thrust forces which also induce a moment load. Figure 99 shows the equivalent force diagram including the moment.

**Figure 98**



To determine the bearing reactions and equivalent radial load, the procedure is identical to that described for the Type A angular contact bearing with:

$$P_r = R_{max.}$$

**Tapered Roller - KT Series**

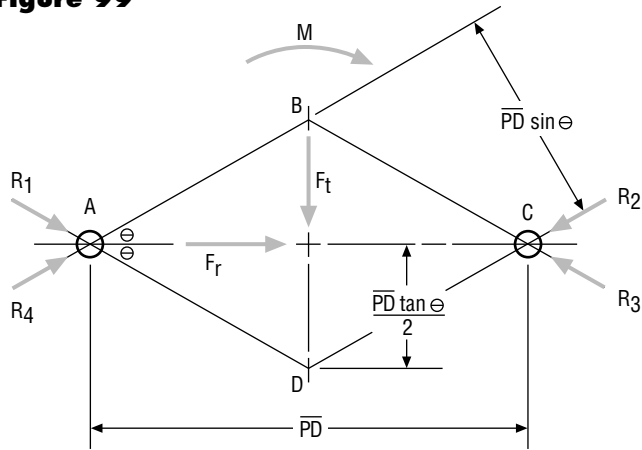
While the Reali-Slim® tapered roller bearing will accept both radial and thrust load, it is designed primarily for radial load. It is commonly employed in the same manner as the angular contact ball bearing (Type A) and can be selected for size by following the free-body load analysis for the latter bearing. In this analysis, a contact angle of 12° should be used.

For a preliminary selection, an equivalent load may be determined by the formula:

$$P_r = 0.67 F_r + 0.94 F_t$$

- Where:  $P_r$  = Equivalent radial load
- $F_r$  = Radial load per bearing
- $F_t$  = Thrust load

**Figure 99**



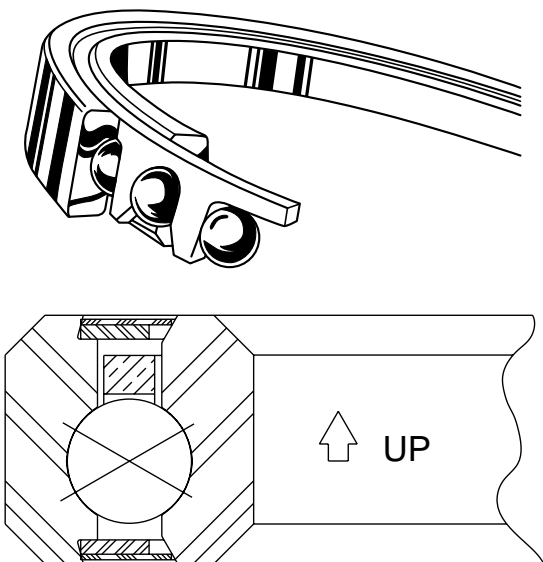


# Mounting

## ORIENTATION

It is suggested that in an application where the bearing axis will be within 45° of vertical, the bearing be positioned with separator pocket openings down or that a shoulder of the shaft or housing be extended as added assurance of retention. Sealed and shielded bearings have this position instruction etched on the O.D. by an arrow and the word “up” as shown below.

## Continuous Ring “Snapover Pocket” Separator



Correct bearing orientation is shown.

## Accuracy

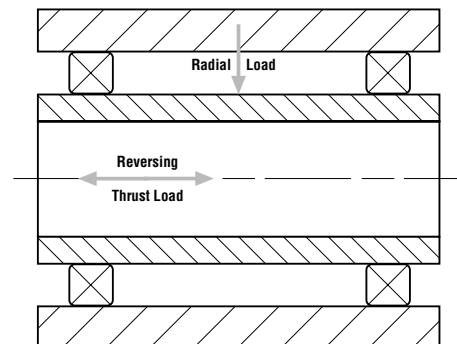
Three primary sources of displacement should be considered in a bearing application. These are looseness, deflection and geometric imperfections of the bearing and mating parts. Bearing imperfections consist of radial runout or eccentricity and axial or face runout. Corresponding to these, and of primary concern, are out-of-round and out-of-flat mounting surfaces of the mating parts.

Looseness can occur either between the bearing and the shaft and housing or within the bearing itself. In some applications, looseness cannot be tolerated, especially within the bearing.

Considering the load condition of Figure 29, it can be seen that with internal looseness (diametral clearance) in a Type C or Type X bearing, the thrust load will cause axial movement of the shaft relative to the housing. Because of its unique internal geometry with “built-in” contact angles, a Type X bearing exhibits much less axial movement (axial play) than a Type C

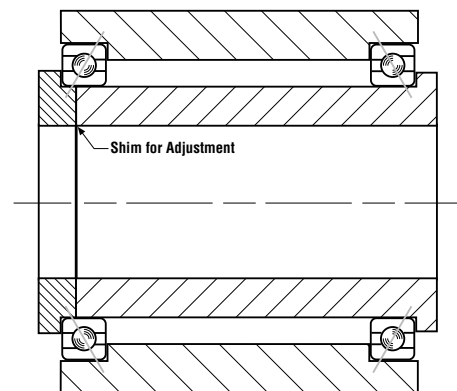
bearing of the same dimensions, having the same diametral clearance. So even though the thrust force is within the thrust capability of the Type C bearing, the Type X bearing is the better choice where control of axial movement is important.

**Figure 29**



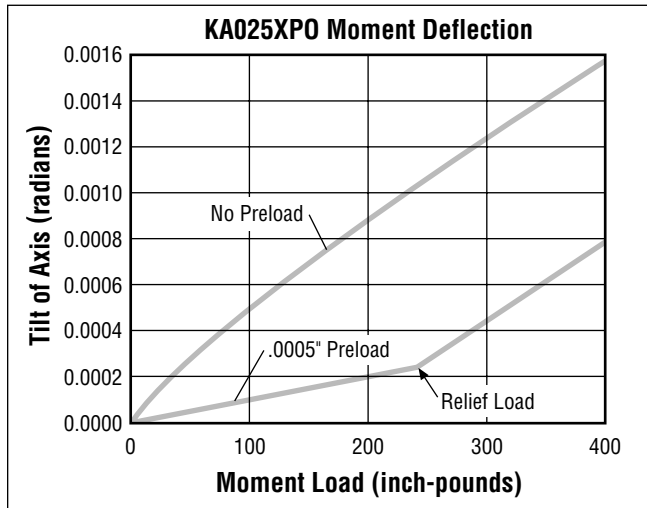
Where axial movement must be completely restricted, the Type X bearing can be preloaded by using balls of greater diameter than the space provided for them between the raceways. This is common practice and provides excellent control of axial play. Where speed is appreciable, however, preload is not acceptable in the Type X bearing due to increased friction and wear. The alternative, then, is to use the mounting of Figure 30 employing two Type A bearings. Their geometry is more tolerant of preload, and they offer the advantage of adjustment after installation, making it possible to remove clearance while minimizing preload.

**Figure 30**



Regarding bearing deflection, questions as to bearing spring rate (ratio of load to deflection) are common. To answer them, the nature and magnitude of the load must be considered. Since deflection can occur in three modes-axial, radial, and angular-corresponding to the three types of load, it follows that there are three types of spring rate. Moreover, deflection in a ball bearing is non-linear and thus the spring rate is not constant. Typical load vs. deflection curves are shown in Figure 31.

**Figure 31**



Computer generated reports to show the effect of shaft and housing fits are available for all Reali-Slim® standard bearings.

Deflection data for the three bearing types is shown on pages 74 thru 79.

In each series of Reali-Slim® bearings the ball to raceway conformity is the same for all three bearing types. Deflection under load varies from one type to another within a given series as a function of the contact angle and the number of balls. Conrad assembled bearings (C and X types) will exhibit greater deflection than those assembled by "loading notch" or a Type A bearing since C and X types have fewer balls. When two bearings are spaced apart to support a moment load, the space between the bearings is most important when considering angular deflection (tilt-of-axis).

Preloading is also a significant factor in reducing deflection, as shown in the load-deflection curve. In Figure 31 it can be seen that a deflection is non-linear for the non-preloaded bearing. In addition, the rate of deflection is higher for lower loads than higher loads. Deflection for the preloaded bearings is linear up to the point of preload relief. For loads that exceed the preload relief, the subsequent deflection follows the same slope as the non-preloaded curve but at a reduced rate.



Thus if preload is used, the deflection due to the work load will be markedly less whether preload is relieved or not.

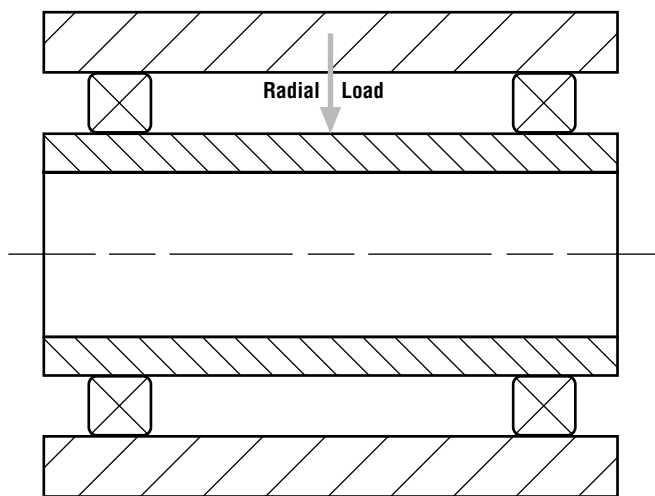
The Type A bearing is more tolerant of preload than is the Type X bearing. If maximum stiffness is required and speed of rotation is significant, Type A bearings are preferred.

Bearing precision, which influences accuracy, is independent of bearing type. Radial and axial runout, bore and O.D. tolerances, etc. are essentially the same for Types C, A, and X bearings of a given precision class.

## Load

With a pure radial load such as shown in Figure 32, it can be seen that the Type C bearings in Figure 34 would be ideal. They are designed for radial load, require no adjustment at installation, and are available in a wide variety of sizes. As shown, one bearing is fixed axially on both races and the other bearing is free to “float” in the housing. This arrangement permits differential expansion to occur between the shaft and housing without imposing axial loading on the bearings.

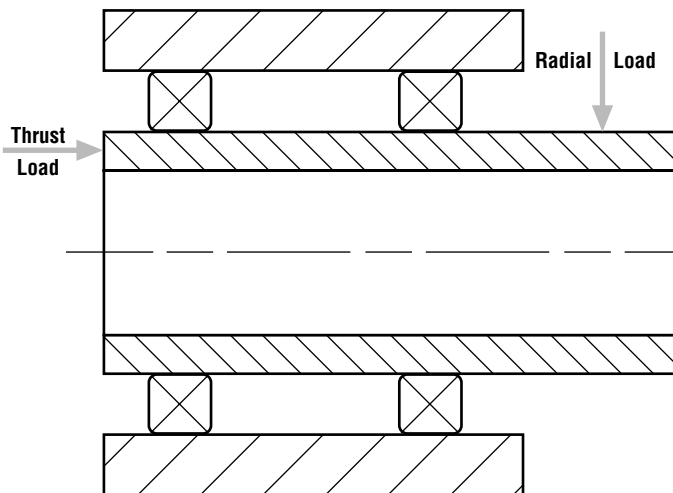
**Figure 32**



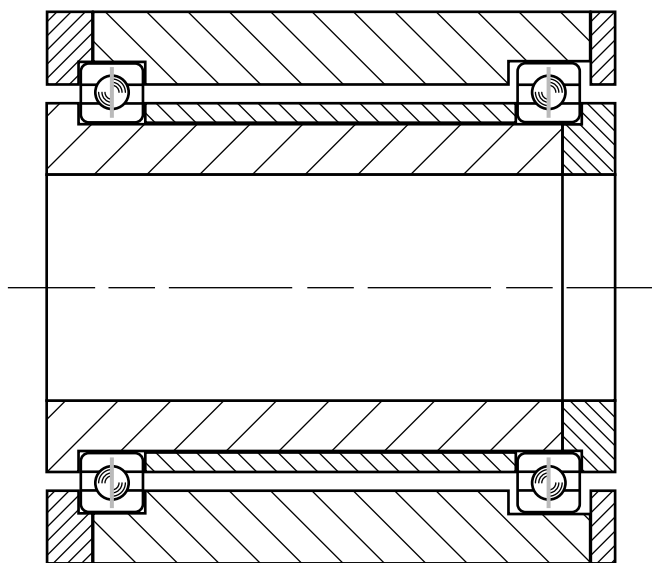
With an axial load applied as in Figure 29, consideration must be given to the thrust capability of the bearings. Type C bearings will accept some thrust loading, but where this loading is substantial, the Type X or Type A bearing is a better choice. The Type X bearing can be used with a Type C bearing as shown in Figure 35. This mounting is the same as that of Figure 34 except for the Type X bearing which is used at the “fixed” position to resist thrust in either direction while the Type C bearing “floats” and resists only radial load. With Type A bearings, the mounting could be as shown in Figure 37.

In the third load condition (Figure 33), the bearing arrangement in Figure 34 will be satisfactory for small thrust loads. Where thrust is significant, the arrangement of Figures 30, 35 and 36 should be considered. In the latter case, one Type X bearing will accommodate the combined loads while effecting savings in space, weight, and cost.

**Figure 33**



**Figure 34**

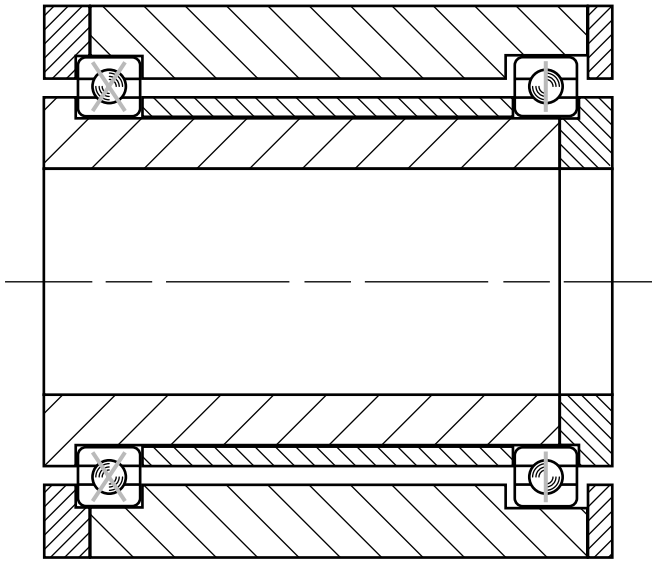


## Speed

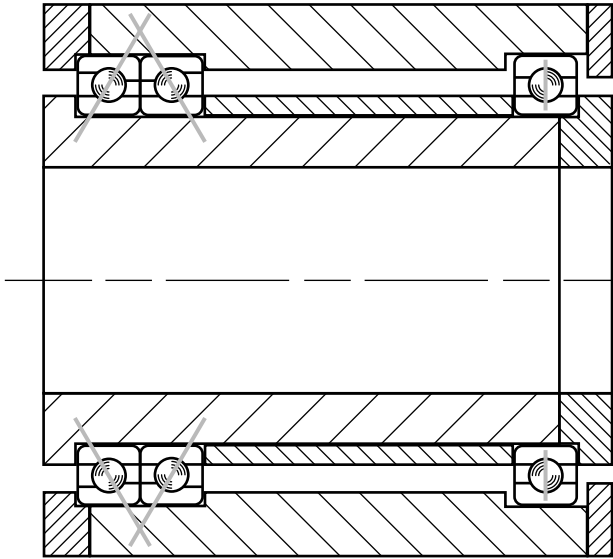
In bearing selection, speed of rotation is equally as important as loading.

Referring to Figure 29, arrangements of both Figure 30 and Figure 35 would satisfy the load conditions, but their suitability for high speed must be considered.

**Figure 35**



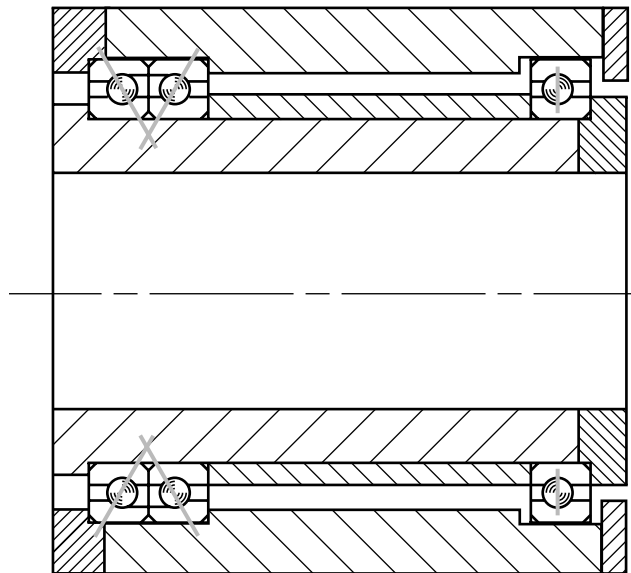
**Figure 37**



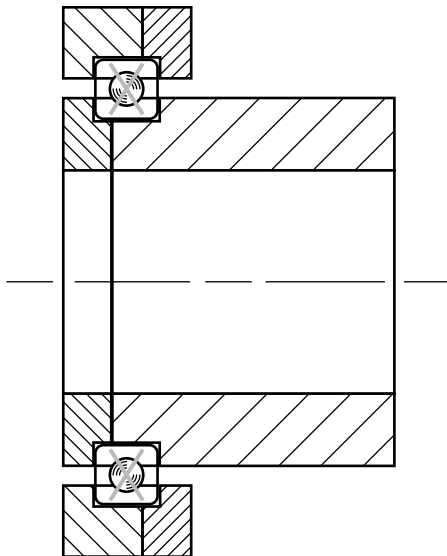
The better arrangement for high speed operation is that using Type A bearings (Figure 30), which can be adjusted to provide the optimum internal fit.

There is the possibility of differential expansion creating a problem when two Type A bearings a sizable distance apart are clamped against each other with all internal clearance removed. If this is the case, a "fixed-floating" arrangement can be used as shown in Figure 37 with a duplexed pair of Type A bearings at the "fixed" position and a Type C bearing at the "float" position. Another possibility is to spring load the Type A bearings of Figure 30.

**Figure 37A**

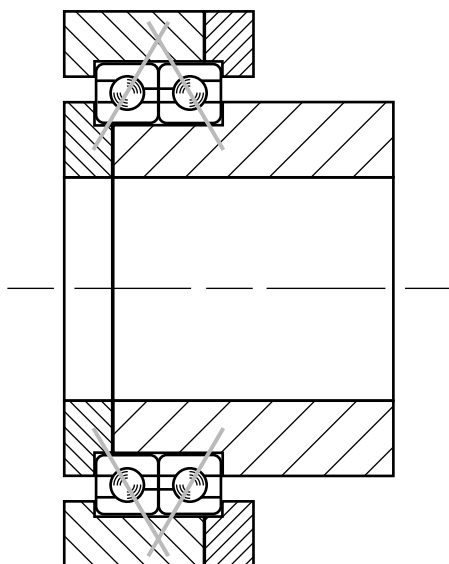


**Figure 36**



Where space is limited, combined loading exists, and speed is relatively high, a pair of Type A bearings as shown in Figure 38 would be given preference over the single Type X bearing of Figure 36. In this event preloading must be minimized. This can be accomplished by using a short spacer between the outer races and adjusting the bearings through the inner races.

**Figure 38**



Limiting speeds are given on page 68 and 69.

## Other Considerations

### Friction Torque

In applications where minimum driving force is a requirement, consideration should be given to friction torque. For low torque, preload should be avoided if possible. Type X bearings under combined loading can be expected to have more friction than Type A bearings. The separators, ball to raceway conformity, lubrication method, shaft and housing fits and temperature are among the factors influencing bearing friction. Awareness of a low torque requirement enables the bearing engineer to weigh the compatibility of these factors. Additional information on friction torque is on pages 70 and 71. Kaydon product engineering can provide estimates on friction torque, preload, mounting, temperature, and other criteria.

### Bearing Mounting

What materials are to be used for the shaft and housing? What range of operating temperatures will be encountered? Will there be a temperature differential between the shaft and housing? The

answers to these questions are necessary for proper bearing selection and application. Significant differential expansion will cause marked changes in both the external and internal bearing fits, especially in the case of the thin-section, Reali-Slim® bearings. These changes affect accuracy, friction, and bearing life.

Special attention must be given to bearing selection and application whenever conditions are different from those considered normal. For a normal application of standard Reali-Slim® bearings, the following apply:

### Arrangement

Type C and Type A bearings—Used with a second bearing with sufficient separation to resist moment loads. When the axis of rotation is within 45° of vertical, snapover separators should be positioned with pocket openings down or the shaft or housing should be extended as added assurance of separator retention.

All Types—Fixed races located axially by positive means. Snap rings used only for positioning and light loads. Shoulders, sleeves, or clamping rings used for heavy loads. No reliance upon interference fits for resistance to applied axial loads.

### Mounting

Shaft and housing of material with coefficient of thermal expansion of approximately .000007 inch per inch per degree F. Shaft and housing diameters round within bearing radial runout tolerances; shoulders flat within bearing axial runout tolerances; cross sections sufficiently rigid to provide good load distribution within bearing. Suitable sealing or shielding to protect bearing from contamination.

### Temperature

Means provided to maintain race temperature between -65°F and +250°F with no appreciable differential across the bearing.

### Lubrication

Standard bearings are shipped with preservative oil only. For best results, bearings should be flushed and lubricated with oil or grease suitable for speed and temperature conditions. See pages 83-84.

### Speed

Within limits of chart on pages 68 and 69.





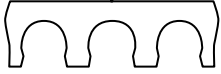
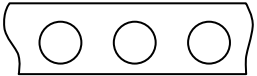
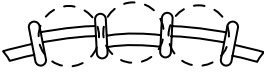
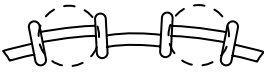





### Load

Within catalog rating after applying the recommended safety factor.

## **Section 4— Performance Considerations and Commercial Options Available**

- **Separator Types Available .....pgs.63-66**
- **Number of Balls in Standard Bearings ..... pg.67**
- **Optimizing Performance ..... pgs.68-79**
  - **Limiting Speeds**
  - **Torque**
  - **Axis Deviation**
  - **Deflection Curves**

# Overview of Reali-Slim® Bearing Separators

Code Letter*	Description	Design Features	Precautions	Material	Design
<b>P</b>	One piece formed ring with "snapover" pockets.	Standard ball complement. Used in Type C and X bearings for "KA" through "KG" cross-section bearings.	Commercial type cage, not recommended for low torque applications. Consult factory for temperatures below -65°F and above 250°F.	Brass or non-metallic composite.	
<b>R</b>	One piece formed ring with circular pockets.	Standard ball complement. Used in Type A bearings for "KA" through "KG" cross-section bearings.	Commercial type cage, not recommended for low torque applications. Consult factory for temperatures below -65°F and above 250°F.	Brass or non-metallic composite.	
<b>L</b>	One piece molded ring with "snapover" pockets.	Standard ball complement. Used in Type C and X KAA cross-section bearings.	Consult factory for temperatures below -65°F and above 250°F.	Nylon. Fiberglass reinforced.	
<b>G</b>	One piece molded ring with circular pockets.	Standard ball complement. Used in Type A KAA cross-section bearings.	Consult factory for temperatures below -65°F and above 250°F.	Nylon. Fiberglass reinforced.	
<b>D</b>	One piece machined ring with "snapover" pockets.	Standard ball complement. Used in Type C and X bearing when low torque, lightweight or vacuumed impregnation is required.	Not recommended above 250°F. Longer lead time and higher cost than "P" type separators.	Phenolic laminate.	
<b>H</b>	One piece machined ring with circular pockets.	Standard ball complement. Used in Type A bearing when low torque, lightweight or vacuumed impregnation is required.	Not recommended above 250°F. Longer lead time and higher cost than "R" type separators. Use toroid ball spacer when possible.	Phenolic laminate.	
<b>M</b>	Formed wire strip or segmental cage with "snapover" pockets.	Increased ball complement. Used in Type A, C, and X bearings for greater capacity (approx. 150%) and higher temperature.	Higher torque and lower speed capability than "R" type separators. Comparatively high wear rate. Requires loading notch for "C" and "X" bearings.	17-7 PH stainless steel	
<b>W</b>	Formed wire strip or segmental cage with "snapover" pockets.	Used in Type C and X bearings for high temperature applications. Standard ball complement.	Higher torque and lower speed capability than "R" type separators. Comparatively high wear rate.	17-7 PH stainless steel	
<b>F</b>	Full complement bearing.	Max. ball complement. Used in Type C, X, and A bearings for maximum capacity and stiffness.	High torque and low limiting speed due to ball rubbing. Not recommended for dynamic applications. Loading notches are required for "C" and "X" bearings.	Steel (Per ABMA Standard 10).	
<b>S</b>	Helical coil spring.	Reduced ball complement. Used in Type C and X bearings for low torque and high temperature.	Increased assembly cost. Should only be considered when PTFE spacer slugs cannot be used. Slow speed and light load only.	300 Series stainless steel.	
<b>Z</b>	Spacer slugs.	Standard ball complement. Used in Type C or X bearings for low torque. Prevents separator wind-up.	Not recommended for temperatures greater than 250°F or speeds in excess of 500 ft/min pitch line velocity. (Example: KA040CZ0 max speed = 450 rpm).	PTFE tubing	
<b>Z</b>	Toroid ball spacers.	Increased ball complement. Used in Type A bearings for low torque. Prevents separator wind-up.	Not recommended for speeds greater than 500 ft/min pitch line velocity. PTFE is limited to 250°F. Vespel® is limited to 500°F.	PTFE or Vespel® SP-1 polyamide plastic.	
<b>Z</b>	Spacer ball.	Requires a loading notch for C and X assembly. Low speed capability. Relatively high torque.	Increased ball complement. Used in Type A bearings for low torque. Prevents separator wind-up.	Steel per ABMA Standard 10. (Spacer balls are smaller than load carrying balls.)	

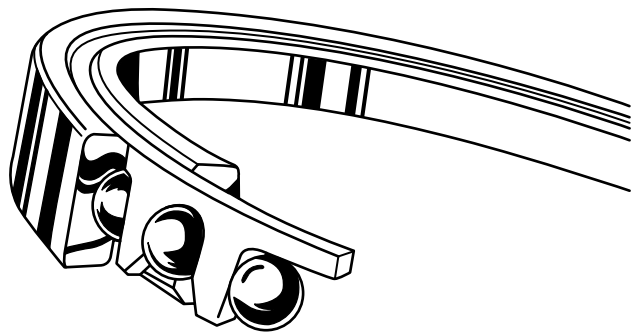
# Technical Specifics on Bearing Separators

The principal function of a bearing separator is to space the rolling elements uniformly, thereby preventing contact between them. Minute differentials in rolling element motion result from differences in individual rolling element loads and the inherent elasticity of bearing and mounting components. Without a separator some rolling elements will eventually contact each other. Due to the shape of the rolling elements and the opposite direction of motion of the contacting surfaces, a combination of relatively high contact stress and rapid motion is possible. Consequent abrasion of the rolling elements and residue of wear in the raceways affect life and torque characteristics, limiting the use of full complement bearings to slow speed applications where relatively large torque variations can be tolerated.

Kaydon separators for Reali-Slim® bearings are designated by a single letter character in coded part numbers (page 13), standard P, R, L, and G, separators have proved to be suitable for a wide range of operating conditions. Requirements, however, may dictate the use of different materials. This may affect capacities. Contact Kaydon product engineering. Operating temperatures for various separator materials are shown on page 63.

## Continuous Ring “Snapover Pocket” Separator

Figure 39



Designed for use in bearing types C and X, this style is installed after Conrad assembly of the races and balls. The tangs of the alternate “snap” pockets deform elastically to snap over the balls for retention of the separator. Centered on the balls at room temperature, the separator becomes outer race land riding or inner race land riding when temperatures cause differential thermal expansion or contraction.

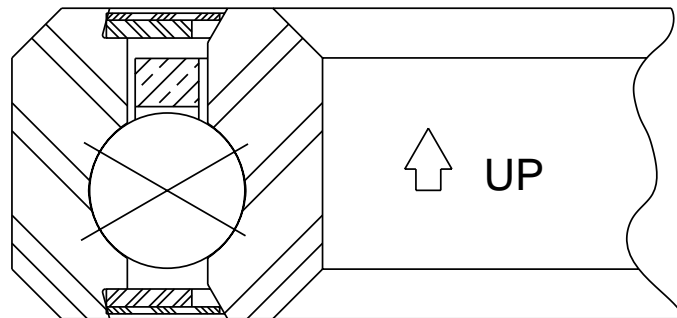
Close control of roundness and wall thickness insures effective piloting in either case, limiting separator “whip” and friction between the separator and race lands for smooth operation.

Standard materials used in this style are brass, non-metallic composite, and nylon reinforced with glass fibers. All have adequate strength, suitable friction characteristics and sufficient clearances for use in normal applications (as defined on Page 63).

Different materials are available for unusual operating conditions including stainless steel and non-metallics such as phenolic laminate, PTFE, and PEEK. Stainless steel separators are used in stainless steel bearings or high temperature applications for corrosion resistance. Phenolic laminate is used where light-weight and/or lubricant absorption is desired. The “snap-over” non-metallic separator is ideal for high speed applications of bearings too small in cross section for the two-piece riveted design (bearing Series C and lighter sections). It is also desirable in low speed, minimum torque applications.

### ORIENTATION

It is suggested that in an application where the bearing axis will be within 45° of vertical, the bearing be positioned with separator pocket openings down or that a shoulder of the shaft or housing be extended as added assurance of retention. Sealed and shielded bearings have this position instruction etched on the O.D. by an arrow and the word “up” as shown below.



Correct bearing orientation is shown.



## Continuous Ring Circular Separators

Figure 40

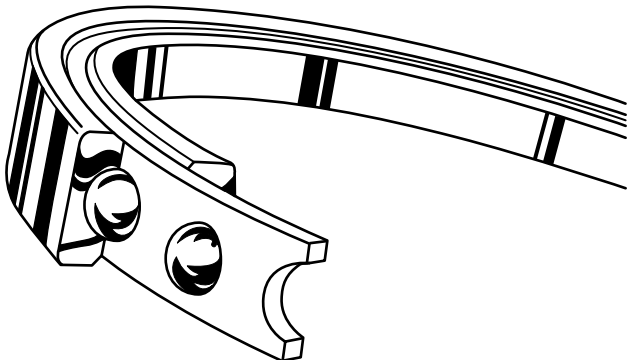
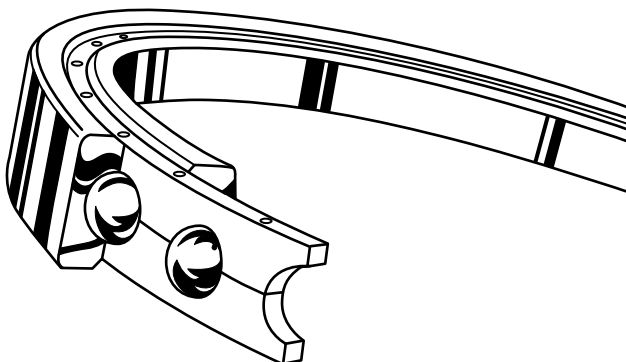


Figure 41



Designed for use in Type A bearings, the one-piece separator shown in Figure 40 is positioned around the inner race with the balls placed in pockets before the outer race is expanded thermally and dropped over the balls. This method of assembly permits the use of more balls than in the Conrad bearing Types C and X. In addition to the standard separators of brass, non-metallic composite and reinforced nylon, this style can be furnished in phenolic laminate, stainless steel, and aluminum.

Designed for use in non-standard bearings of Type C or Type X, the separator shown in Figure 41 is installed after Conrad assembly of the races and bearing and riveted together. Because of the space required for rivets, use is limited to Series D and heavier

sections. Usually machined all over, this style is recommended in phenolic laminate for very high speeds. Where very high strength is required, it is furnished in bronze, aluminum, or stainless steel.

As in the case of the continuous ring “snapover” pocket separator, both of these styles are centered on the balls at room temperature, becoming either outer race land riding or inner race land riding as the temperature changes.

## Segmental Separators

Segmental separators of either the ring or “snapover” design offer advantages for certain applications.

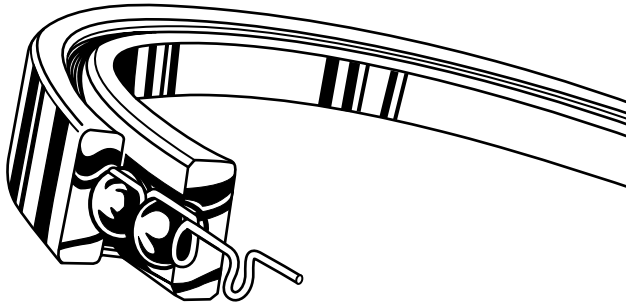
1. When larger diameter bearings are subjected to high temperatures, expansion differentials between the separator and the races may exceed the normal clearances provided.
2. When oscillatory motion, variable loading and a vertical axis combine to cause differential ball travel with no “vacation zone,” torque may become objectionably high or erratic.

A segmental separator may consist of a one piece open ring or it may be composed of two or more segments. Where differential expansion creates a problem, sufficient clearance is provided between the ends of the open ring or between the several segments to allow for this expansion. Where torque is of concern, the selection of the number of segments is made based upon experience. In all other respects, segmental separators satisfy the above descriptions for Continuous Ring “Snapover Pocket” Separators or Continuous Ring “Circular Pocket” Separators.

Segmenting the separator imposes somewhat greater restrictions on the bearings. Maximum allowable speed of rotation is reduced due to the centrifugal force energized “brake banding” of the segments against the outer race lands. Also, in the case of the “snapover pocket” style, a shaft or housing shoulder should be extended to assure retention of the separator irrespective of the operating position of the bearing. See next page.

### Formed Wire Separator

Figure 42



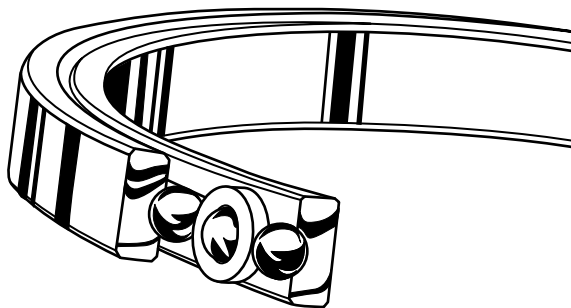
When the need exists for maximum capacity and thus the greatest possible number of balls, a formed wire separator may be used to avoid the disadvantages of a full complement bearing. It has been most successfully employed in Type A bearings, where the greater number of balls can be installed without resorting to use of a loading slot. Use in bearing Types C and X should be restricted to very low speed applications.

Comparatively high wear rate coupled with relatively light section can cause the wear life of the wire separator to be a limiting factor in the life a bearing, especially if the loads are high. However, where weight or space are at a premium and the added capacity is an important consideration, this separator may be considered a good compromise.

A bearing with a wire separator and maximum allowable ball complement has a static load capacity of 180% of the catalog static rating.

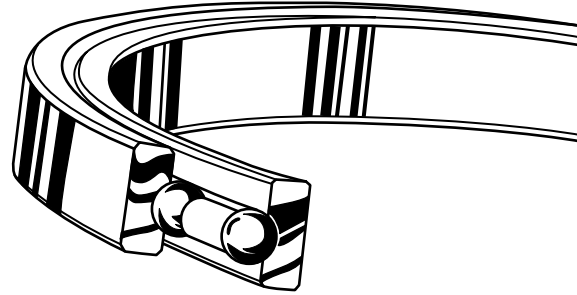
### Toroid Separators

Figure 43a



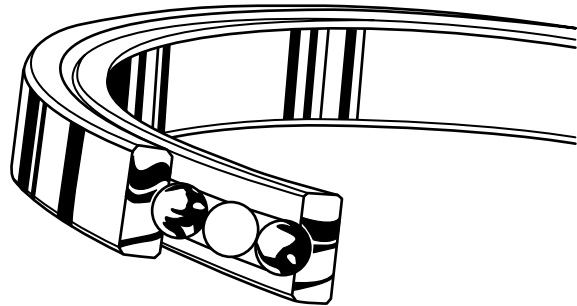
### PTFE Spacers

Figure 43b



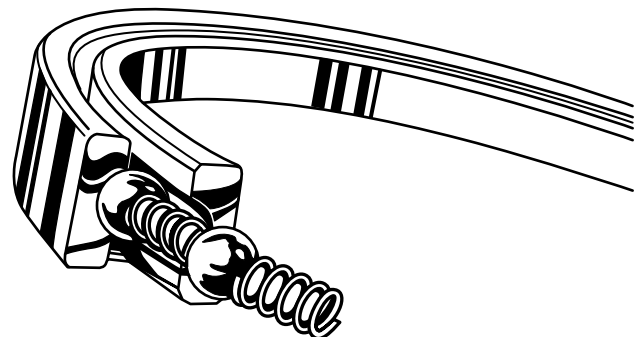
### Spacer Balls

Figure 43c



### Helical Spring Separators

Figure 43d



In some critical positioning applications, uniformity of torque is more important than the actual mean torque level. Specially designed toroids (Figure 43a), teflon spacers (Figure 43b), spacer balls (Figure 43c) or helical compression springs (Figure 43d) have proved in a number of such instances to be satisfactory for ball separation—by their nature they give a large amount of

individual and cumulative circumferential freedom to the balls. To prevent this freedom from being abused, however, speeds must be low and loads comparatively light.

Applications involving use of these separators should be referred to Kaydon for review and recommendation.

**Number of Balls in Standard REALI-SLIM® Bearings**

**Figure 44**

Brg. No.	Type A							Types C and X						
	KA A	KA	KB	KC	KD	KF	KG	KA A	KA	KB	KC	KD	KF	KG
10	28							21						
15	40							29						
17	44							33						
20		36	31						27	23				
25		44	38						33	28				
30		52	44						39	33				
35		60	51						45	38				
40		68	58	49	36	26	20		51	43	35	27	19	15
42		72	61	52	38	27	21		54	45	37	28	20	15
45		76	64	55	40	29	22		57	48	39	30	21	16
47		80	68	58	42	30	23		60	50	41	31	22	17
50		84	71	61	44	31	24		63	53	43	33	23	18
55		92	78	66	48	34	26		69	58	47	36	25	19
60		100	85	72	52	37	28		75	63	51	39	27	21
65		108	91	78	56	40	30		81	68	55	42	29	22
70		116	98	83	60	43	32		87	73	59	45	31	24
75		124	105	89	64	45	34		93	78	63	48	33	25
80		132	112	95	68	48	36		99	83	67	51	35	27
90		148	125	106	76	54	40		111	93	75	57	39	30
100		164	139	118	84	59	44		123	103	83	63	43	33
110		180	152	129	92	65	48		135	113	91	69	47	36
120		196	166	140	100	70	52		147	123	99	75	51	39
140			192	163	116	81	60			143	115	87	59	45
160			219	186	132	92	68			163	131	99	67	51
180			246	209	148	104	76			183	147	111	75	57
200			273	231	164	115	84			203	163	123	83	63
210												129		
220														69
250				288	204	142	104				203	153	103	78
300				345	244	170	124				243	183	123	93
350						198	144						143	108
400						226	164						163	123

# Limiting Speeds

Section 4--Performance Considerations

The determination of maximum safe operating speeds is largely empirical. A number of complex factors play a part in limiting the speed of rotation, some of which are:

- Bearing diameter
- Ratio of bearing diameter to cross-section
- Bearing type and internal configuration
- Ratio of ball groove radius to ball diameter
- Bearing internal fit-up (diametral clearance or preload)
- Operating contact angle(s)
- Bearing precision (runouts)
- Ball separator material and design
- Precision of mount (roundness, flatness under load)
- Lubrication
- Ambient temperature and provision for heat dissipation
- Seals
- Loads
- Life requirement

While precise speed limits cannot be set, experience in actual applications and in the Kaydon test laboratories can serve as a basis for setting general limits. Figure 47 takes into account some of the factors and assumes proper installation and adequate provision for heat dissipation. These limits are based upon achieving the full service life of 1,000,000 revolutions. If a shorter life is acceptable, higher speeds may be tolerated, except for bearings using formed wire and helical spring separators.

For speeds near or over the limits in the table, special attention must be given to lubrication and heat. Greases should be of types specially formulated for high speed bearings. Frequency of regreasing must be adequate to insure presence of lubricant at all times. If oil is used, viscous drag should be minimized by controlling the level, using slingers and/or metering small amounts as a liquid or mist. Windage effects at high speeds can make the introduction of oil to the critical surfaces very difficult, and the design of the lubrication system then becomes important.

Generally speaking, operating temperature will be limited by the allowable maximum temperature for the lubricant. If, however, bearing temperature is expected to exceed 250°F for extended periods, the bearings should be given stabilization treatment by Kaydon. This treatment will permit operation at temperatures up to 400°F.

While maximum temperature is important, consideration must also be given to possible temperature differential across the bearing. Generally, heat is lost through the housing at a higher rate than through the shaft. The housing fit and the bearing internal clearance before installation must be sufficient to allow for this as well as for the shaft fit if the necessary running clearance is to be realized.

## Examples of Limiting Speed Calculations

Example 1 (Standard Bearing)

Limited speed calculation for bearing part number KG040XP0.

Conditions: light thrust loads (<20%), grease lubrication.

From figure 45: slimness symbol = I

From figure 46: derating factor = 1.0

From figure 47: Type X; Separator P; Grease; Class 1; Charted figure = 9

$$\text{Calculation: } N = \frac{(1.0) (9) (1000)}{4} = 2,250$$

Example 2 (High Performance Bearing)

Limiting speed calculation for bearing number KD100AH6.

Conditions: loading at 25%, oil lubrication

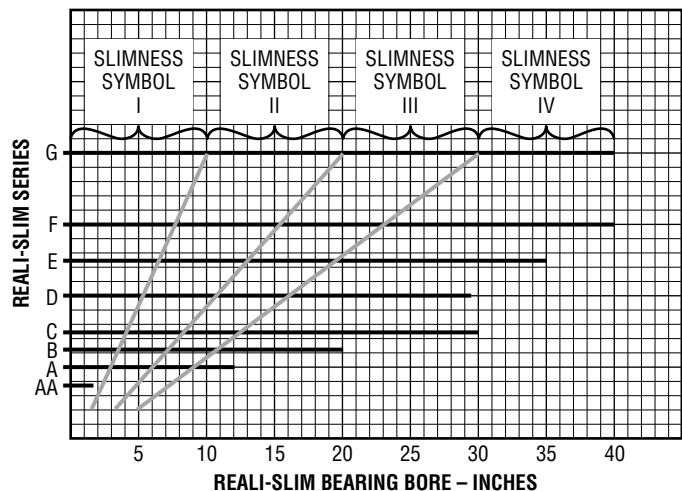
From figure 45: slimness symbol = II

From figure 46: derating factor = 0.9

From figure 47: Type A; Separator H; Oil; Class 6; Charted figure = 32

$$\text{Calculation: } N = \frac{(0.9) (32) (1000)}{10} = 2,880$$

**Figure 45 - Slimness Symbol (S<sub>s</sub>)**



**Limiting Speeds for Unsealed Lightly Loaded Reali-Slim® Ball Bearings**

$$\text{Limiting Speed (N)} = \frac{(F_1) (C_f) (1000)}{D}$$

where

D = Bearing bore in inches

N = RPM

**Figure 46 - Derating Factor (F<sub>1</sub>)**

For bearings loaded to following percent of dynamic rating	Multiply DN values by following factors
20	1.0
33	.9
50	.8
67	.7
100	.5
150	.2

**Figure 47 - Charted Figures (C<sub>f</sub>)**

Bearing Type	Load Conditions	Separator Type	PRECISION CLASS AND LUBRICATION																			
			CLASS 1, 3 & 4								CLASS 6											
			GREASE				OIL				GREASE				OIL				OIL MIST			
Slimness Symbol from Figure 45			I	II	III	IV	I	II	III	IV	I	II	III	IV	I	II	III	IV	I	II	III	IV
<b>C</b> with Diametral Clearance	Radial	P, L, X	15	12	9	6	21	18	15	12	21	18	15	12	27	24	21	18	30	27	24	21
		K	20	16	12	8	28	24	20	16	28	24	20	16	36	32	28	24	40	36	32	28
<b>A</b> Spring Loaded or Axially Adjusted	Radial and/or Thrust	R	15	12	9	6	21	18	15	12	21	18	15	12	27	24	21	18	30	27	24	21
		G, H	20	16	12	8	28	24	20	16	28	24	20	16	36	32	28	24	40	36	32	28
		M	8	6	5	3	11	9	8	6	11	9	8	6	14	12	11	9	15	14	12	11
<b>X</b> with Diametral Clearance	Thrust Only	P, L, X	9	8	7	6	11	10	9	8	11	10	9	8	14	12	11	9	15	14	12	11
	Radial Only or Combined Loading	P, L, X	3.0	2.5	2.0	1.5	4	3.5	3	2	4	3.5	3	2	4.5	4	3.5	3	5	4.5	4	3.5

**CONTACT KAYDON AT—**  
 Kaydon Corporation • Muskegon, Michigan 49443  
 Telephone: 231/755-3741 • Fax: 231/759-4102

**NEED SERVICE FAST?**  
 1-800-514-3066  
 Website: www.reali-slim.com

# Torque Considerations

Section 4—Performance Considerations

Torque, as it applies to bearings, is defined as the moment required to turn the rotating race with respect to the stationary race.

Usually the torque requirement of a ball bearing is only a small part of the demand of a mechanical system. In many Reali-Slim® bearing applications, however, masses and consequent inertias are slight and the amount of work being done is not great. In such cases, it may be important to know as accurately as possible how much turning effort must be provided.

Many factors contribute to the resistance to rotation of a lightly loaded anti-friction bearing, and most of this resistance comes from the more unpredictable ones—separator drag; viscous drag of the lubricant; minute deviations from true geometry in the balls, race ways, and mounting surfaces of bearing, shaft, and housing; internal fit-up of the bearing; and the presence of contaminants.

If it is a design goal to minimize available power required, Kaydon should be advised so that attention can be given to these factors. If necessary, the bearings can be furnished to a maximum torque level specification. In most cases, if proper attention is given to the lubricant, the shaft and housing mounting surfaces, and bearing cleanliness, the torque level of standard bearings will be satisfactory.

In the selection of the lubricant and lubricating system, their effects on torque should be kept in mind. To be considered are operating temperatures; speeds of rotation; type, viscosity and quantity of lubricant. All are major factors in determining lubricant drag.

In tolerancing the shaft and housing it is important to set limits for out-of-roundness and out-of-flatness of the bearing seats. For normal requirements a good rule of thumb is to use the bearing radial and axial runout tolerances as the respective limits. For critical torque applications, closer tolerances should be specified since even a very small amount of localized internal preload (negative clearance) will create surprisingly large ball loads and consequent high torque. Where torque must be minimized it is important to limit out-of-roundness of housing or shaft to values which will insure against complete loss of internal clearance.

Cleanliness is extremely important in maintaining uniformity of torque as well as a low level of torque. Very small amounts of microscopic particles of lint, dust, and other common contaminants can cause bearing torque to vary several hundred percent in just a few degrees of rotation. For this reason bearings should be kept in their original unopened package until time for installation. Every effort should be made to protect them from foreign matter, whether or not torque is critical.

The accompanying charts show approximate torque levels of Reali-Slim® bearings under common conditions. Estimates can be furnished for more unusual situations. Information submitted should contain all operating conditions of load, speed, lubricant, and environment including temperature together with a print of the intended mounting, showing materials and radial sections. If a limit has been set on permissible system error in terms of axis deviation—radial translation, axial translation, or angular rotation (page 72)—this information should also be submitted.

## Q SERIES

This series of bearings uses standard materials but additional processing to achieve the lowest possible torque levels. High precision races and balls, super-finished ball tracks, and precisely set internal fit-ups assure optimum performance. As low operational torque is the key feature of this series, it is only offered in angular contact bearings arranged in either DB or DF sets.

- Low torque ball separators
- White room cleaning
- Factory-lubricated bearings
- ABMA Grade 10 balls
- Super finish ball track

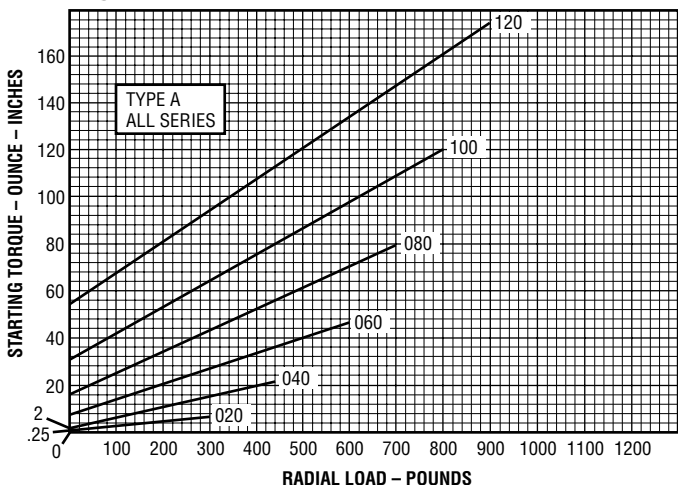
## Materials

Races	AISI 52100 (Precision Class 6)
Balls	AISI 52100 (Grade 10)
Cage	PTFE or Vespel® toroid ball spacers

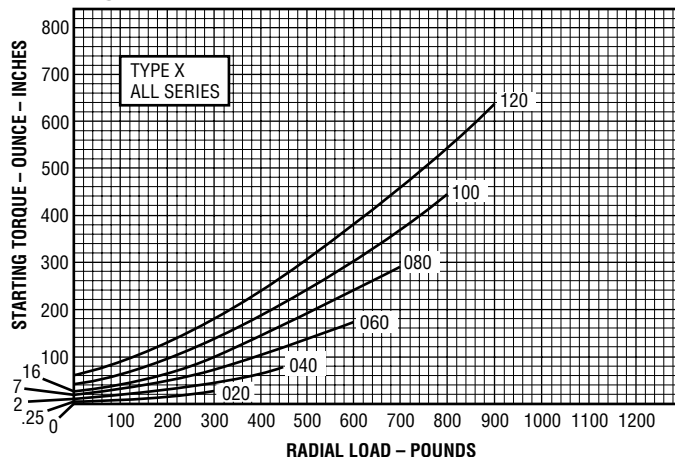
# Starting Torque vs. Load

Computer generated torque curves for mounted Reali-Slim® bearings can be provided by Kaydon Product Engineering

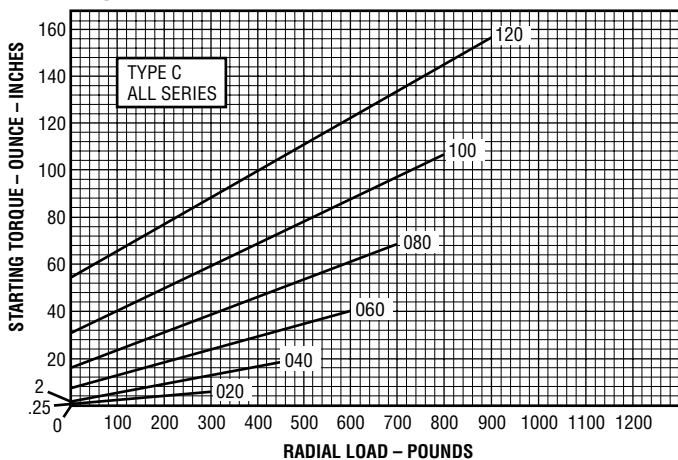
**Figure 48**



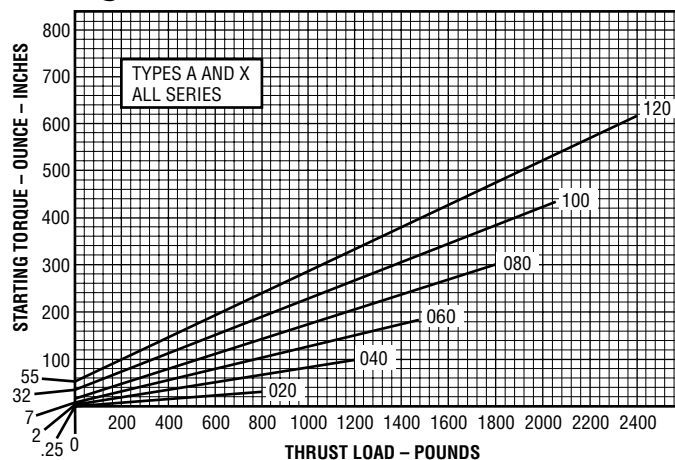
**Figure 50**



**Figure 49**



**Figure 51**



## Notes Applying To These Charts

1. Values shown are T10 ratings\* based on:

- Kaydon Precision Class 1 bearings with some internal clearance remaining after installation
- A rigid mounting, round and flat within respective radial and axial bearing runout limits
- Light oil lubrication
- Room temperature

2. Running torque at speeds up to 10 RPM usually averages from 25 to 50% of starting torque, and increases with increasing speed to as much as 200% at maximum allowable diametral clearance (page 73).
3. Interpolate for intermediate sizes.
4. Curve number indicates bearing bore in tenths of an inch.

\*Usually not more than 10% of a group of bearings will have torque demands higher than those shown.

# Bearing Axis Deviation Due To Clearance And Deflection

Reali-Slim® bearings are often used in applications where the position of a rotating part relative to the stationary structure is critical. Knowledge of the displacement of the axis of rotation and the factors contributing to it are thus important.

The axis of rotation can be displaced from its true position in three ways—radially, axially, and angularly. These deviations are referred to as radial translation, axial translation, and tilt (angular rotation) respectively.

In addition to the obvious effects of bearing runout, total deviation of bearing axis in any one of the above conditions is due to the effects of bearing diametral clearance and elastic deflection (deformation) at the ball or roller contacts. The diametral clearance after installation changes due to the combined effects of external fitting practice, differential thermal expansion or contraction of the bearing races and mounting structures, and relative rigidity of the races and mating parts.

Elastic deflection at the ball or roller contacts results from the externally applied bearing loads and is influenced by ball or roller diameter, race groove radius, raceway diameters, and contact angle.

The following three equations are given to aid in determining displacement. The internal diametral clearance (DC) must be calculated or approximated. The remaining independent variables can be obtained from the graphs on pages 74 thru 79.

$$RT = RD + \frac{DC}{2}$$

$$AT = AD + \frac{AC}{2}$$

$$AR = MD + AC/PD$$

Where:

RT = Radial Translation – in inches

AT = Axial Translation – in inches

AR = Angular Rotation – in inches/inch or radians

RD = Radial deflection due to radial load – in inches

AD = Axial deflection due to axial load – in inches

MD = Moment deflection due to moment load – in inches/inch or radians

DC = Diametral clearance – in inches

AC = Axial clearance – in inches

PD = Pitch diameter  $\frac{O.D. + Bore}{2}$  – in inches

The equations may be used in applications where the radial, axial, or moment load is applied singly or where one type of loading predominates. Applications subjected to combined loading in which more than one type is significant should be referred to Kaydon for analysis.

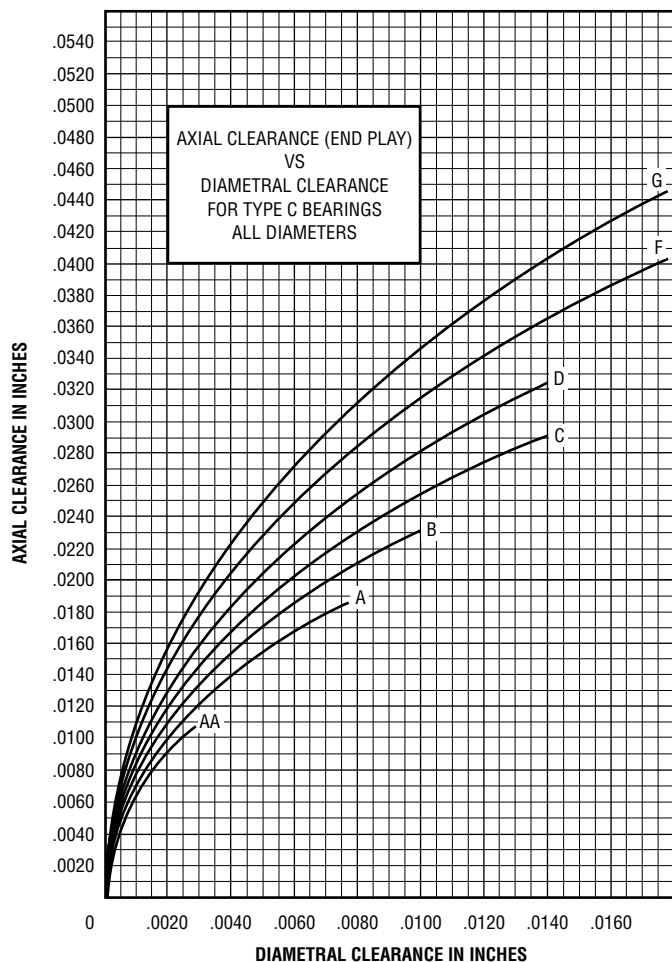
**Computer generated reports and graphs for Reali-Slim® bearings are available from Kaydon engineering and from our Reali-Design™ computer software.**

Section 4—Performance Considerations

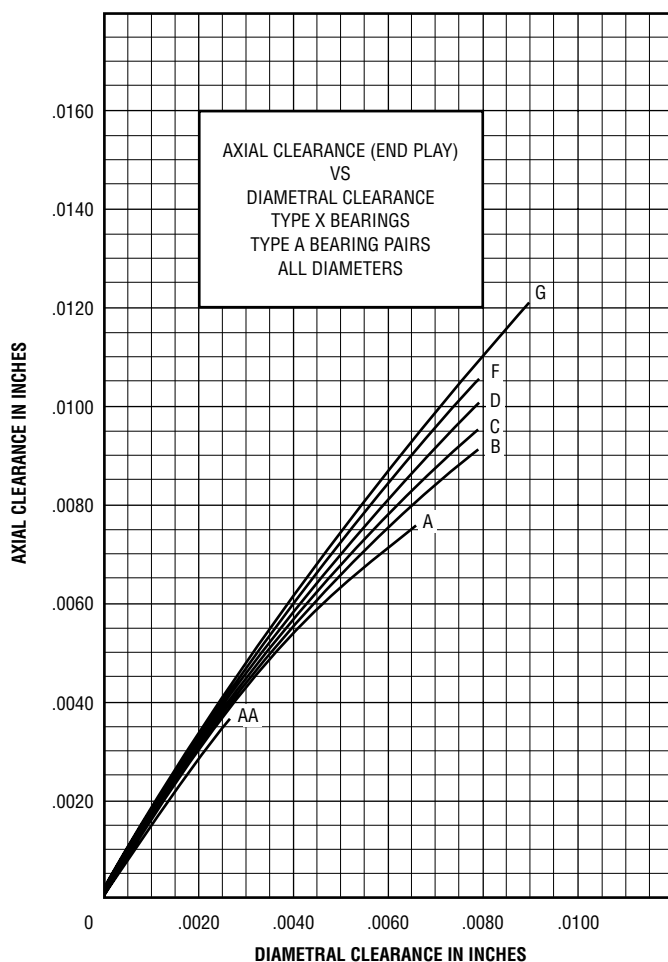


# Axial Clearance vs. Diametral Clearance

**Figure 52**



**Figure 53**



Section 4 - Performance Considerations

**CONTACT KAYDON AT—**  
 Kaydon Corporation • Muskegon, Michigan 49443  
 Telephone: 231/755-3741 • Fax: 231/759-4102

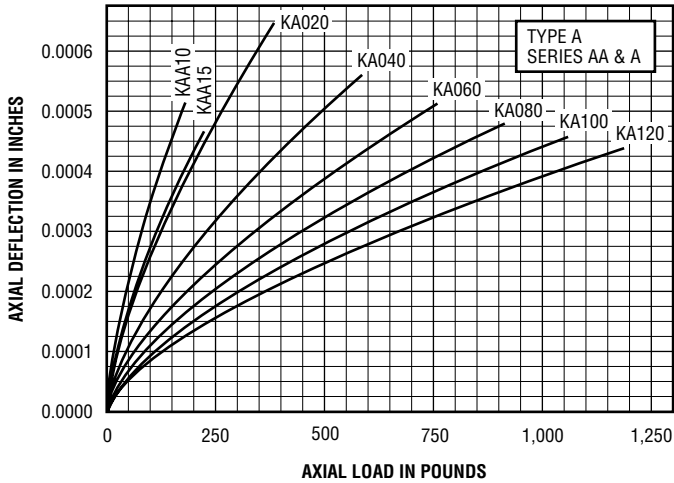
**NEED SERVICE FAST?**  
 1-800-514-3066  
 Website: www.reali-slim.com

# Axial Deflection vs. Axial Load

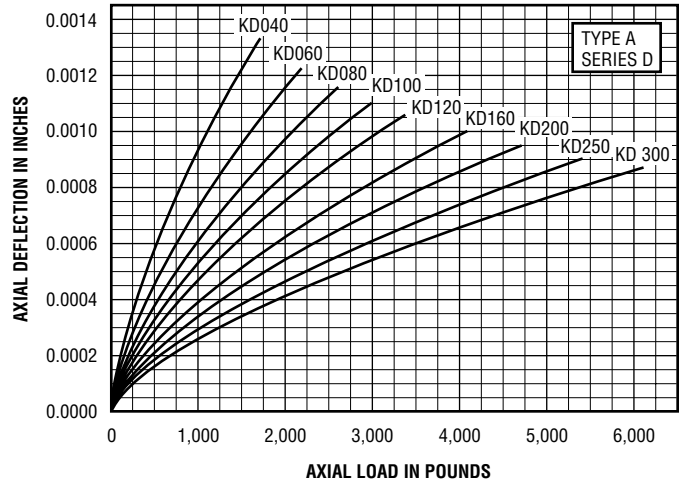
## Type A Angular Contact

Computer generated stiffness reports and graphs are available for all Reali-Slim® bearings for mounted and unmounted conditions.

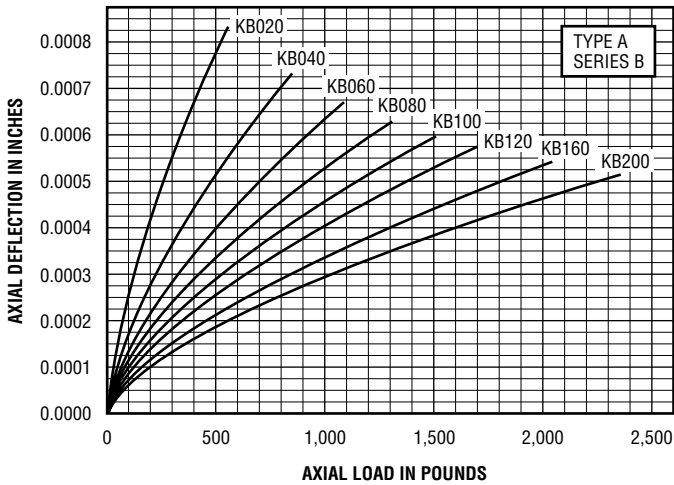
**Figure 54**



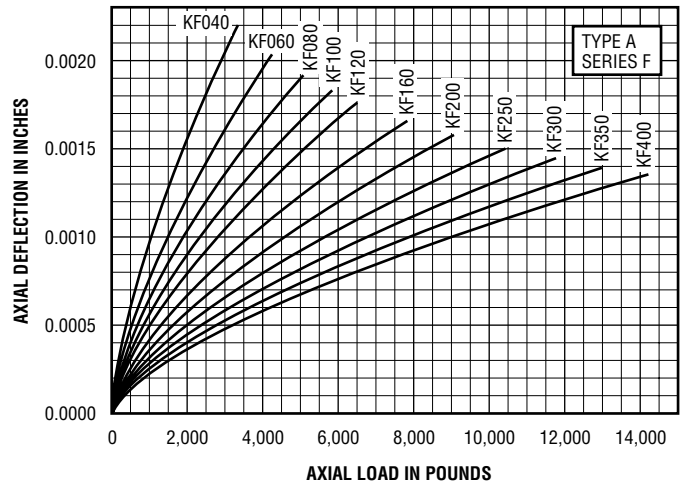
**Figure 57**



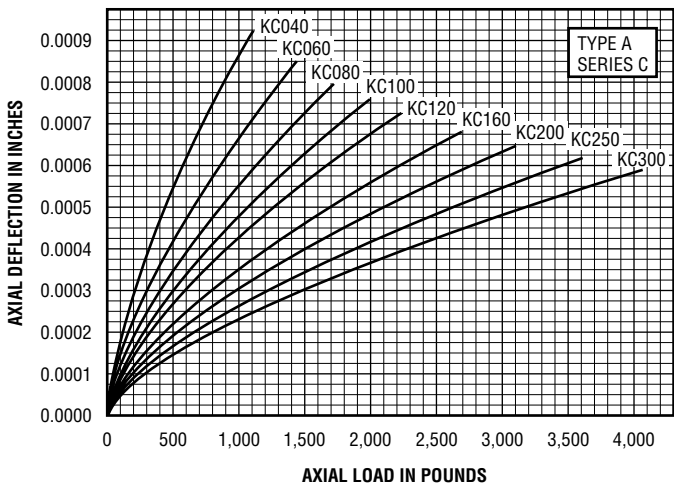
**Figure 55**



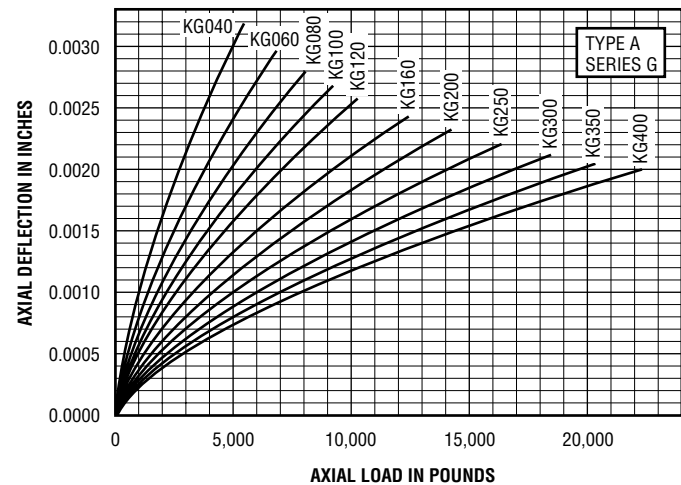
**Figure 58**



**Figure 56**



**Figure 59**

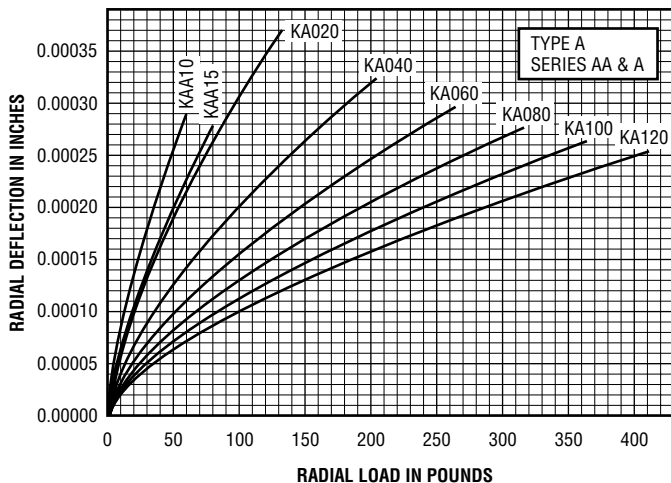


Section 4--Performance Considerations

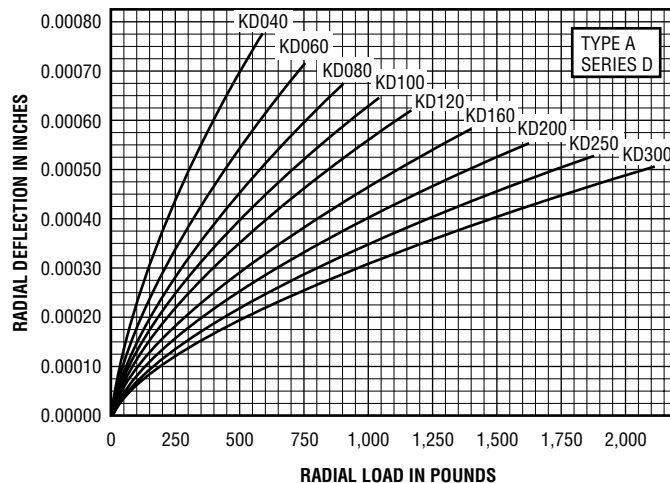
# Radial Deflection vs. Radial Load

## Type A Angular Contact

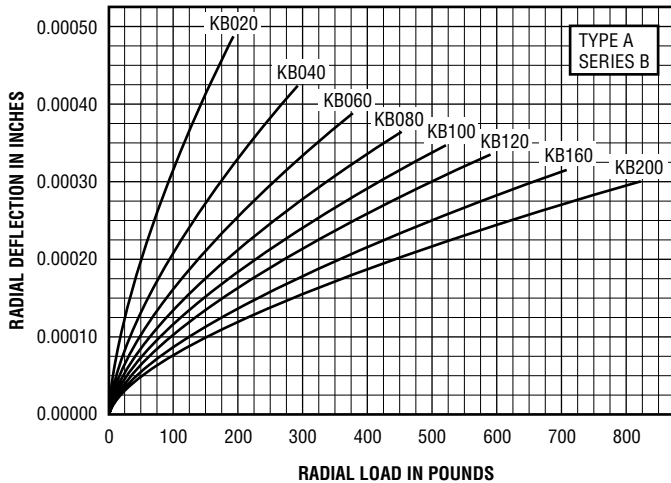
**Figure 60**



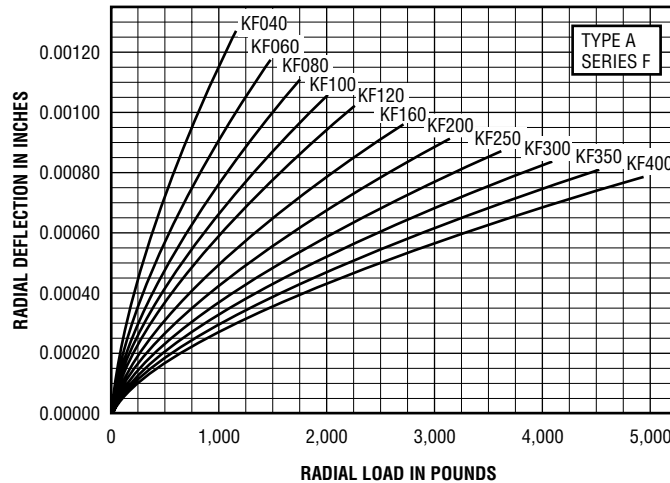
**Figure 63**



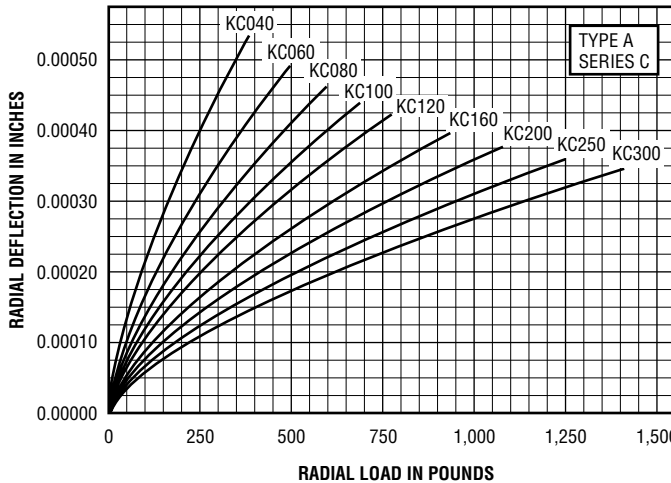
**Figure 61**



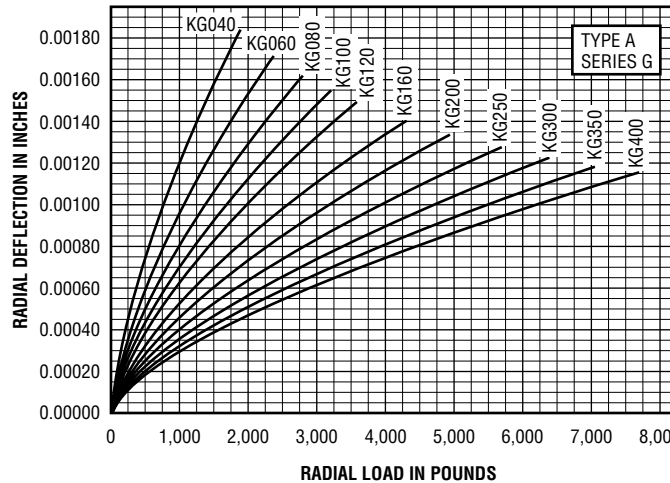
**Figure 64**



**Figure 62**



**Figure 65**

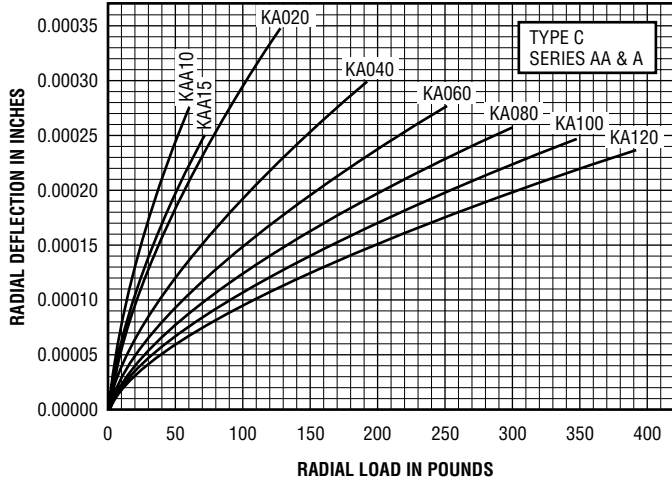


Section 4 - Performance Considerations

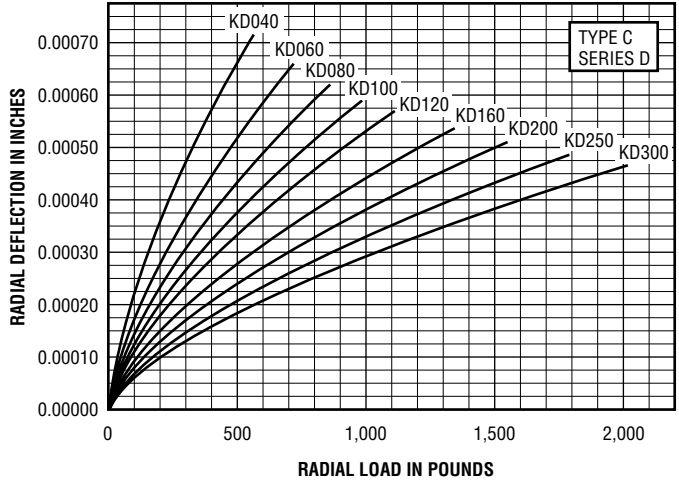
# Radial Deflection vs. Radial Load

## Type C Radial Contact

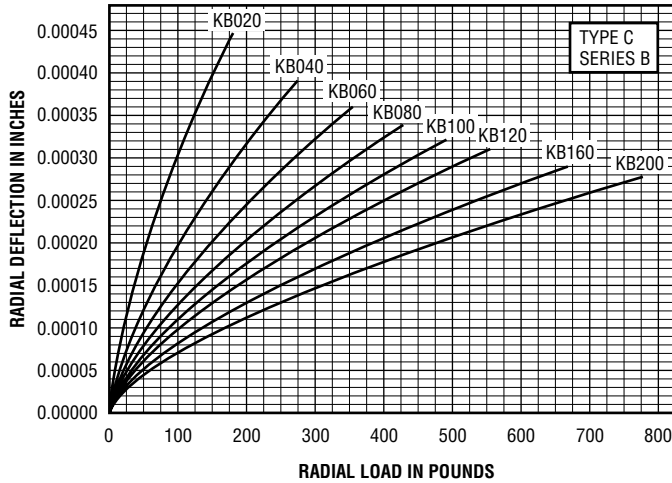
**Figure 66**



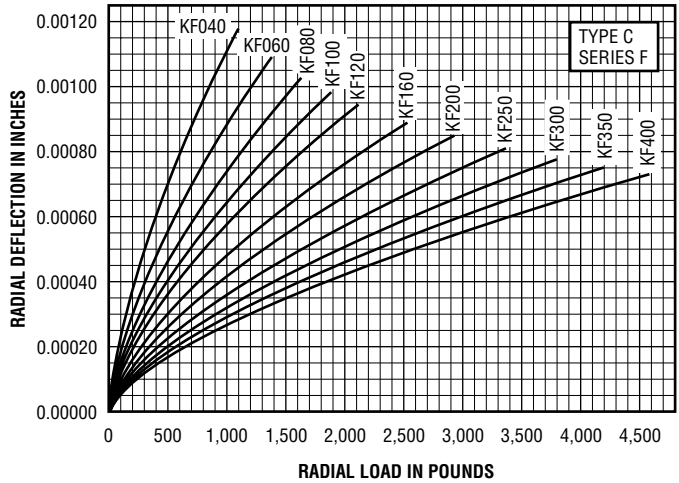
**Figure 69**



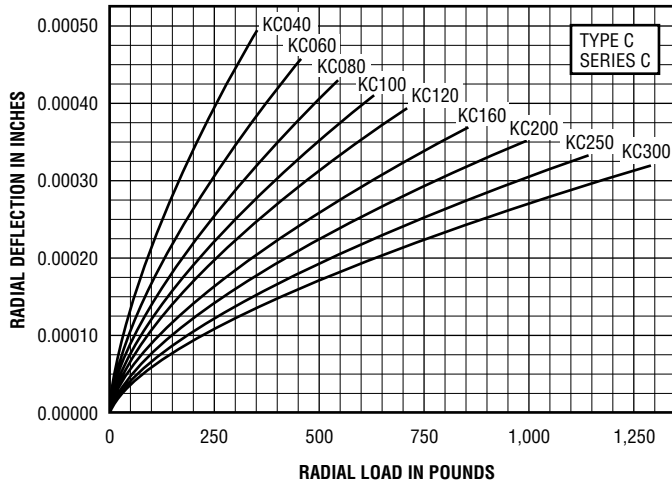
**Figure 67**



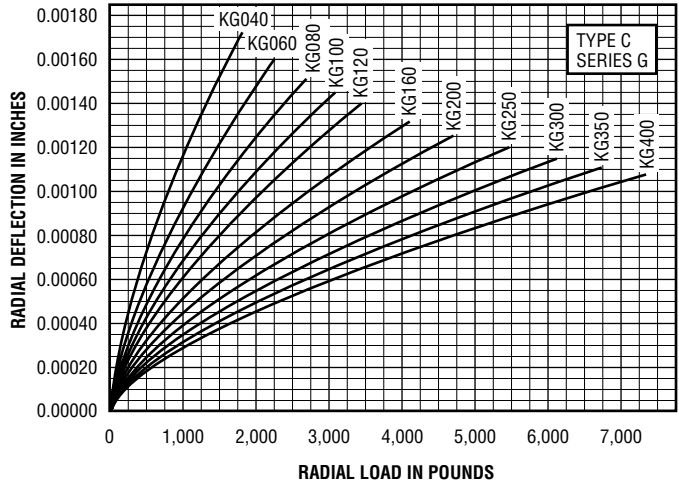
**Figure 70**



**Figure 68**



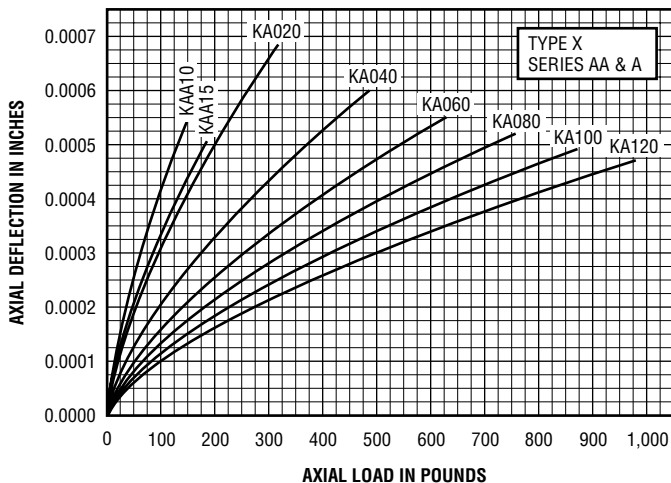
**Figure 71**



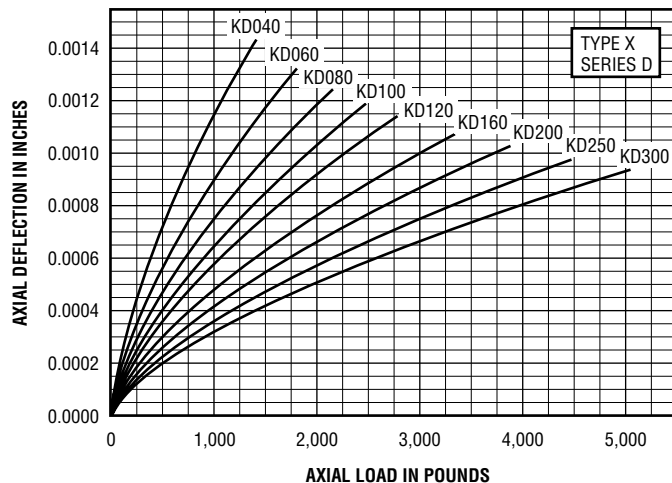
# Axial Deflection vs. Axial Load

## Type X Four-Point Contact

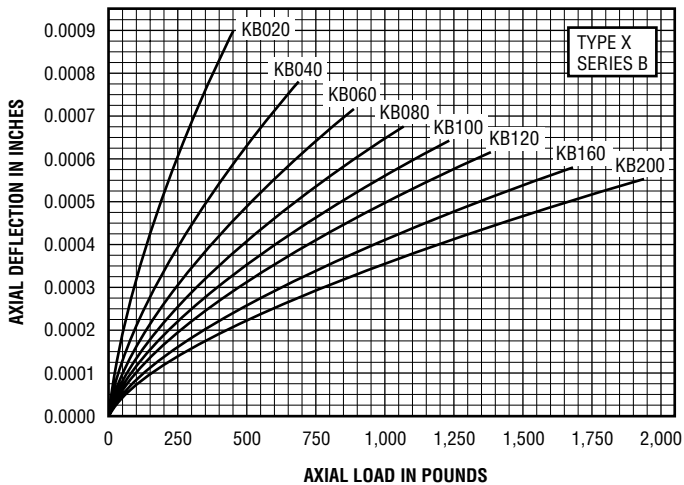
**Figure 72**



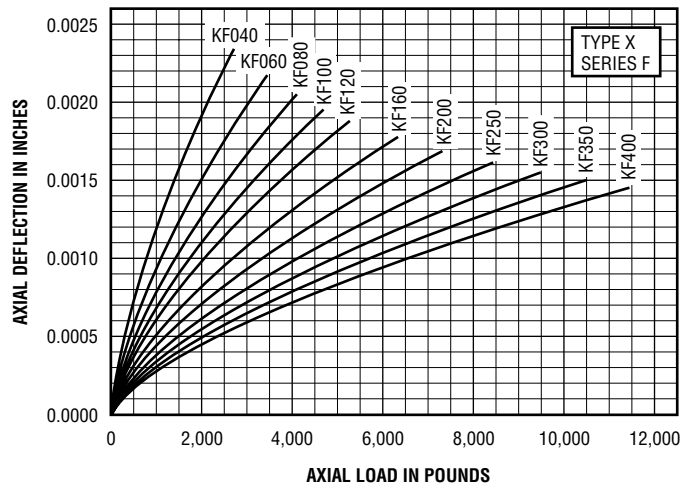
**Figure 75**



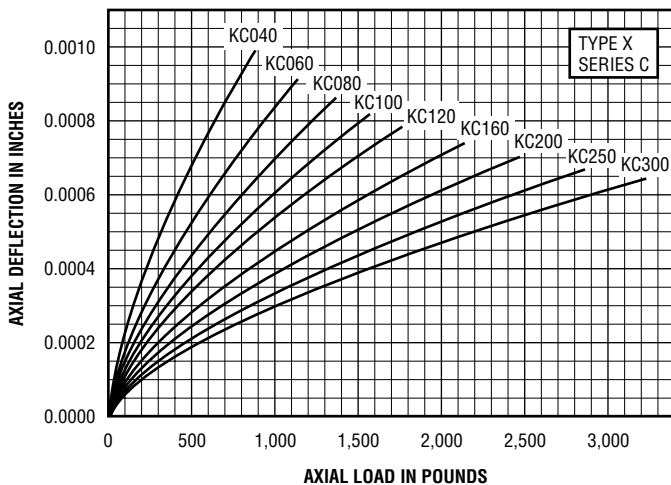
**Figure 73**



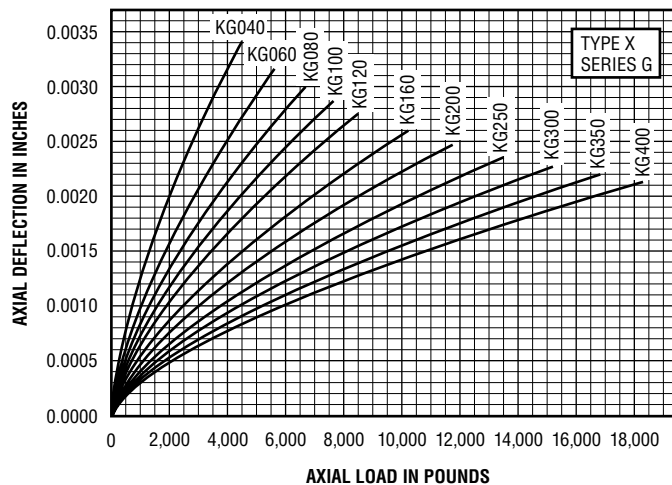
**Figure 76**



**Figure 74**

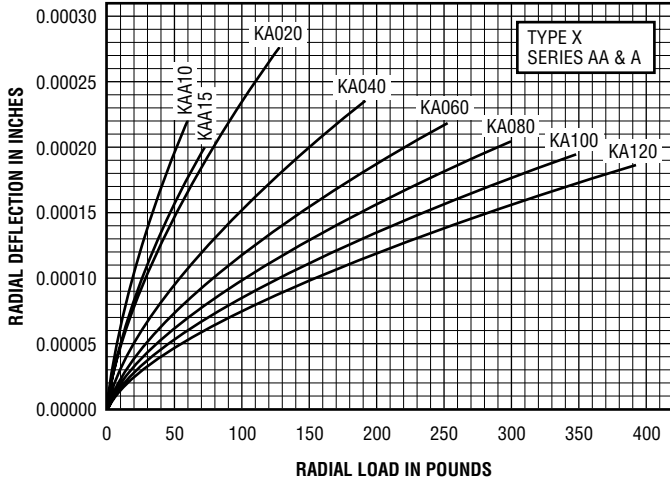


**Figure 77**

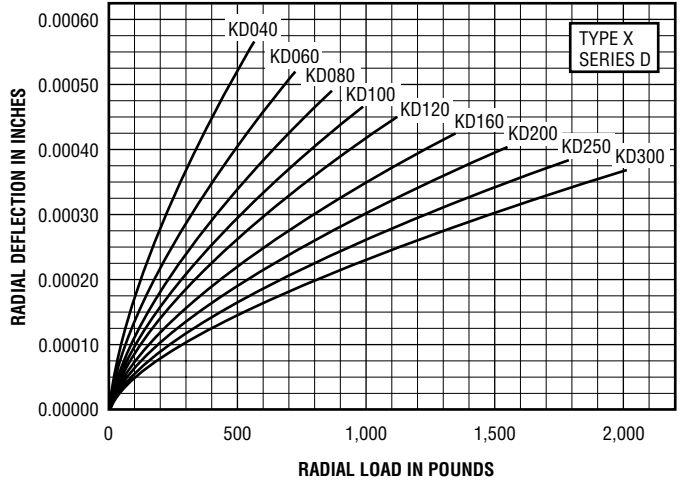


Section 4 - Performance Considerations

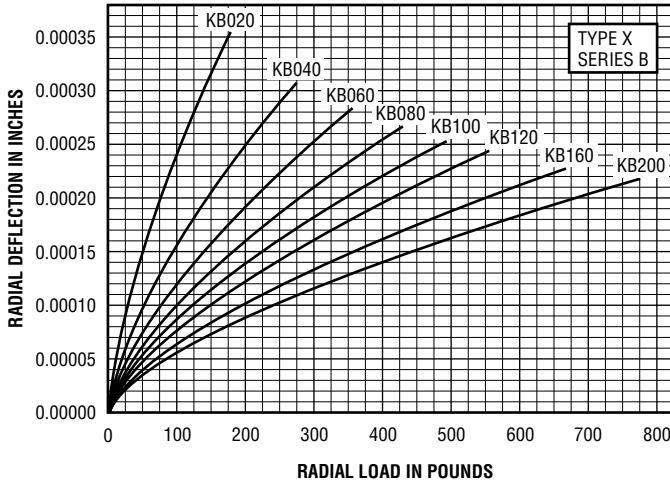
**Figure 78**



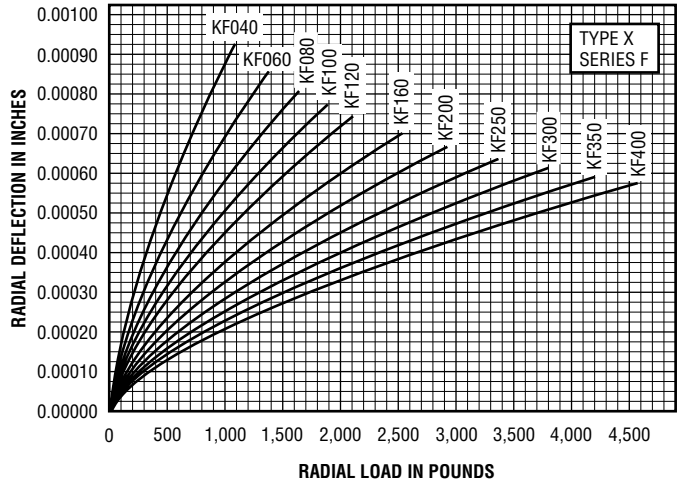
**Figure 81**



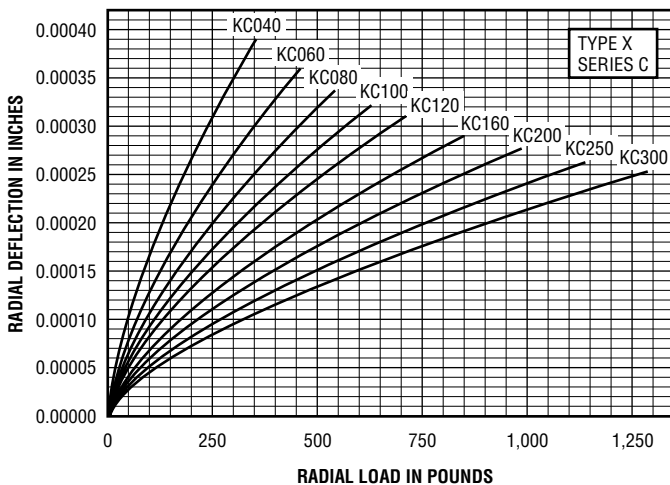
**Figure 79**



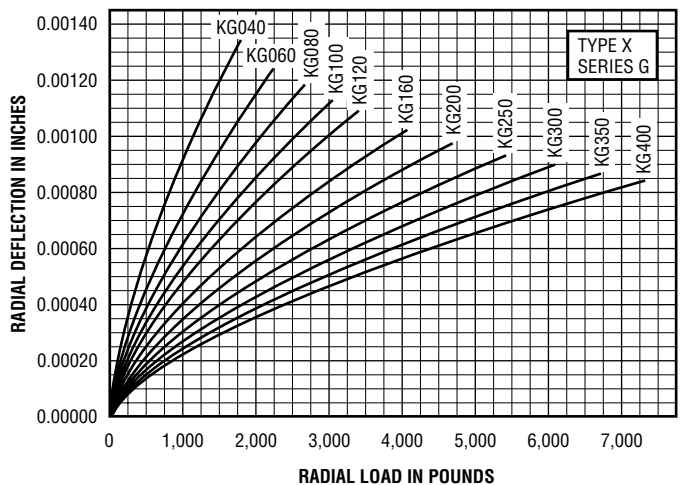
**Figure 82**



**Figure 80**



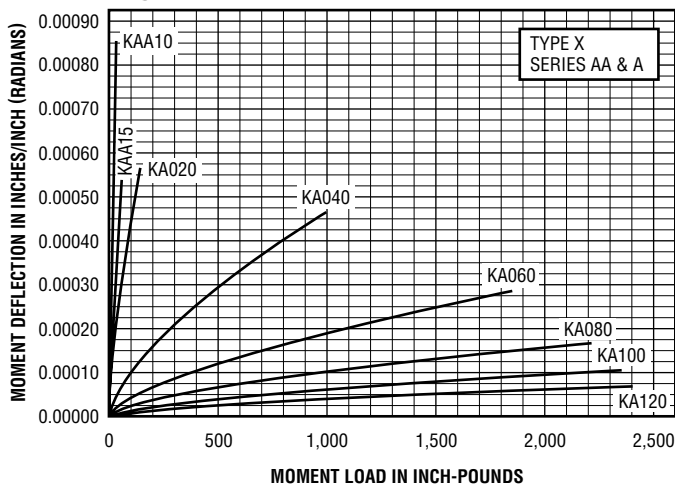
**Figure 83**



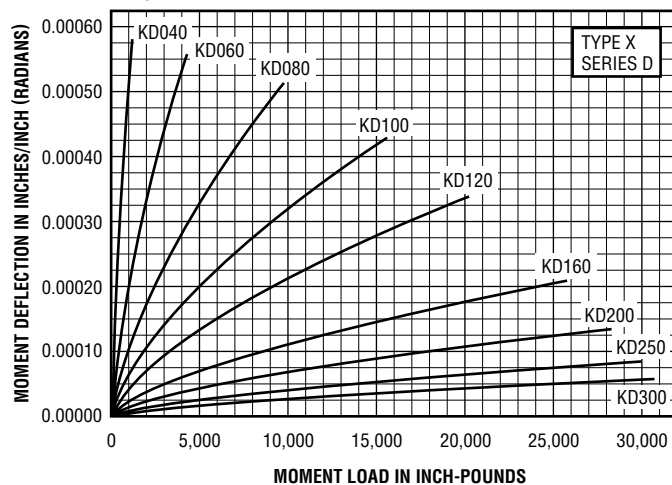
# Moment Deflection vs. Moment Load

## Type X Four-Point Contact

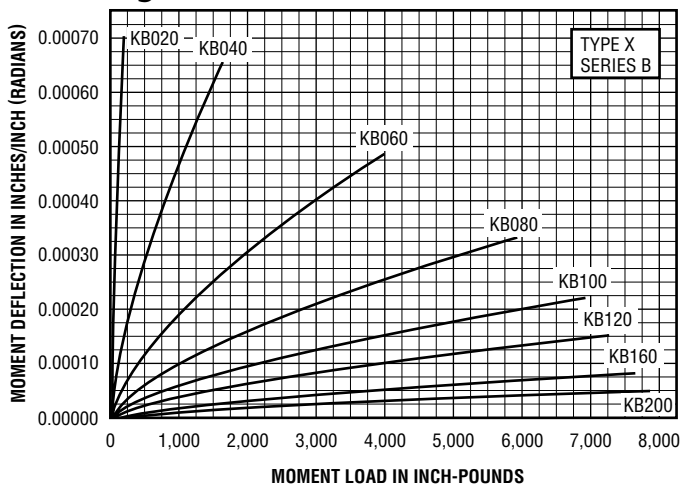
**Figure 84**



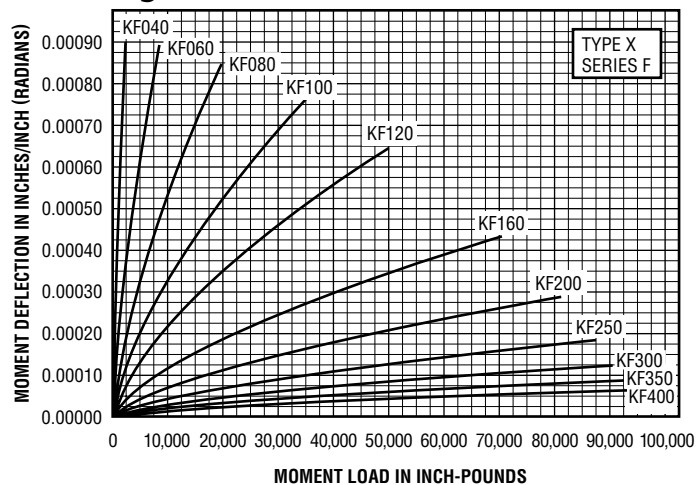
**Figure 87**



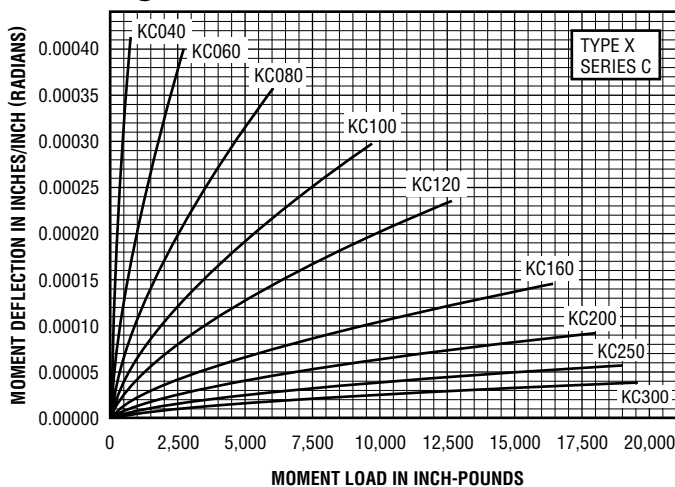
**Figure 85**



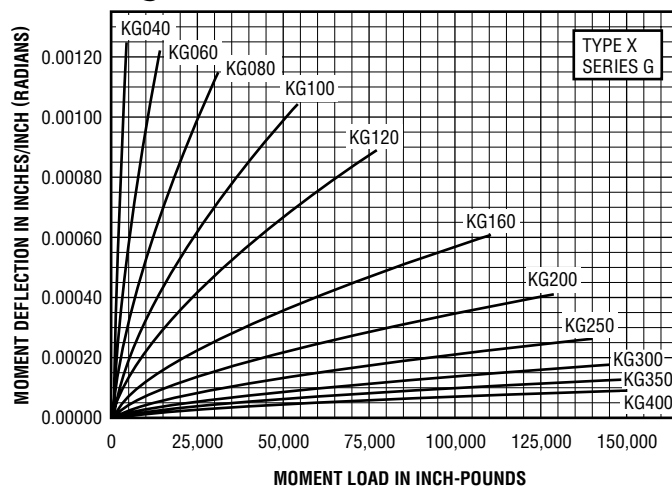
**Figure 88**



**Figure 86**



**Figure 89**



Section 4 - Performance Considerations

## **Section 5— Installation and Maintenance**

- **Inspection and Installation Procedures....pgs. 81-82**
- **Lubrication and Maintenance ..... pgs. 83-84**



# Inspection and Installation Procedures

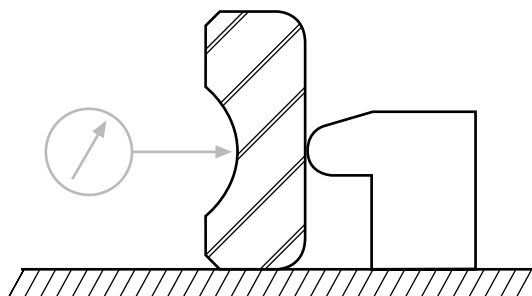
## Inspection

The unique proportions of Reali-Slim® bearings make some of the usual gaging practices impractical. Since very light pressure is sufficient to deflect the thin rings, conventional two-point measurement of bearing bore and outside diameter must not be used. Air gages of the open jet type, or other proximity devices, must be used to hold error from distortion to an acceptable level. Measurements must be made at enough points to yield a true average size, which may not be the mean of the maximum and minimum measurement. A Reali-Slim® bearing may be out-of-round in the free state<sup>①</sup> more than the ABMA tolerance for its precision class. This presents no problem since the races will conform readily to a round shaft diameter and housing bore.

To determine the true runout of each race, by excluding the effect of out of roundness, measurement is made of variation in individual wall thickness. This is schematically illustrated in Figure 90. The indicator must contact the raceway at the ball or roller contact, and must be properly positioned for the particular runout (axial or radial) being checked.

## Measurement of Radial Runout of Type C Inner Race

Figure 90



Diametral clearance of Reali-Slim® bearings is controlled by selective assembly of races and balls following measurement with gages specially design for this purpose.

Standard inspection and quality control procedures at Kaydon meet the requirements of government procurement agencies and major aerospace industries. However, a certificate of compliance to specifications can be furnished if required.

## Installation

To realize the potential accuracy and long trouble-free life of a Reali-Slim® bearing, it is important that the installation be properly done in a clean environment. Cleanliness is vital to satisfactory bearing performance. Work surfaces and tools must be free of dirt, chips, and burrs. Disposable wipers or clean, lint-free cloths should be used.

Under no circumstances should a bearing be used as a gage during grinding or machining of mating parts. Just a few grains of grinding grit or chips of metal (soft as well as hard) can seriously damage the precise geometry and finishes of bearing raceways and rolling elements, and are nearly impossible to remove from an assembled bearing.

The shaft and housing should be thoroughly cleaned, special attention being given to holes and crevices which could hold dirt, chips, and cutting oil. Unfinished surfaces of castings should be painted or otherwise sealed. The mounting surfaces for the bearing must be carefully checked, cleaned, and lightly oiled to ease fitting and minimize danger of scoring. Housing bore, shaft diameter, shoulder squareness, and fillet sizes should all be verified.

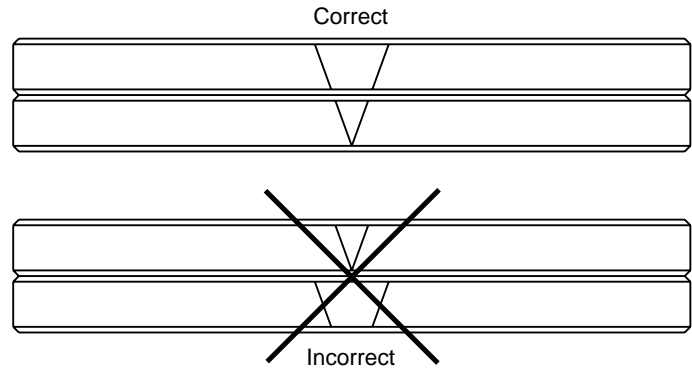
Only when all this has been done and it is time to install the bearing, should it be removed from its protective package.

<sup>①</sup> As explained in ABMA Standard 26.2

Interference fitting any bearing to the shaft or housing must be carefully done to avoid injury to the bearing. For Reali-Slim® bearings, the use of temperature difference is recommended to minimize or eliminate the forces necessary. To calculate the differential required, use a coefficient of expansion of .000007 inch per inch per degree F for 52100 steel races. For a Kaydon Precision Class 1 bearing of 2" bore to be fitted to a steel shaft, the differential required to eliminate all interference between a maximum diameter shaft and minimum diameter bearing is 90°F, for a 4" bore it is 60°F. Either dry heat or hot oil may be used. Electrical resistance tape is convenient for the large bearings. Care must be taken to avoid overheating the bearing. Do not exceed 250°F.

If pressure is necessary, an arbor press should be used with a suitable pusher to apply the force to all 360° of the race being press fitted—never to the other race as damage will be done to the balls and raceways.

All duplexed bearings are marked with a single "V" on the bores and outside diameters to indicate the proper relative circumferential position of inner and outer races. This "V" is located at the high points of race eccentricity so that these may be placed at the low points of shaft and housing eccentricity for the canceling effect.



After mounting, the bearings must be given continued protection from contamination until the assembly is closed. Adherence to these procedures will assure a successful installation.

If bearings are being returned to verify dimensions and tolerances, they should be coated with protective oil and wrapped well to prevent damage during transit. If bearings are being returned after use for a failure analysis, they should be returned in the as removed condition, since the condition of the part (cleanliness, lubricated condition, etc.) will provide useful clues for considerations.

**CONTACT KAYDON AT—**  
 Kaydon Corporation • Muskegon, Michigan 49443  
 Telephone: 231/755-3741 • Fax: 231/759-4102

**NEED SERVICE FAST?**  
**1-800-514-3066**  
 Website: [www.reali-slim.com](http://www.reali-slim.com)

# Lubrication and Maintenance

The lubricant in an anti-friction bearing serves to reduce friction and wear between moving parts, to dissipate heat, and to prevent corrosion of critical surfaces. Selection of the proper lubricant must be based on satisfaction of the operating conditions, including rotational speed, type and magnitude of loads, and ambient temperature.

The three types of lubricant commonly used are oil, grease, and dry film or surface treatment.

Oil normally provides more complete lubrication. Because of its liquid state, it provides better coverage of the critical surfaces and assists in dissipating heat more readily, the latter being especially true when circulation and cooling are provided. In high speed applications where the heating effect is more pronounced, oil is generally mandatory (see page 69). Where minimum torque is a requirement, oil will usually provide lower friction values.

Grease offers certain advantages of its own. Because it is more easily retained, the design of bearing housings and seals is simplified. In many applications, the lubricant itself serves to exclude contaminants when used in conjunction with labyrinths or close clearances between the rotating and stationary structures. Applications using a high quality bearing grease will perform for long periods of time with little or no maintenance where operating conditions are not severe. For the higher speeds within the range suitable for grease lubrication, a channeling type grease is recommended.

Dry films and surface treatments have been used as bearing lubricants in applications subject to environmental extremes, particularly where conventional lubricants cannot be tolerated or will not survive. A wide variety of types are available and can be furnished, including Tungsten disulfide, graphite, and Molybdenum disulfide.

It is important to note that the quantity of lubricant affects bearing performance under certain operating conditions. Only relatively small amounts of lubricant are necessary to reduce friction and wear if a film can be maintained on all contacting surfaces. Where speed is significant, excessive amounts of oil or grease will result in higher operating temperatures, leading to the possibility of early bearing fatigue.

Unsealed bearings are supplied with a coating of preservative type lubricating oil for the prevention of corrosion during storage. For best performance it is recommended that this preservative be removed with clean solvent prior to lubricating during assembly. If this is not done, the end user should verify the lubricant used is compatible with the preservative.

In applications where minimum torque is required, the coating should be removed by washing with a clean petroleum solvent followed by immediate relubrication with a light spindle oil. When desired, it is a common commercial option to have Reali-Slim® bearings factory-lubricated with a commercial grease or oil for direct installation by the customer.

Sealed bearings are packed approximately one-third full with a multi-purpose industrial grease. Exterior surfaces are given a light coating of the same lubricant for protection during storage in the original package.

The initial grease pack is usually good for the life of the bearing, but operating conditions may cause the grease to lose its properties before the theoretical bearing fatigue life. If relubrication proves necessary, grease may be injected with a hypodermic syringe. In most cases, however, it is better practice to replace a bearing with identified grease failure. If required, sealed bearings can be supplied with alternate greases as a commercial option.

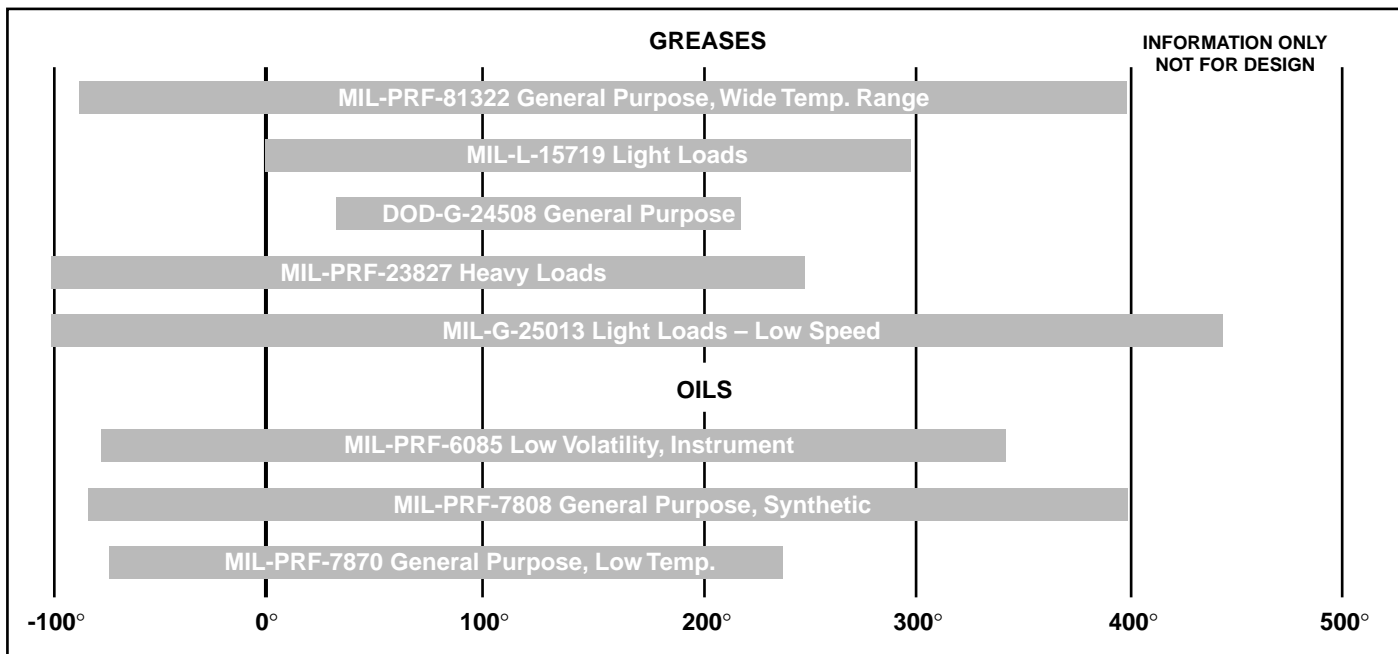
Bearings, with or without seals, can be supplied with optional lubricants. Shown in the accompanying table are some of the greases and oils more frequently specified. Several have been developed to meet the requirements of unusual operating conditions. Because of this, and the variation in cost, it is recommended that lubricants be selected with the assistance of a lubrication expert.

Due to the finite shelf life of any wet lubricant, factory lubricated bearings should not be held more than 2 years prior to use.

Contact Kaydon for refurbishment instructions for product held beyond 2 years of receipt.

It is an unfortunate fact that most bearings fail due to abuse and/or neglect. To realize the full potential life of a Reali-Slim® bearing, protection must be afforded against the intrusion of foreign matter of all types, and fresh oil or grease must be introduced with sufficient frequency to cleanse the bearing and assure continued good lubrication.

**Figure 93**  
**Lubrication Temperature Ranges**



## Section 6—Other Products

- **Hybrid Series Bearings (Material Codes P, Q, X, and Y) for Harsh Environments .....pgs. 86-87**
- **Metric Series Bearings .....pgs. 88-97**
- **Ultra-Slim Series Bearings .....pgs. 98-100**
- **KT Series Tapered Roller Bearings ....pgs. 102-103**
- **TG Series Bearing Assemblies .....pg. 101**

# Harsh Environment Bearings (Material Codes S, P, X, and Y)

## **Kaydon's stock line of stainless steel bearings are used where high precision and corrosion resistance are required.**

Reali-Slim® thin-section bearings are available in 440C stainless steel races, brass or non-metallic separators, and your choice of either stainless steel or ceramic balls. Offered in either radial contact "C," angular contact "A," or four-point contact "X" configurations. These bearings minimize the surface degradation and particulate formation so common in harsh environment applications. Best of all, these bearings are available in popular sizes from stock for immediate delivery. (See pages 35-37.)

## **Hybrid bearings are very well suited for applications where lubrication is marginal.**

Kaydon Real-Slim® bearing performance is legendary in demanding applications. That's because these high-precision, compact, lightweight bearings feature low torque, high temperature performance, outstanding cleanliness, and superior chemical compatibility.

Kaydon's Reali-Slim® thin-section bearing product line has been expanded to include several additional bearing series specifically engineered to bring the advantages of Reali-Slim® bearings to designs intended for service in the most severe or extreme envi-

ronments. We offer Reali-Slim® bearings with a variety of packaged features to meet specific operation requirements for:

- Chemical resistance/high temperature—P Series (See page 87.)
- High performance/low torque—Q Series (See page 70.)
- High performance/low particle—X, Y Series

Applications requiring low particle generation, high accuracy, high speeds, and/or which must operate in adverse or no-lube conditions, can benefit from hybrid bearings. Tests have shown that significant reductions in particle generation can be obtained with hybrid designs which incorporate the use of ceramic rolling elements on hardened steel races. In addition, the physical properties of the ceramic rolling elements (precision, hardness, lightweight) provide additional benefits such as improved repeatability, low torque, high stiffness, and resistance to breakdown under marginal or no-lube conditions.

Tremendous benefits in performance can be obtained by matching not just size but also material to the application. These alternative race and ball materials interact differently than traditional chrome steel bearings. Capacities, life calculations, stiffness, and mounting requirements should be obtained from KAYDON to help assure maximum performance is realized.

**Series P—Chemical Resistant**

In applications where both corrosion resistance and chemical resistance are required, series P bearings may be required. These bearings feature 17-4PH steel races and ceramic balls. They're manufactured to provide a greater level of corrosion and chemical resistance than either Kaydon Series N or Series S bearings. Due to the hardening limitations of 17-4PH steel, an adjustment factor of .17 must be applied to the standard dynamic capacity ratings. Thus, the use of P Series bearings should be carefully reviewed prior to selection to determine if the life and capacity are adequate.

**Materials**

Races	17-4PH steel
Balls	Borosilicate, glass, or ceramic
Cage	Type A; PTFE or Vespel® toroid ball spacers or 300 series steel ring Type C & X; Stainless steel or non-metallic composite ring

**Specifications for Hybrid Reali-Slim® Bearings**

ITEM	DESCRIPTION	REFERENCE SPECIFICATION
<b>MATERIAL ANALYSIS</b>		
<b>RACES</b>	AISI 440C Stainless steel	ASTM A-756
<b>BALLS</b>	440C Stainless steel or ceramic: Silicon Nitride	
<b>SEPARATORS</b> <b>C, X BEARINGS</b> <b>A BEARINGS</b>	P Type—Brass or non-metallic composite L Type—Nylon, fiberglass reinforced R Type—Brass or non-metallic composite G Type—Nylon, fiberglass reinforced	ASTM B-36 or B-134 ASTM B-36 or B-134
<b>HEAT TREATMENT</b>		
<b>RACES</b>	Through hardened and dimensionally stabilized for use from -65°F to +250°F (-54°C to +121°C), Rc 58 min.	SAE-AMS-H-6875 with approved proprietary modifications
<b>BALLS</b>	Hardened to Rc 58-65, Ceramic—Rc 75 min.	ABMA Std. 10, MIL-B-1083
<b>PRECISION</b>		
<b>RACE DIMENSIONS</b>	KAYDON Precision Class 1, Higher classes available	ABMA ABEC-1F or better
<b>RACE RUNOUTS</b>	KAYDON Precision Class 1, Higher classes available	ABMA ABEC-1F or better
<b>BALLS</b>	Grade 24 Stainless steel or Grade 5 ceramic	ANSI/ABMA/ISO 3290

} other options, see p. 63

# Metric Real-Slim® Bearing Selections

## Type A

### Angular Contact

#### How to identify Metric Real-Slim® Bearings using our part number code:

Standard and modified metric Real-Slim bearings are marked for complete identification with a 9 or 10 digit part number. Positions 1–9 identify materials, size, type, separator type, and precision. Position 10 (optional) identifies non-standard internal fit, either preload or clearance. Custom and proprietary bearings cannot be identified by code, and are marked only with a nine digit number.

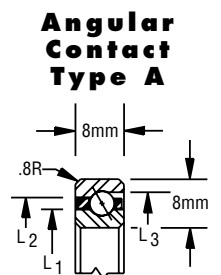
Position	1	2	3	4	5	6	7	8	9	10
Nomenclature	Material	Bore (mm)			Width (mm)		Type	Separator	Precision	Internal Fit
Example	K	0	8	0	0	8	X	P	0	K

#### Explanation of position numbers:

- 1) K = 52100 steel  
S = 440C stainless  
N = Endurakote®
- 2) P = Standard formed ring snap-over type  
R = Standard formed ring circular pocket type
- 3) 0 = Precision Class 1 (ABEC 1F) standard
- 4) 10 empty = Standard (See table, p. 94)  
A = .0000 to .0127 mm clearance  
K = .0000 to .0127 mm preload  
L = .0000 to .0254 mm preload  
Z = other clearance or preload not specified above
- 7) A = Angular contact  
C = Radial contact  
X = Four-point contact

Section 6 - Other Products

8 mm SERIES												
Kaydon Bearing Number	DIMENSIONS					CAPACITY						Weight kg
	Size (mm)		Land Diameters (mm)			Radial (kg)		Axial (kg)		Moment (kg-M)		
	Bore	O.D.	Land (L1)	Land (L2)	Land (L3)	Static	Dyn.	Static	Dyn.	Static	Dyn.	
K02008AR0	20	36	25.9	30.1	31.7	306	171	884	493	—	—	0.05
K02508AR0	25	41	30.5	35.1	36.7	372	194	1073	561	—	—	0.06
K05008AR0	50	66	55.9	60.1	61.7	656	284	1894	819	—	—	0.08
K06008AR0	60	76	65.9	70.1	71.7	787	321	2273	925	—	—	0.09
K07008AR0	70	86	75.9	80.1	81.7	896	350	2588	1009	—	—	0.10
K08008AR0	80	96	85.9	90.1	91.7	1006	377	2903	1090	—	—	0.12
K09008AR0	90	106	95.9	100.1	101.7	1137	410	3282	1182	—	—	0.13
K10008AR0	100	116	105.9	110.1	111.7	1246	435	3598	1257	—	—	0.14
K11008AR0	110	126	115.9	120.1	121.7	1356	460	3914	1329	—	—	0.15
K12008AR0	120	136	125.9	130.1	131.7	1465	485	4229	1400	—	—	0.16
K13008AR0	130	146	135.9	140.1	141.7	1596	513	4608	1482	—	—	0.17
K14008AR0	140	156	145.9	150.1	151.7	1706	537	4923	1549	—	—	0.18
K15008AR0	150	166	155.9	160.1	161.7	1815	559	5239	1615	—	—	0.20
K16008AR0	160	176	165.9	170.1	171.7	1946	586	5618	1691	—	—	0.20
K17008AR0	170	186	175.9	180.1	181.6	2055	608	5933	1754	—	—	0.21
K18008AR0	180	196	185.9	190.1	191.6	2165	629	6249	1816	—	—	0.22
K19008AR0	190	206	195.9	200.1	201.6	2296	654	6628	1889	—	—	0.23
K20008AR0	200	216	205.9	210.1	211.6	2405	675	6944	1948	—	—	0.23
K25008AR0	250	266	255.9	260.1	261.6	2974	777	8585	2244	—	—	0.28
K30008AR0	300	316	305.9	310.1	311.6	3564	877	10289	2532	—	—	0.33
K32008AR0	320	336	325.9	330.1	331.6	3805	916	10983	2645	—	—	0.36
K34008AR0	340	356	345.9	350.1	351.6	4023	951	11614	2745	—	—	0.38
K36008AR0	360	376	365.9	370.1	371.6	4264	988	12309	2854	—	—	0.40



① Capacities listed are not simultaneous. For combined loading see discussion of Bearing Selection and Load Analysis. Dynamic capacities are based upon 1 million revolutions of L10 life. Published capacities do not apply to hybrid series bearings P, X, and Y - contact Kaydon product engineering for values.

② Static capacities are non-brinell limits based on rigid support from the shaft and housing.

③ "F" is the maximum shaft or housing fillet radius the bearing corners will clear.  
All dimensions in millimeters. Contact Kaydon for lead time.

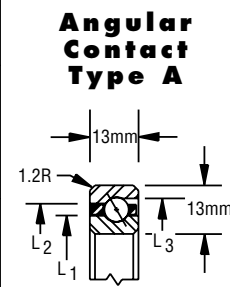


# Metric Reali-Slim® Bearing Selections

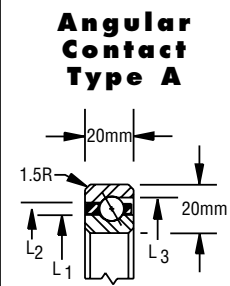
## Type A

### Angular Contact (See footnotes on previous page.)

13 mm SERIES												
Kaydon Bearing Number	DIMENSIONS					CAPACITY						Weight kg
	Size (mm)		Land Diameters (mm)			Radial (kg)		Axial (kg)		Moment (kg-M)		
	Bore	O.D.	Land (L1)	Land (L2)	Land (L3)	Static	Dyn.	Static	Dyn.	Static	Dyn.	
K02013AR0	20	46	20.4	45.6	45.7	560	349	1616	1008	—	—	0.11
K02513AR0	25	51	25.4	50.6	50.7	616	372	1778	1075	—	—	0.13
K05013AR0	50	76	50.4	75.6	75.7	1064	536	3070	1547	—	—	0.20
K06013AR0	60	86	60.4	85.6	85.7	1232	591	3555	1706	—	—	0.22
K07013AR0	70	96	70.4	95.6	95.7	1456	660	4201	1906	—	—	0.25
K08013AR0	80	106	80.4	105.6	105.7	1623	710	4686	2050	—	—	0.28
K09013AR0	90	116	90.4	115.6	115.7	1791	758	5171	2190	—	—	0.31
K10013AR0	100	126	100.4	125.6	125.7	1959	805	5656	2324	—	—	0.34
K11013AR0	110	136	110.4	135.6	135.7	2127	851	6141	2455	—	—	0.37
K12013AR0	120	146	120.4	145.6	145.7	2295	895	6625	2583	—	—	0.39
K13013AR0	130	156	130.4	155.6	155.7	2519	952	7272	2748	—	—	0.42
K14013AR0	140	166	140.4	165.6	165.7	2687	994	7757	2869	—	—	0.45
K15013AR0	150	176	150.4	175.6	175.7	2855	1035	8241	2987	—	—	0.48
K16013AR0	160	186	160.4	185.6	185.7	3023	1075	8726	3104	—	—	0.51
K17013AR0	170	196	170.4	195.6	195.7	3191	1114	9211	3217	—	—	0.54
K18013AR0	180	206	180.4	205.6	205.7	3359	1154	9696	3329	—	—	0.56
K19013AR0	190	216	190.4	215.6	215.7	3527	1192	10181	3439	—	—	0.59
K20013AR0	200	226	200.4	225.6	225.7	3750	1242	10827	3583	—	—	0.62
K25013AR0	250	276	250.4	275.6	275.7	4590	1420	13251	4100	—	—	0.76
K30013AR0	300	326	300.4	325.6	325.7	5486	1599	15837	4618	—	—	0.90
K32013AR0	320	346	320.4	345.6	345.7	5822	1664	16806	4804	—	—	0.96
K34013AR0	340	366	340.4	365.6	365.7	6213	1738	17937	5017	—	—	1.02
K36013AR0	360	386	360.4	385.6	385.7	6550	1800	18907	5196	—	—	1.07



20 mm SERIES												
Kaydon Bearing Number	DIMENSIONS					CAPACITY						Weight kg
	Size (mm)		Land Diameters (mm)			Radial (kg)		Axial (kg)		Moment (kg-M)		
	Bore	O.D.	Land (L1)	Land (L2)	Land (L3)	Static	Dyn.	Static	Dyn.	Static	Dyn.	
K02020AR0	20	60	35.0	45.0	49.1	1007	677	2908	1955	—	—	0.28
K02520AR0	25	65	40.0	50.0	54.1	1134	733	3272	2115	—	—	0.31
K05020AR0	50	90	65.0	75.0	79.1	1889	1030	5454	2973	—	—	0.49
K06020AR0	60	100	75.0	85.0	89.1	2141	1119	6181	3231	—	—	0.56
K07020AR0	70	110	85.0	95.0	99.1	2393	1206	6908	3480	—	—	0.62
K08020AR0	80	120	95.0	105.0	109.1	2645	1289	7635	3720	—	—	0.69
K09020AR0	90	130	105.0	115.0	119.1	3023	1409	8726	4067	—	—	0.77
K10020AR0	100	140	115.0	125.0	129.1	3275	1486	9453	4290	—	—	0.84
K11020AR0	110	150	125.0	135.0	139.1	3527	1561	10181	4507	—	—	0.91
K12020AR0	120	160	135.0	145.0	149.1	3778	1635	10908	4719	—	—	0.97
K13020AR0	130	170	145.0	155.0	159.1	4030	1706	11635	4927	—	—	1.04
K14020AR0	140	180	155.0	165.0	169.1	4282	1777	12362	5130	—	—	1.11
K15020AR0	150	190	165.0	175.0	179.1	4660	1880	13453	5427	—	—	1.19
K16020AR0	160	200	175.0	185.0	189.1	4912	1948	14180	5621	—	—	1.26
K17020AR0	170	210	185.0	195.0	199.1	5146	2013	14907	5811	—	—	1.32
K18020AR0	180	220	195.0	205.0	209.1	5416	2078	15634	5999	—	—	1.39
K19020AR0	190	230	205.0	215.0	219.1	5668	2142	16361	6183	—	—	1.46
K20020AR0	200	240	215.0	225.0	229.1	6045	2236	17452	6455	—	—	1.54
K25020AR0	250	290	265.0	275.0	279.1	7431	2566	21452	7408	—	—	1.89
K30020AR0	300	340	315.0	325.0	329.1	8691	2848	25088	8222	—	—	2.23
K32020AR0	320	360	335.0	345.0	349.1	9321	2984	26906	8615	—	—	2.37
K34020AR0	340	380	355.0	365.0	369.1	9824	3091	28360	8923	—	—	2.51
K36020AR0	360	400	375.0	385.0	389.1	10454	3221	30178	9300	—	—	2.66



Section 6-Other Products

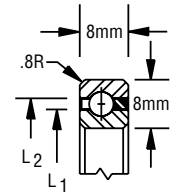
# Metric Reali-Slim® Bearing Selections

## Type C

### Radial Contact

8 mm SERIES												
Kaydon Bearing Number	DIMENSIONS				CAPACITY						Weight kg	
	Size (mm)		Land Diameters (mm)		Radial (kg)		Axial (kg)		Moment (kg-M)			
	Bore	O.D.	Land (L1)	Land (L2)	Static	Dyn.	Static	Dyn.	Static	Dyn.		
K02008CP0	20	36	25.9	30.1	278	168	—	—	—	—	0.05	
K02508CP0	25	41	30.9	35.1	303	178	—	—	—	—	0.06	
K05008CP0	50	66	55.9	60.1	556	267	—	—	—	—	0.08	
K06008CP0	60	76	65.9	70.1	656	298	—	—	—	—	0.09	
K07008CP0	70	86	75.9	80.1	758	327	—	—	—	—	0.10	
K08008CP0	80	96	85.9	90.1	859	356	—	—	—	—	0.11	
K09008CP0	90	106	95.9	100.1	959	384	—	—	—	—	0.13	
K10008CP0	100	116	105.9	110.1	1061	410	—	—	—	—	0.14	
K11008CP0	110	126	115.9	120.1	1162	436	—	—	—	—	0.15	
K12008CP0	120	136	125.9	130.1	1262	461	—	—	—	—	0.16	
K13008CP0	130	146	135.9	140.1	1364	485	—	—	—	—	0.17	
K14008CP0	140	156	145.9	150.1	1465	508	—	—	—	—	0.18	
K15008CP0	150	166	155.9	160.1	1565	532	—	—	—	—	0.20	
K16008CP0	160	176	165.9	170.1	1666	554	—	—	—	—	0.20	
K17008CP0	170	186	175.9	180.1	1767	577	—	—	—	—	0.20	
K18008CP0	180	196	185.9	190.1	1868	598	—	—	—	—	0.21	
K19008CP0	190	206	195.9	200.1	1944	614	—	—	—	—	0.21	
K20008CP0	200	216	205.9	210.1	2045	635	—	—	—	—	0.22	
K25008CP0	250	266	255.9	260.1	2550	736	—	—	—	—	0.28	
K30008CP0	300	316	305.9	310.1	3055	831	—	—	—	—	0.35	
K32008CP0	320	336	325.9	330.1	3257	866	—	—	—	—	0.39	
K34008CP0	340	356	345.9	350.1	3459	902	—	—	—	—	0.42	
K36008CP0	360	376	365.9	370.1	3636	933	—	—	—	—	0.46	

**Conrad Assembly Type C**



- ① Capacities listed are not simultaneous. For combined loading see discussion of Bearing Selection and Load Analysis. Dynamic capacities are based upon 1 million revolutions of L10 life. Published capacities do not apply to hybrid series bearings P, X, and Y - contact Kaydon product engineering for values.
  - ② Static capacities are non-brinell limits based on rigid support from the shaft and housing.
  - ③ "F" is the maximum shaft or housing fillet radius the bearing corners will clear.
- All dimensions in millimeters. Contact Kaydon for lead time.

Section 6—Other Products

**CONTACT KAYDON AT—**

Kaydon Corporation • Muskegon, Michigan 49443  
 Telephone: 231/755-3741 • Fax: 231/759-4102

**NEED SERVICE FAST?**

1-800-514-3066  
 Website: [www.reali-slim.com](http://www.reali-slim.com)

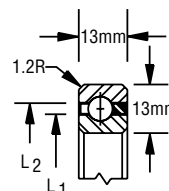
# Metric Reali-Slim® Bearing Selections

## Type C

### Radial Contact (See footnotes on previous page.)

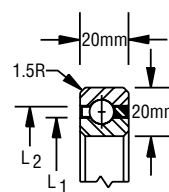
13 mm SERIES												
Kaydon Bearing Number	DIMENSIONS				CAPACITY						Weight kg	
	Size (mm)		Land Diameters (mm)		Radial (kg)		Axial (kg)		Moment (kg-M)			
	Bore	O.D.	Land (L1)	Land (L2)	Static	Dyn.	Static	Dyn.	Static	Dyn.		
K02013CP0	20	46	29.7	36.3	453	318	—	—	—	—	0.09	
K02513CP0	25	51	34.7	41.3	517	347	—	—	—	—	0.11	
K05013CP0	50	76	59.7	66.3	905	505	—	—	—	—	0.18	
K06013CP0	60	86	69.7	76.3	1099	575	—	—	—	—	0.21	
K07013CP0	70	96	79.7	86.3	1228	619	—	—	—	—	0.24	
K08013CP0	80	106	89.7	96.3	1358	661	—	—	—	—	0.26	
K09013CP0	90	116	99.7	106.3	1551	723	—	—	—	—	0.29	
K10013CP0	100	126	109.7	116.3	1681	763	—	—	—	—	0.32	
K11013CP0	110	136	119.7	126.3	1875	820	—	—	—	—	0.35	
K12013CP0	120	146	129.7	136.3	2004	857	—	—	—	—	0.38	
K13013CP0	130	156	139.7	146.3	2133	894	—	—	—	—	0.41	
K14013CP0	140	166	149.7	156.3	2327	948	—	—	—	—	0.44	
K15013CP0	150	176	159.7	166.3	2456	982	—	—	—	—	0.46	
K16013CP0	160	186	169.7	176.3	2586	1017	—	—	—	—	0.49	
K17013CP0	170	196	179.7	186.3	2780	1066	—	—	—	—	0.52	
K18013CP0	180	206	189.7	196.3	2909	1100	—	—	—	—	0.55	
K19013CP0	190	216	199.7	206.3	3038	1132	—	—	—	—	0.58	
K20013CP0	200	226	209.7	216.3	3232	1179	—	—	—	—	0.61	
K25013CP0	250	276	259.7	266.3	4008	1361	—	—	—	—	0.75	
K30013CP0	300	326	309.7	316.3	4719	1518	—	—	—	—	0.89	
K32013CP0	320	346	329.7	336.3	5042	1586	—	—	—	—	0.95	
K34013CP0	340	366	349.7	356.3	5365	1653	—	—	—	—	1.01	
K36013CP0	360	386	369.7	376.3	5688	1719	—	—	—	—	1.06	

**Conrad Assembly Type C**



20 mm SERIES												
Kaydon Bearing Number	DIMENSIONS				CAPACITY						Weight kg	
	Size (mm)		Land Diameters (mm)		Radial (kg)		Axial (kg)		Moment (kg-M)			
	Bore	O.D.	Land (L1)	Land (L2)	Static	Dyn.	Static	Dyn.	Static	Dyn.		
K02020CP0	20	60	35.0	45.0	873	645	—	—	—	—	0.30	
K02520CP0	25	65	40.0	50.0	1018	715	—	—	—	—	0.34	
K05020CP0	50	90	65.0	75.0	1600	967	—	—	—	—	0.51	
K06020CP0	60	100	75.0	85.0	1745	1025	—	—	—	—	0.58	
K07020CP0	70	110	85.0	95.0	2036	1136	—	—	—	—	0.65	
K08020CP0	80	120	95.0	105.0	2181	1189	—	—	—	—	0.72	
K09020CP0	90	130	105.0	115.0	2473	1293	—	—	—	—	0.80	
K10020CP0	100	140	115.0	125.0	2618	1343	—	—	—	—	0.86	
K11020CP0	110	150	125.0	135.0	2909	1441	—	—	—	—	0.94	
K12020CP0	120	160	135.0	145.0	3200	1535	—	—	—	—	1.01	
K13020CP0	130	170	145.0	155.0	3345	1581	—	—	—	—	1.08	
K14020CP0	140	180	155.0	165.0	3636	1672	—	—	—	—	1.15	
K15020CP0	150	190	165.0	175.0	3781	1716	—	—	—	—	1.20	
K16020CP0	160	200	175.0	185.0	4072	1803	—	—	—	—	1.30	
K17020CP0	170	210	185.0	195.0	4363	1887	—	—	—	—	1.40	
K18020CP0	180	220	195.0	205.0	4508	1929	—	—	—	—	1.50	
K19020CP0	190	230	205.0	215.0	4800	2011	—	—	—	—	1.50	
K20020CP0	200	240	215.0	225.0	4945	2052	—	—	—	—	1.60	
K25020CP0	250	290	265.0	275.0	6108	2362	—	—	—	—	2.10	
K30020CP0	300	340	315.0	325.0	7272	2654	—	—	—	—	2.30	
K32020CP0	320	360	335.0	345.0	7708	2758	—	—	—	—	2.42	
K34020CP0	340	380	355.0	365.0	8144	2862	—	—	—	—	2.54	
K36020CP0	360	400	375.0	385.0	8581	2963	—	—	—	—	2.70	

**Conrad Assembly Type C**



Section 6-Other Products

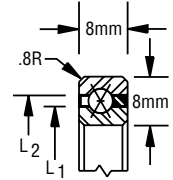
# Metric Reali-Slim® Bearing Selections

## Type X

### Four-Point Contact

8 mm SERIES											
Kaydon Bearing Number	DIMENSIONS				CAPACITY						Weight kg
	Size (mm)		Land Diameters (mm)		Radial (kg)		Axial (kg)		Moment (kg-M)		
	Bore	O.D.	Land (L1)	Land (L2)	Static	Dyn.	Static	Dyn.	Static	Dyn.	
K02008XP0	20	36	25.9	30.1	278	168	695	420	3.9	2.3	0.03
K02508XP0	25	41	30.5	35.1	303	187	758	469	5.0	3.1	0.04
K05008XP0	50	66	55.9	60.1	555	267	1389	666	16.1	7.7	0.07
K06008XP0	60	76	65.9	70.1	656	298	1641	745	22.3	10.1	0.09
K07008XP0	70	86	75.9	80.1	757	327	1894	819	29.5	12.8	0.10
K08008XP0	80	96	85.9	90.1	859	356	2146	890	37.7	15.7	0.11
K09008XP0	90	106	95.9	100.1	959	384	2399	959	46.9	18.8	0.13
K10008XP0	100	116	105.9	110.1	1060	410	2651	1025	57.2	22.1	0.14
K11008XP0	110	126	115.9	120.1	1162	436	2903	1090	68.4	25.7	0.15
K12008XP0	120	136	125.9	130.1	1262	461	3156	1152	80.6	29.5	0.16
K13008XP0	130	146	135.9	140.1	1363	485	3409	1212	93.9	33.4	0.18
K14008XP0	140	156	145.9	150.1	1465	508	3661	1271	108	37.6	0.19
K15008XP0	150	166	155.9	160.1	1565	532	3914	1329	123	42	0.20
K16008XP0	160	176	165.9	170.1	1666	554	4166	1386	140	46.5	0.20
K17008XP0	170	186	175.9	180.1	1767	577	4418	1441	157	51.2	0.20
K18008XP0	180	196	185.9	190.1	1868	598	4671	1495	175	56.1	0.21
K19008XP0	190	206	195.9	200.1	1944	614	4860	1536	192	60.7	0.21
K20008XP0	200	216	205.9	210.1	2045	635	5113	1588	212	66	0.22
K25008XP0	250	266	255.9	260.1	2550	736	6375	1840	328	94.8	0.28
K30008XP0	300	316	305.9	310.1	3055	831	7638	2076	470	128	0.35
K32008XP0	320	336	325.9	330.1	3257	866	8143	2166	533	142	0.39
K34008XP0	340	356	345.9	350.1	3459	902	8648	2255	601	157	0.42
K36008XP0	360	376	365.9	370.1	3636	933	9089	2330	668	171	0.46

**4 Point Contact Type X**



- ① Capacities listed are not simultaneous. For combined loading see discussion of Bearing Selection and Load Analysis. Dynamic capacities are based upon 1 million revolutions of L10 life. Published capacities do not apply to hybrid series bearings P, X, and Y - contact Kaydon product engineering for values.
  - ② Static capacities are non-brinell limits based on rigid support from the shaft and housing.
  - ③ "F" is the maximum shaft or housing fillet radius the bearing corners will clear.
- All dimensions in millimeters. Contact Kaydon for lead time.

Section 6 - Other Products

**CONTACT KAYDON AT—**

Kaydon Corporation • Muskegon, Michigan 49443  
 Telephone: 231/755-3741 • Fax: 231/759-4102

**NEED SERVICE FAST?**

1-800-514-3066  
 Website: [www.reali-slim.com](http://www.reali-slim.com)

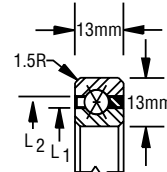
# Metric Reali-Slim® Bearing Selections

## Type X

### Four-Point Contact (See footnotes on previous page.)

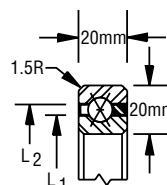
13mm SERIES											
Kaydon Bearing Number	DIMENSIONS				CAPACITY						Weight kg
	Size (mm)		Land Diameters (mm)		Radial (kg)		Axial (kg)		Moment (kg-M)		
	Bore	O.D.	Land (L1)	Land (L2)	Static	Dyn.	Static	Dyn.	Static	Dyn.	
K02013XP0	20	46	29.7	36.3	453	318	1131	795	7	5	0.11
K02513XP0	25	51	34.7	41.3	517	347	1293	869	10	7	0.13
K05013XP0	50	76	59.7	66.3	905	505	2263	1226	28	16	0.20
K06013XP0	60	86	69.7	76.3	1099	575	2747	1436	40	21	0.23
K07013XP0	70	96	79.7	86.3	1228	619	3070	1547	51	26	0.26
K08013XP0	80	106	89.7	96.3	1358	661	3393	1653	63	31	0.28
K09013XP0	90	116	99.7	106.3	1551	723	3878	1808	80	37	0.31
K10013XP0	100	126	109.7	116.3	1681	763	4201	1906	95	43	0.34
K11013XP0	110	136	119.7	126.3	1875	820	4686	2050	115	50	0.37
K12013XP0	120	146	129.7	136.3	2004	857	5010	2144	133	57	0.40
K13013XP0	130	156	139.7	146.3	2133	894	5333	2235	152	64	0.43
K14013XP0	140	166	149.7	156.3	2327	948	5817	2368	178	72	0.46
K15013XP0	150	176	159.7	166.3	2456	982	6141	2455	200	80	0.48
K16013XP0	160	186	169.7	176.3	2586	1017	6464	2541	223	88	0.51
K17013XP0	170	196	179.7	186.3	2780	1066	6949	2666	254	98	0.54
K18013XP0	180	206	189.7	196.3	2909	1100	7272	2748	280	106	0.57
K19013XP0	190	216	199.7	206.3	3038	1132	7595	2829	308	115	0.60
K20013XP0	200	226	209.7	216.3	3232	1179	8080	2948	344	125	0.63
K25013XP0	250	276	259.7	266.3	4008	1361	10019	3403	526	179	0.77
K30013XP0	300	326	309.7	316.3	4719	1518	11796	3794	737	237	0.91
K32013XP0	320	346	329.7	336.3	5042	1586	12605	3966	838	264	0.97
K34013XP0	340	366	349.7	356.3	5365	1653	13412	4133	945	291	1.02
K36013XP0	360	386	369.7	376.3	5688	1719	14220	4298	1059	320	1.08

**4 Point Contact Type X**



20mm SERIES											
Kaydon Bearing Number	DIMENSIONS				CAPACITY						Weight kg
	Size (mm)		Land Diameters (mm)		Radial (kg)		Axial (kg)		Moment (kg-M)		
	Bore	O.D.	Land (L1)	Land (L2)	Static	Dyn.	Static	Dyn.	Static	Dyn.	
K02020XP0	20	60	35.0	45.0	873	645	2181	1614	17	13	0.30
K02520XP0	25	65	40.0	50.0	1018	715	2545	1789	23	16	0.34
K05020XP0	50	90	65.0	75.0	1600	967	3999	2418	56	34	0.52
K06020XP0	60	100	75.0	85.0	1745	1025	4363	2562	70	41	0.59
K07020XP0	70	110	85.0	95.0	2036	1136	5090	2839	91	51	0.66
K08020XP0	80	120	95.0	105.0	2181	1189	5454	2973	109	59	0.73
K09020XP0	90	130	105.0	115.0	2473	1293	6181	3231	136	71	0.80
K10020XP0	100	140	115.0	125.0	2618	1343	6545	3357	157	80	0.87
K11020XP0	110	150	125.0	135.0	2909	1441	7272	3601	189	93	0.94
K12020XP0	120	160	135.0	145.0	3200	1535	7999	3837	224	107	1.01
K13020XP0	130	170	145.0	155.0	3345	1581	8363	3953	250	118	1.07
K14020XP0	140	180	155.0	165.0	3636	1672	9090	4179	290	133	1.15
K15020XP0	150	190	165.0	175.0	3781	1716	9453	4290	321	146	1.22
K16020XP0	160	200	175.0	185.0	4072	1803	10180	4507	366	162	1.30
K17020XP0	170	210	185.0	195.0	4363	1887	10907	4719	414	179	1.37
K18020XP0	180	220	195.0	205.0	4508	1929	11271	4823	450	193	1.44
K19020XP0	190	230	205.0	215.0	4800	2011	11999	5029	503	211	1.51
K20020XP0	200	240	215.0	225.0	4945	2052	12362	5130	543	225	1.57
K25020XP0	250	290	265.0	275.0	6108	2362	15271	5906	823	318	2.10
K30020XP0	300	340	315.0	325.0	7272	2654	18179	6633	1161	424	2.30
K32020XP0	320	360	335.0	345.0	7708	2758	19270	6897	1308	468	2.44
K34020XP0	340	380	355.0	365.0	8144	2862	20361	7154	1463	514	2.58
K36020XP0	360	400	375.0	385.0	8581	2963	21452	7408	1627	562	2.73

**4 Point Contact Type X**



Section 6-Other Products

# PRECISION AND FITUP — for Metric Reali-Slim® Bearings shown on pages 88 thru 93

**Kaydon class 1 for A, C, X type bearings All dimensions in millimeters.**

Bearing Size	Bore + .0000	O.D. + .0000	Radial & Axial Runout		Rotating Shaft		Stationary Shaft		BRG. D.C.* Before Inst.			
			Inner	Outer	Shaft Dia. Nom + .000	HSE Bore Nom +.000	Shaft Dia. Nominal	HSE Bore Nominal				
20	-.010	-.010	.008	.010	+.010	+.010	-.010	-.020	-.010	-.020	0.025	0.038
25	-.010	-.010	.008	.010	+.010	+.010	-.010	-.020	-.010	.020	0.025	0.038
50	-.012	-.013	.013	.013	+.012	+.013	-.012	-.024	-.013	-.026	0.030	0.056
60	-.015	-.013	.013	.013	+.015	+.013	-.015	-.030	-.015	-.030	0.030	0.056
70	-.015	-.015	.015	.015	+.015	+.015	-.015	-.030	-.015	-.030	0.030	0.056
80	-.015	-.015	.015	.015	+.015	+.015	-.015	-.030	-.015	-.030	0.030	0.056
90	-.020	-.015	.015	.015	+.020	+.015	-.020	-.040	-.020	-.040	0.041	0.066
100	-.020	-.015	.015	.015	+.020	+.015	-.020	-.040	-.020	-.040	0.041	0.066
110	-.020	-.018	.015	.020	+.020	+.018	-.020	-.040	-.020	-.040	0.041	0.066
120	-.020	-.018	.020	.020	+.020	+.018	-.020	-.036	-.020	-.036	0.051	0.076
130	-.025	-.018	.025	.025	+.025	+.018	-.025	-.051	-.018	-.036	0.051	0.076
140	-.025	-.025	.025	.025	+.025	+.025	-.025	-.051	-.025	-.051	0.051	0.076
150	-.025	-.025	.025	.025	+.025	+.025	-.025	-.051	-.025	-.051	0.051	0.076
160	-.025	-.025	.025	.025	+.025	+.025	-.025	-.051	-.025	-.051	0.051	0.076
170	-.025	-.025	.025	.025	+.025	+.025	-.025	-.051	-.025	-.051	0.051	0.076
180	-.025	-.030	.025	.025	+.025	+.030	-.025	-.051	-.030	-.061	0.051	0.076
190	-.025	-.030	.025	.025	+.025	+.030	-.025	-.051	-.030	-.061	0.051	0.076
200	-.030	-.030	.030	.030	+.030	+.030	-.030	-.061	-.030	-.061	0.061	0.086
250	-.036	-.036	.046	.051	+.036	+.036	-.036	-.071	-.036	-.071	0.071	0.100
300	-.036	-.036	.046	.051	+.036	+.036	-.036	-.071	-.036	-.071	0.071	0.100
320	-.036	-.036	.046	.051	+.036	+.036	-.036	-.071	-.036	-.071	0.071	0.100
340	-.036	-.036	.046	.051	+.036	+.036	-.036	-.071	-.036	-.071	0.071	0.100
360	-.036	-.036	.046	.051	+.036	+.036	-.036	-.071	-.036	-.071	0.071	0.100

\* Diametral clearance after installation theoretically can range rather widely if all contributing bearing, housing, and shaft tolerances are at either of their extremes. Diametral clearances shown do not apply to Type A (angular contact) bearings.

Listed shaft and housing diameters are for steel supports with standard bearing diametral clearance. Recommended shaft and housing diameters can change greatly based on orientation, temperature, speed, non-standard diametral clearances, and desired performance characteristics. Contact Kaydon for design assistance when required.

All dimensions in millimeters.

**CONTACT KAYDON AT—**  
 Kaydon Corporation • Muskegon, Michigan 49443  
 Telephone: 231/755-3741 • Fax: 231/759-4102

**NEED SERVICE FAST?**  
**1-800-514-3066**  
 Website: [www.reali-slim.com](http://www.reali-slim.com)

# Metric Series Ball Bearings (BB Series)

## Drop-in Replacements For Cross-Roller Bearings



*Kaydon BB Metric Series four-point contact ball bearings are dimensionally interchangeable with cross-roller bearings.*

### **BB Series Bearings Are Available to Match the Bores and Widths of Common Cross-Roller Bearings.**

When factors such as cost, availability, corrosion resistance, tighter tolerances, torque, seal/shield options, and temperature resistance are important in your application, it pays to consider BB Series four-point contact metric ball bearings as an alternative to cross-roller bearings. The additional design flexibility they offer can often help you achieve your design objectives with optimum performance and economy.

Additional features not commonly available in standard cross-roller bearings, include a protective package for corrosion resistance, custom sealing for extreme environments, application-specific lubrication and temperature capability.

### **Optimize Your Design Options**

With additional features not commonly available in standard cross-roller bearings, BB Series bearings provide greater design flexibility.

**Endurakote® coating**—For applications requiring superior corrosion resistance, we offer our proprietary Endurakote coating. This thin, dense chrome plating gives AISI 52100 bearing material corrosion resistance equal to or better than that of AISI 440 stainless steel. Unlike many traditional chrome platings, the extremely hard surface of Endurakote coating doesn't peel and flake from the bearing race under stress, so corrosion resistance is retained and surface wear is minimized. The performance of Endurakote has been proven in critical military, aerospace, and deep space applications.

**Seals/Shields**—Standard industry seals are generally available from Buna-N rubber. Kaydon can also provide custom seals manufactured from silicone or Viton® materials for applications where

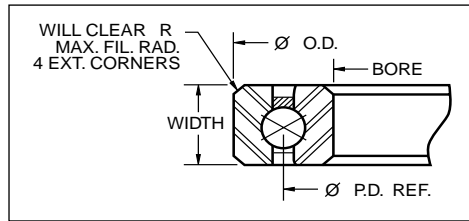
high temperature or extreme environments are likely to be encountered.

**Temperature Capability**—Standard cross-roller bearings have a maximum full capacity operating temperature of only 212°F. In contrast, Kaydon's heat treating procedures allow Kaydon bearings to operate at higher temperatures.

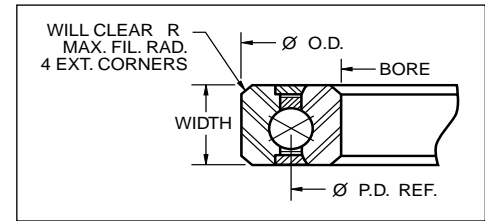
**Lubrication Options**—Kaydon offers a full range of lubricants, allowing you to optimize bearing performance in a range of applications with special requirements for moisture resistance, hot or cold temperatures, vacuum, and low torque.

**Separators**—The common roller spacer for many cross-roller bearings is a non-metallic composite. High temperature and/or horizontal axis applications may require non-standard materials or a non-standard separator design, however. Kaydon four-point contact ball bearings are available with separator options to meet a wide range of applications.

**Internal Fitup**—Kaydon can help you optimize internal fitup of our BB Series four-point contact ball bearings to provide the desired operating performance. Pre-loaded bearings are recommended for greater stiffness, and diametral clearance is recommended for lower torque applications.



**Open Bearing**



**Sealed Bearing**

**BB Series — all dimensions in mm**

(Real-Slim® replacements for RB Series standard cross-roller bearings)

Model No.	Kaydon Part No.	Wt. (kg)	Bore (nominal +0)	O.D. (nominal +0)	Width (nominal +0)	P.D.	"R"	Dynamic Capacity		
								Radial (kg)	Axial (kg)	Moment (kg-M)
BB2008	39316001	0.03	20 -0.01	36 -0.011	8 -0.12	28	0.8	168	420	2.3
BB2508	39317001	0.04	25 -0.01	41 -0.011	8 -0.12	33	0.8	187	469	3.1
BB3010	39318001	0.1	30 -0.01	55 -0.013	10 -0.12	42.5	1	270	675	5.7
BB3510	39319001	0.11	35 -0.012	60 -0.013	10 -0.12	47.5	1	284	709	6.7
BB4010	39320001	0.12	40 -0.012	65 -0.013	10 -0.12	52.5	1	310	776	8.1
BB4510	39321001	0.13	45 -0.012	70 -0.013	10 -0.12	57.5	1	336	839	9.7
BB5013	39322001	0.24	50 -0.012	80 -0.013	13 -0.12	65	1	528	1321	17.2
BB6013	39323001	0.3	60 -0.015	90 -0.013	13 -0.12	75	1	575	1436	21.5
BB7013	39324001	0.31	70 -0.015	100 -0.015	13 -0.12	85	1	640	1601	27.2
BB8016	39325001	0.62	80 -0.015	120 -0.015	16 -0.12	100	1	967	2417	48.3
BB9016	39326001	0.73	90 -0.02	130 -0.015	16 -0.12	110	1.5	1033	2584	56.8
BB10020	39327001	1.21	100 -0.02	150 -0.015	20 -0.12	125	1.5	1392	3480	87.0
BB11015	39328001	0.66	110 -0.02	145 -0.018	15 -0.12	127.5	1	839	2097	53.5
BB11020	39329001	1.36	110 -0.02	160 -0.02	20 -0.12	140	1.5	1488	3720	100.4
BB12025	39330001	2.13	120 -0.02	180 -0.02	25 -0.12	150	2	2298	5745	172.3
BB13025	39331001	2.27	130 -0.025	190 -0.025	25 -0.12	160	2	2387	5968	190.9
BB14025	39332001	2.5	140 -0.025	200 -0.025	25 -0.12	170	2	2561	6402	217.6
BB15013	39333001	0.61	150 -0.025	180 -0.025	13 -0.12	165	1	982	2455	81.0
BB15025	39334001	2.72	150 -0.025	210 -0.025	25 -0.12	180	2	2645	6614	238.0
BB15030	39335001	4.54	150 -0.025	230 -0.025	30 -0.12	190	2	3730	9325	354.2
BB20025	39336001	3.4	200 -0.03	260 -0.03	25 -0.12	230	2.5	3128	7820	359.6
BB20030	39337001	5.72	200 -0.03	280 -0.03	30 -0.12	240	2.5	4392	10980	526.9
BB20035	39338001	8.17	200 -0.03	295 -0.03	35 -0.12	247.5	2.5	5568	13921	688.9
BB25025	39339001	4.09	250 -0.03	310 -0.035	25 -0.12	280	3	3576	8939	500.5
BB25030	39340001	7.04	250 -0.03	330 -0.035	30 -0.12	290	3	5008	12519	725.9
BB25040	39341001	9.08	250 -0.03	355 -0.035	40 -0.12	302.5	3	6324	15812	956.3
BB30025	39342001	4.99	300 -0.035	360 -0.035	25 -0.12	330	3	3929	9821	648.0
BB30035	39343001	11.8	300 -0.035	395 -0.035	35 -0.12	347.5	3	7038	17595	1222.5
BB30040	39344001	15.44	300 -0.035	405 -0.035	40 -0.12	352.5	3	7038	17595	1240.1
BB40035	39345001	12.03	400 -0.04	480 -0.04	35 -0.25	440	3.5	8207	20518	1805.1
BB40040	39346001	20.66	400 -0.04	510 -0.04	40 -0.25	455	3.5	8367	20919	1903.0
BB50040	39347001	22.7	500 -0.045	600 -0.045	40 -0.25	550	3.5	9598	23996	2638.8
BB50050	39348001	38.05	500 -0.045	625 -0.045	50 -0.25	562.5	3.5	9747	24367	2740.4
BB60040	39349001	27.24	600 -0.045	700 -0.045	40 -0.2	650	4	10755	26887	3494.3
BB70045	39350001	44.95	700 -0.045	815 -0.045	45 -0.25	757.5	4	11852	29634	4487.6
BB80070	39351001	98.52	800 -0.05	950 -0.05	70 -0.25	875	5	19119	47799	8362.3
BB90070	39352001	109.87	900 -0.05	1050 -0.05	70 -0.25	975	5	20591	51478	10035.2

Note 1: Capacities listed are not simultaneous. For combined loading see discussion of Bearing Selection and Load Analysis. Dynamic capacities are based upon 1 million revolutions of L10 life. Published capacities do not apply to hybrid series bearings P, X, and Y - contact Kaydon product engineering for values.

Note 2: Standard bearings are supplied without seals and shields, and they are assembled with a light clearance. Alternate features can be obtained by adding the following suffix letter to the basic part number.

- U = single seal      CO = standard clearance      CCO = preload      TT = double shield
- UU = double seal      CI = greater than standard clearance      T = single shield      Check for availability.



**BB Precision Tolerances—all dimensions in mm**

Model Number	Bore (nominal +0)	O.D. (nominal +0)	Width (nominal +0)	Std. Diametral Clearance	Radial and Axial Runout	
					Inner	Outer
BB2008	20 -0.01	36 0.011	8 -0.12	0.025-0.038	0.008	0.01
BB2508	25 -0.01	41 -0.011	8 -0.12	0.025-0.038	0.008	0.01
BB3010	30 -0.01	55 -0.013	10 -0.12	0.025-0.038	0.01	0.01
BB3510	35 -0.012	60 -0.013	10 -0.12	0.03-0.043	0.01	0.01
BB4010	40 -0.012	65 -0.013	10 -0.12	0.03-0.043	0.013	0.013
BB4510	45 -0.012	70 -0.013	10 -0.12	0.03-0.043	0.013	0.013
BB5013	50 -0.012	80 -0.013	13 -0.12	0.03-0.056	0.013	0.013
BB6013	60 -0.015	90 -0.013	13 -0.12	0.03-0.056	0.013	0.013
BB7013	70 -0.015	100 -0.015	13 -0.12	0.03-0.056	0.015	0.015
BB8016	80 -0.015	120 -0.015	16 -0.12	0.03-0.056	0.015	0.015
BB9016	90 -0.02	130 -0.015	16 -0.12	0.041-0.066	0.015	0.015
BB10020	100 -0.02	150 -0.015	20 -0.12	0.041-0.066	0.015	0.015
BB11015	110 -0.02	145 -0.018	15 -0.12	0.041-0.066	0.015	0.02
BB11020	110 -0.02	160 -0.02	20 -0.012	0.041-0.066	0.015	0.02
BB12025	120 -0.02	180 -0.02	25 -0.12	0.05-0.08	0.02	0.02
BB13025	130 -0.025	190 -0.025	25 -0.12	0.05-0.08	0.025	0.025
BB14025	140 -0.025	200 -0.025	25 -0.12	0.05-0.08	0.025	0.025
BB15013	150 -0.025	180 -0.025	13 0.23	0.05-0.08	0.025	0.025
BB15025	150 -0.025	210 -0.025	25 -0.12	0.05-0.08	0.025	0.025
BB15030	150 -0.025	230 -0.025	30 -0.12	0.05-0.08	0.025	0.025
BB20025	200 -0.03	260 -0.03	25 -0.12	0.06-0.09	0.03	0.03
BB20030	200 -0.03	280 -0.03	30 -0.12	0.06-0.09	0.03	0.03
BB20035	200 -0.03	295 -0.03	35 -0.12	0.06-0.09	0.03	0.03
BB25025	250 -0.03	310 -0.035	25 -0.12	0.07-0.1	0.035	0.035
BB25030	250 -0.03	330 -0.035	30 -0.12	0.07-0.1	0.035	0.035
BB25040	250 -0.03	355 -0.035	40 0.12	0.07-0.1	0.035	0.035
BB30025	300 -0.035	360 -0.035	25 -0.12	0.07-0.1	0.035	0.035
BB30035	300 -0.035	395 -0.035	35 -0.12	0.07-0.1	0.035	0.035
BB30040	300 -0.035	405 -0.035	40 -0.12	0.07-0.1	0.035	0.035
BB40035	400 -0.04	480 -0.04	35 -0.25	0.08-0.11	0.04	0.04
BB40040	400 -0.04	510 -0.04	40 -0.2	0.08-0.11	0.04	0.04
BB50040	500 -0.045	600 -0.045	40 -0.25	0.09-0.12	0.045	0.045
BB50050	500 -0.045	625 -0.045	50 -0.25	0.09-0.12	0.045	0.045
BB60040	600 -0.045	700 -0.045	40 -0.25	0.09-0.12	0.045	0.045
BB70045	700 -0.045	815 -0.045	45 -0.25	0.09-0.12	0.045	0.045
BB80070	800 -0.05	950 -0.05	70 -0.25	0.09-0.12	0.05	0.05
BB90070	900 -0.05	1050 -0.05	70 -0.25	0.1-0.13	0.05	0.05

**CONTACT KAYDON AT—**

Kaydon Corporation • Muskegon, Michigan 49443  
 Telephone: 231/755-3741 • Fax: 231/759-4102

**NEED SERVICE FAST?**

**1-800-514-3066**

Website: [www.reali-slim.com](http://www.reali-slim.com)

# New Ultra-Slim™ Thin-Section Bearings

**Ideal for applications in robotics, inspection equipment, satellites, cameras... anywhere precise positioning and lightweight designs are critical.**

At just 2.5 mm wide, Ultra-Slim bearings are available in bore sizes ranging from 35 mm to 170 mm for an array of applications. Their compact profile allows you to use Ultra-Slim bearings in the most confined design envelopes you can imagine.

Precision-engineered Ultra-Slim bearings are made of stainless steel for corrosion resistance. They are available in angular contact (Type A), radial contact (Type C), and four-point-contact (Type X) styles. (See selection charts at right).

Hybrid bearings with ceramic balls are available upon request. These configurations are used often when lubrication is marginal or when lower wear generation and/or lower torque levels are required.

## How to identify Ultra-Slim™ Bearings using our part number code

Position	1	2	3	4	5	6	7	8	9	10
Nomenclature	Material	Bore (mm)			Radial Section (mm)		Type	Separator	Precision	Internal Fit
Example	S	1	1	0	0	3	C	S	0	K

### Position 1—Material

S = 440C races and balls (Standard for Series)  
K = 52100 races and balls

### Position 2, 3 and 4—Bore

Nominal bearing bore in mm.

### Position 5 and 6—Width

Nominal radial race width in mm.

### Position 7—Bearing Type

A = Angular Contact  
C = Radial Contact  
X = 4-Point Contact

### Position 8—Separator

S = Spacer balls  
F = Full complement of load balls

### Position 9—Precision

0 = Kaydon standard precision class

### Position 10—Internal Fit

A = 0.000 - 0.130 mm clearance  
C = 0.013 - 0.025 mm clearance  
E = 0.025 - 0.510 mm clearance  
K = 0.000 - 0.013 mm preload  
M = 0.013 - 0.025 mm preload  
= standard internal fitup if not specified

## Performance and Application Considerations

Ultra-Slim bearings are unique in that their extremely thin cross section enables them to provide great size and weight reductions for light to medium duty applications with slow or intermittent rotation.

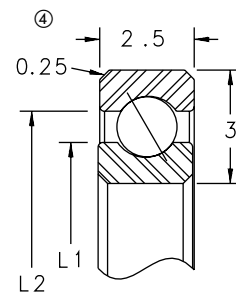
Given the fact that these bearings will most likely be used in lightly loaded applications where saving weight and space are the main objective, the loading values shown assume that the shaft and housing will also be of a light construction. This will allow for greater bearing ring movement under load than traditional heavy section bearings. Thus the *loading limits* for capacity are not based on ABMA standards.

Depending on the support provided by the shaft and housing, this movement can create increased stress levels within the bearing. Distortion of the shaft and housing under load will transfer to the bearing, causing increased stress levels which could lead to premature failure and/or erratic torque conditions.

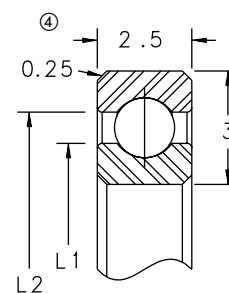
The impact of non-uniform shaft and housing distortions is best found by testing. If problems are experienced, increased rigidity of the shaft and housing may be necessary. If the shaft and housing are of sufficient rigidity, it may be possible for the bearings to support greater loads than the loading limits provided.

# Ultra-Slim™ Bearing Selection Data

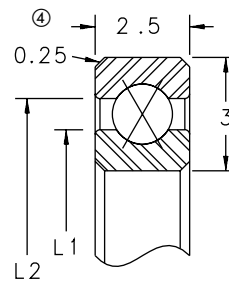
Angular Contact Type A								
Kaydon Bearing Number	Dimensions in mm				Capacity		Loading Limits	Mass in Grams
	Bore	Outside Diameter	Land Dia. L <sub>1</sub>	Land Dia. L <sub>2</sub>	Radial Newtons		Thrust Newtons <sup>③</sup>	
					Static <sup>①</sup>	Dyn. <sup>②</sup>		
S03503AS0	35	41	37.2	38.8	382	383	1334	5
S06003AS0	60	66	62.2	63.8	649	552	1112	9
S07003AS0	70	76	72.2	73.8	756	609	1068	11
S07403AS0	74	80	76.2	77.8	799	632	1045	11
S08003AS0	80	86	82.2	83.8	863	663	1001	12
S09003AS0	90	96	92.2	93.8	970	716	956	13
S10003AS0	100	106	102.2	103.8	1077	765	890	15
S11003AS0	110	116	112.2	113.8	1183	814	867	16
S12003AS0	120	126	122.2	123.8	1290	863	823	18
S13003AS0	130	136	132.2	133.8	1407	912	778	19
S14003AS0	140	146	142.2	143.8	1514	956	734	21
S15003AS0	150	156	152.2	153.8	1621	1001	712	22
S16003AS0	160	166	162.2	163.8	1727	1045	689	24
S17003AS0	170	176	172.2	173.8	1834	1085	667	25



Radial Contact Type C							
Kaydon Bearing Number	Dimensions in mm				Capacity		Mass in Grams
	Bore	Outside Diameter	Land Dia. L <sub>1</sub>	Land Dia. L <sub>2</sub>	Radial Newtons		
					Static <sup>①</sup>	Dynamic <sup>②</sup>	
S03503CS0	35	41	37.2	38.8	418	418	5
S06003CS0	60	66	62.2	63.8	711	605	9
S07003CS0	70	76	72.2	73.8	827	667	11
S07403CS0	74	80	76.2	77.8	875	689	11
S08003CS0	80	86	82.2	83.8	944	725	12
S09003CS0	90	96	92.2	93.8	1062	783	13
S10003CS0	100	106	102.2	103.8	1178	841	15
S11003CS0	110	116	112.2	113.8	1295	894	16
S12003CS0	120	126	122.2	123.8	1412	943	18
S13003CS0	130	136	132.2	133.8	1540	1001	19
S14003CS0	140	146	142.2	143.8	1658	1050	21
S15003CS0	150	156	152.2	153.8	1774	1099	22
S16003CS0	160	166	162.2	163.8	1891	1143	24
S17003CS0	170	176	172.2	173.8	2006	1192	25



4-Point Contact Type X									
Kaydon Bearing Number	Dimensions in mm				Capacity		Loading Limits		Mass in Grams
	Bore	Outside Diameter	Land Dia. L <sub>1</sub>	Land Dia. L <sub>2</sub>	Radial Newtons		Thrust Newtons <sup>③</sup>	Moment Nm <sup>③</sup>	
					Static <sup>①</sup>	Dyn. <sup>②</sup>			
S03503XS0	35	41	37.2	38.8	711	585	1045	7.9	5
S06003XS0	60	66	62.2	63.8	1208	847	934	11.8	9
S07003XS0	70	76	72.2	73.8	1407	934	890	13.0	11
S07403XS0	74	80	76.2	77.8	1487	965	867	13.4	11
S08003XS0	80	86	82.2	83.8	1606	1015	845	14.0	12
S09003XS0	90	96	92.2	93.8	1805	1096	801	14.9	13
S10003XS0	100	106	102.2	103.8	2003	1177	756	15.6	15
S11003XS0	110	116	112.2	113.8	2201	1252	734	16.6	16
S12003XS0	120	126	122.2	123.8	2400	1320	689	17.0	18
S13003XS0	130	136	132.2	133.8	2618	1401	645	17.2	19
S14003XS0	140	146	142.2	143.8	2818	1470	623	17.8	21
S15003XS0	150	156	152.2	153.8	3016	1538	601	18.4	22
S16003XS0	160	166	162.2	163.8	3215	1600	578	18.9	24
S17003XS0	170	176	172.2	173.8	3413	1669	556	19.2	25



① Static radial capacities are based on maximum allowable contact stresses. Adequate support of the races is assumed to help assure uniform ball support.  
 ② Dynamic radial capacities are included for life calculation purposes. These are based on the assumption that the shaft and housing have adequate strength to support the loads without causing excessive distortion of the bearing rings. For combined loading, use the formulas supplied to determine an equivalent radial load to calculate the L10 bearing life. In all cases, the individual loads must not exceed the loading limits provided. (see equations on next page)  
 ③ Higher loading limits may be achieved with sufficiently rigid supports that will better restrict the movement of the bearing races under load.  
 ④ Corner size is the maximum shaft or housing fillet radius that the bearing corners will clear.

Section 6-Other Products

# Ultra-Slim Bearing Precision Tolerances (Dimensions in mm.)

Bearing Bore	① Bore and O.D. Tolerances	② Radial and Axial Race Runouts		Bearing Diametral Clearance, Type X & C		Rotating Shaft		Stationary Shaft	
	Nominal +0.000	Inner Race	Outer Race	Before Installation		Shaft Diameter	Housing Bore	Shaft Diameter	Housing Bore
35	-0.013	0.010	0.010	0.030	0.046	35 +0.013/-0.000	41 +0.013/-0.000	34.987 +0.000/-0.013	40.987 +0.000/-0.013
60	-0.013	0.013	0.013	0.030	0.046	60 +0.013/-0.000	66 +0.013/-0.000	59.987 +0.000/-0.013	65.987 +0.000/-0.013
70	-0.013	0.015	0.015	0.030	0.046	70 +0.013/-0.000	76 +0.013/-0.000	69.987 +0.000/-0.013	75.987 +0.000/-0.013
74	-0.013	0.015	0.015	0.030	0.046	74 +0.013/-0.000	80 +0.013/-0.000	73.987 +0.000/-0.013	79.987 +0.000/-0.013
80	-0.013	0.015	0.015	0.030	0.046	80 +0.013/-0.000	86 +0.013/-0.000	79.987 +0.000/-0.013	85.987 +0.000/-0.013
90	-0.013	0.015	0.015	0.030	0.046	90 +0.013/-0.000	96 +0.013/-0.000	89.987 +0.000/-0.013	95.987 +0.000/-0.013
100	-0.013	0.015	0.015	0.030	0.046	100 +0.013/-0.000	106 +0.013/-0.000	99.987 +0.000/-0.013	105.987 +0.000/-0.013
110	-0.013	0.020	0.020	0.030	0.046	110 +0.013/-0.000	116 +0.013/-0.000	109.987 +0.000/-0.013	115.987 +0.000/-0.013
120	-0.013	0.020	0.020	0.030	0.046	120 +0.013/-0.000	126 +0.013/-0.000	119.987 +0.000/-0.013	125.987 +0.000/-0.013
130	-0.013	0.020	0.020	0.030	0.046	130 +0.013/-0.000	136 +0.013/-0.000	129.987 +0.000/-0.013	135.987 +0.000/-0.013
140	-0.013	0.025	0.025	0.030	0.046	140 +0.013/-0.000	146 +0.013/-0.000	139.987 +0.000/-0.013	145.987 +0.000/-0.013
150	-0.013	0.025	0.025	0.030	0.046	150 +0.013/-0.000	156 +0.013/-0.000	149.987 +0.000/-0.013	155.987 +0.000/-0.013
160	-0.013	0.025	0.025	0.030	0.046	160 +0.013/-0.000	166 +0.013/-0.000	159.987 +0.000/-0.013	165.987 +0.000/-0.013
170	-0.013	0.025	0.025	0.030	0.046	170 +0.013/-0.000	176 +0.013/-0.000	169.987 +0.000/-0.013	175.987 +0.000/-0.013

① Diameter tolerances apply to average dimensions. Due to the thin nature of these bearings, they cannot be measured with 2 point gauges.

② The runout values apply to individual bearing races.

# KT Series Tapered Roller Bearings

The Kaydon concept of standard bearings with light-weight, thin-sections, and large bore diameters includes tapered and radial roller bearings as well as ball bearings.

KT Series tapered roller bearings offer advantages to those designs requiring a bearing of higher capacity, which would benefit from the many unique advantages of a thin-section bearing. KT tapered roller bearings are used to advantage in applications ranging from oil field equipment to machine tool tables where space and weight considerations are meaningful.



Standard tapered roller bearings, KT Series, have races and rollers of through-hardened AISI 52100 vacuum degassed steel with a one-piece stamped steel cage. They can be furnished, when specified, in pairs match ground for use with or without spacers.

The Tapered Roller Bearings in this catalog are of the single-row radial type, designed primarily for application of radial load. While of separable construction, the rolling elements are retained in the separator.

Since this bearing assumes a contact angle of approximately 12° under an axial force, it does have a reasonable amount of thrust capacity. This capacity is uni-directional and is realized when the axial force is applied to the wide faces of the races.

As in the case of the angular contact ball bearing, the single row tapered roller bearing is commonly mounted in opposition to another bearing (usually of similar construction) to provide an axial force for establishing and maintaining the angle of contact. Two bearings of this type may be mounted with the lines of contact converging outside of the bearings (back-to-back) or inside (face-to-face) with the former preferred for stability in the presence of overturning load.

Kaydon Bearing Number	Bore d (IN)	Outside Dia. D (IN)	Assem. Width T (IN)	Factor K (IN)	Rating at 500 RPM for 3000 hrs. L-10		Cone Width B (IN)	Cup Width C (IN)	Shoulder Diameters				Bearing Wt. (LB)
					Radial (LB)	Thrust (LB)			Shaft		Housing		
									S1 (IN)	S2 (IN)	H1 (IN)	H2 (IN)	
• KT-070	7.000	8.500	.812	1.74	4970	2860	.812	.625	7.375	7.300	8.125	8.250	3.11
• KT-091	9.125	10.250	.718	1.79	4920	2750	.722	.597	9.625	9.312	9.850	10.050	2.88
• KT-098	9.875	11.500	1.062	1.85	9260	5000	1.062	.875	10.375	10.225	11.063	11.250	6.05
• KT-100	10.000	11.125	.625	1.79	4020	2250	.625	.500	10.500	10.300	10.750	10.900	2.88
• KT-110	11.000	12.500	.875	1.86	7620	4100	.875	.688	11.438	11.250	12.000	12.250	5.06
• KT-112	11.250	12.750	.812	1.86	7150	3860	.812	.625	11.688	11.500	12.313	12.500	4.72
• KT-118	11.875	13.562	.937	1.76	7250	4120	.812	1.125	12.438	12.210	13.000	13.320	6.63
• KT-130	13.000	14.562	.843	1.44	5580	3880	.843	.594	13.438	13.320	14.125	14.300	5.20
• KT-132	13.250	15.000	.937	1.69	6160	3650	.937	.750	13.875	13.625	14.375	14.500	6.79
• KT-151	15.125	17.375	1.125	1.72	11760	6840	1.125	.812	15.750	15.625	16.750	16.875	13.57
• KT-165	16.500	18.750	.875	1.78	8220	4620	.882	.812	17.250	17.000	18.125	18.500	11.14
• KT-180	18.000	19.625	.812	1.69	7400	4330	.812	.687	18.438	18.375	19.188	19.300	8.19
• KT-200	20.000	21.750	.812	1.80	7930	4400	.812	.687	20.625	20.375	21.125	21.250	9.78

• Available from Stock—check for availability of other sizes.

Tolerances are: Bore: +.001" – .000" up to KT-110; +.002" – .000" for KT-110 to KT-200

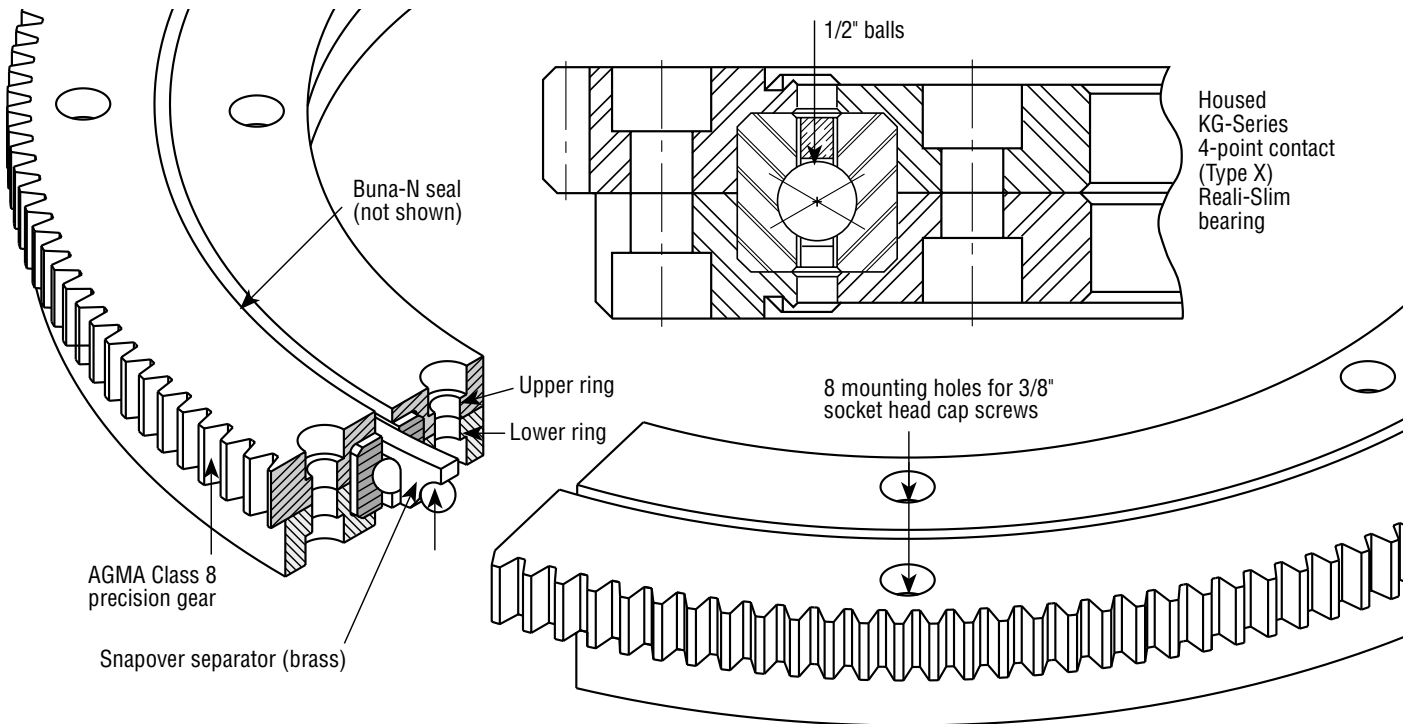
Outside Diameter: Same as for bore.

Width: ±.010" up to KT-112; ±.015" for KT-112 to KT-200

Cup Radial Runout .0015" Max. F.I.M., Cone Radial Runout .0020" Max. F.I.M.

# Reali-Slim® TG Series Bearings

## New Easy-Mount Bearing/Gear Assemblies Give High Rotational Accuracy



### Designed Especially for Precision Applications

- Rotary tables
- Material handling equipment
- Robots
- Balancing systems
- Grinding tables
- Polishing tables
- Positioning systems

Reali-Slim® TG Series bearings are modular bearing/gear assemblies that have been specifically designed to simplify mounting. Based on Reali-Slim® KG Series Type X bearings, TG Series bearings are ideal for use in continuous rotation applications that require ABEC 1 Type precision in a mounted bearing design. They provide greater precision and rotational accuracy than are available from standard turntable bearings.

The unmatched rotational accuracy inherent in TG Series mounted bearings results from a combination of the unique internal geometry of the four-point contact Type X bearing—a design well-known for its ability to minimize axial movement—and the precision of the rings in which we mount them. Our modular, pre-engineered approach to TG Series bearings allows us to combine the bene-

fits of customization with the convenience and economy of an off-the-shelf bearing assembly. This significantly reduces both the lead time and the costs associated with prototyping a bearing for a specific precision application.

TG Series bearing assemblies can be mounted on either vertical or horizontal shafts—without the need for machining operations such as milling, drilling, or grinding.

They are available in geared (internal and external) and non-geared configurations. They also feature a full, formed-ring “snapover” type separator, through-hardened replaceable bearings, space-saving Buna-N seals, optional relube provisions, and they are available in bore sizes from 16" to 30".

**Part Number**

	TG160	TG180	TG200	TG220	TG250	TG300
--	-------	-------	-------	-------	-------	-------

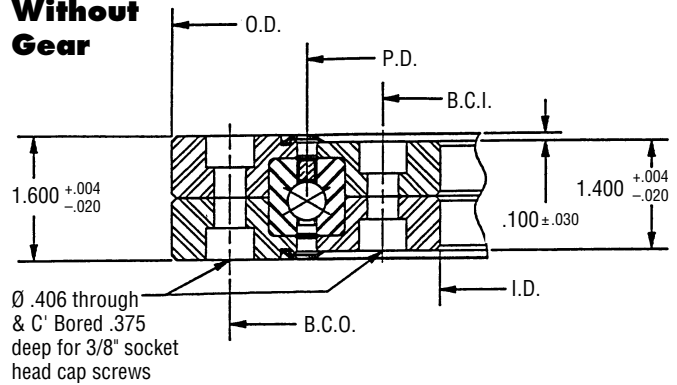
**Dimensions and Tolerances**

I.D. +000 -002	13.500	15.500	17.500	19.500	22.500	27.500
O.D. +000 -002	20.500	22.250	24.500	26.500	29.500	34.500
P.D. (BASIC)	17.000	19.000	21.000	23.000	26.000	31.000
B.C.O. ⊕ .015	19.000	21.000	23.000	25.000	28.000	33.000
B.C.I. ⊕ .015	15.000	17.000	19.000	21.000	24.000	29.000
G.P.D. EXT (BASIC)	20.250	22.250	24.250	26.250	29.250	34.250
# Teeth (EXT)	162	178	194	210	234	274
G.P.D. INT (BASIC)	13.750	15.750	17.750	19.750	22.750	27.750
# Teeth (INT)	110	126	142	158	182	222
# Bolts	12	14	16	18	20	24
C.O.D.	19.818	21.818	23.818	25.818	28.818	33.818
C.I.D.	14.182	16.182	18.182	20.182	23.182	28.182
Axial Runout	.0033	.0033	.0038	.0038	.0038	.0038
Diametral Clearance	.0032 .0042	.0032 .0042	.0036 .0046	.0036 .0046	.0036 .0046	.0036 .0046
Uses R/S BRG	KG 160XP0	KG 180XP0	KG 200XP0	KG 220XP0	KG 250XP0	KG 300XP0

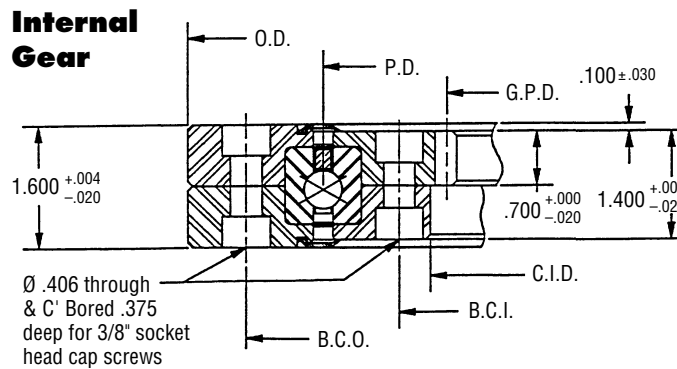
**Bearing Capacities**

Dynamic Capacity (1 Million Rev. L10)						
Radial (lbs)	10180	10960	11710	12610	13510	15190
Thrust (lbs)	25440	27400	29290	31530	33780	37980
Moment (in-lbs)	86520	104140	123050	149350	175660	235500
Static Capacity (Non-Brinell Limit)						
Radial (lbs)	27900	31190	34470	38570	42680	50890
Thrust (lbs)	69760	77970	86180	96440	106700	127220
Moment (in-lbs)	237210	296300	361970	458410	554860	788780

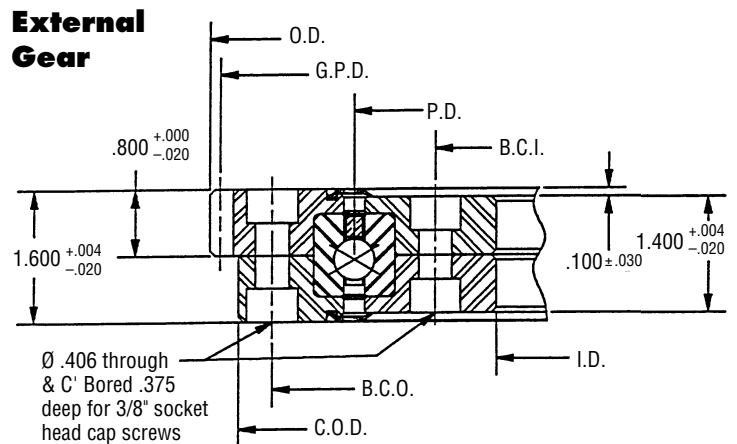
**Without Gear**



**Internal Gear**



**External Gear**



**Gear Data - All Sizes**

Profile: 8DP, 20°, full depth involute  
 Precision: AGMA Class 8  
 Capacity: Tangential tooth capacity, external gear – 1,700 lbs  
 Tangential tooth capacity, internal gear – 2,000 lbs  
 Tooth thickness: (Circular) – .196/.191

## **Section 7— Appendix and Sales Information**

- **Terms and Definitions.....pg. 105**
- **Warranty Information.....pg. 106**
- **Application Data Form.....pg. 107**
- **Engineering Design Aids  
and Technical Literature .....pgs. 108-109**
- **Turntable Bearing Overview.....pg. 110**



# Bearing Definitions and Terms

## Axial Clearance:

The total amount of free axial movement between the inner and outer race of a bearing. Bearings with internal clearance will contain both axial and radial clearance.

## Axial Load:

Also known as thrust load, it is load applied to the bearing parallel with the bearing axis of rotation.

## Capacity:

Dynamic capacity is the basic “C” rating which represents a load that the bearing can theoretically endure for 1 million revolutions. Static capacity is the approximate load the bearing can endure before permanent deformation occurs on the ball or raceway. Published capacities do not apply to hybrid series bearings P, X, and Y. Contact Kaydon product engineering.

## Deflection:

The amount of movement associated with compression or stretching of bearing components when placed under load.

## Diameter Tolerance:

The range in which the average diameter of a bore or O.D. may fall. Reali-Slim® bearings are considered “non-rigid” rings and all diameters are averaged using multi-point gaging techniques per ABMA Std. 26.2.

## Diametral Clearance:

Also referred to as radial clearance, it is the total free movement of the inner race relative to the outer race in a radial plane. “X” and “C” type bearings are made with some internal clearance as a standard factory internal fit before mounting.

## L10 Life:

The theoretical life span of a bearing under a specific set of dynamic operating conditions associated with 90% reliability.

## Moment Load:

Load such that when applied to a bearing system, tends to overturn or bend the axis of rotation in an angular direction.

## Pitch Diameter:

The theoretical median diameter of a bearing, which passes through the center of the rolling elements. Reali-Slim® pitch diameters are equivalent to:  $(OD+Bore)/2$ .

## Preload:

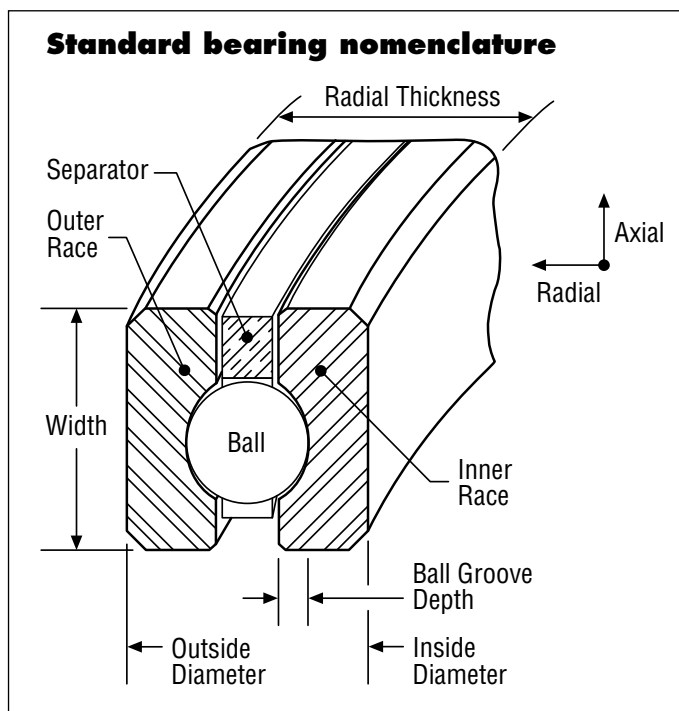
The amount of load placed on the rolling elements before the application of any external loads. Preload can be created in “X” and “C” type bearings by controlling internal fits of the ball and the raceway at the factory. Preload in angular contact bearings is controlled by a “preload gap” between the duplexed races. Tight mounting conditions will increase the final bearing preload. Preload stiffens the bearing and eliminates axial and radial play, but the load on the balls increases friction and shortens L10 life.

## Radial Load:

Load applied perpendicular to the bearing axis of rotation.

## Runout:

The maximum axial or radial race wall thickness variation of an inner or outer bearing race. Runout influences the repeatable location variation of rotating components.



## Warranty

Kaydon Corporation (hereinafter “seller” or “Kaydon”) warrants the products manufactured by it to be free from defects in materials and workmanship only. The extent of Seller’s obligation hereunder is to either repair or replace its work or the defective products, F.O.B. Seller’s plant, if returned within 12 months after date of delivery. No allowance will be granted for repairs or alterations made by Buyer without Seller’s written approval. The warranty shall not be construed to cover the cost of any work done by Buyer on material furnished by Seller or the cost of removal or installation of product.

Products and parts not manufactured by Seller are warranted only to the extent and in the manner that the same are warranted to Seller by Seller’s vendors and then only to the extent Seller is able to enforce such warranty. There is no other warranty, express or implied in fact or by law.

THE FOREGOING STATES THE SOLE AND EXCLUSIVE WARRANTY OF SELLER. THE WARRANTIES STATED HEREIN ARE IN LIEU OF ALL OTHER WARRANTIES, WRITTEN OR VERBAL, STATUTORY, EXPRESSED OR IMPLIED, INCLUDING WARRANTIES OF MERCHANTABILITY AND FITNESS FOR A PARTICULAR PURPOSE, WHICH ARE HEREBY DISCLAIMED. SELLER SHALL NOT BE LIABLE FOR DAMAGES, INCLUDING BUT NOT LIMITED TO, CONSEQUENTIAL OR SPECIAL DAMAGES ARISING OUT OF OR IN CONNECTION WITH THE USE OR PERFORMANCE OF THE PRODUCTS.

Buyer acknowledges that bearing life is directly impacted by the following, over which Seller has no control (including but not limited to) (i) assembly procedures, (ii) mating component dimensions and/or tolerances, (iii) running loads, (iv) environmental exposure, (v) thermal deviations and (vi) proper maintenance procedures.

Seller’s agreement to sell the products is made upon the condition and agreement that, with respect to its products, there have been no representations or undertakings made by or on behalf of Seller and Seller makes no guarantees or warranties, express or implied, in fact or in law, except as expressly stated above.

## Changes

Kaydon reserves the right to change specifications and other information (included) in Kaydon catalogs without notice. We recommend that you contact your Regional Sales Manager or Kaydon to be sure the information you have is current.

## Errors

All information, data, and dimension tables in this catalog have been carefully compiled and thoroughly checked. However, no responsibility for possible errors or omissions is assumed by Kaydon.

## Important Notice

Because of possible danger to persons or property from accidents which may result from the use of the products described in this catalog, it is important that good design practices and correct procedures be followed. The products must be used in accordance with the engineering information provided herein; and proper installation, lubrication, maintenance, and periodic inspection must be assured. It is strongly recommended that appropriate instructions be incorporated in equipment manuals to assure safe operation under all conditions. Proper guards and other suitable safety devices or procedures as may be desirable or as may be specified in safety codes should be provided, and are neither provided by Kaydon nor are the responsibility of Kaydon.

*The product capability statements and engineering specifications in this catalog supersede those detailed in all prior versions of the catalog.*

# Bearing Application Data

**Copy, fill out and fax to 231-759-4102**

Please answer the questions on this form as completely as possible. Include a drawing (or sketch) of the application if available. Be sure to show all parts and information relevant to the application. The data you supply is the basis for our recommendations.

TO: Kaydon Corporation, Muskegon, Michigan 49443 Date: \_\_\_\_\_

Fax: 231/759-4102

FROM: Name \_\_\_\_\_ Title \_\_\_\_\_

Company \_\_\_\_\_ Telephone \_\_\_\_\_

Address \_\_\_\_\_

E-mail \_\_\_\_\_

Application \_\_\_\_\_ Project \_\_\_\_\_

Experimental  Prototype  Production  Other

Quantity \_\_\_\_\_ Original Equipment Manufacturer  Resale  Own Use  Replacement

LOADS: Static Radial (Max.) \_\_\_\_\_ Dynamic Radial (Mean) \_\_\_\_\_

Static Thrust (Max.) \_\_\_\_\_ Dynamic Thrust (Mean) \_\_\_\_\_

Static Moment (Max.) \_\_\_\_\_ Dynamic Moment (Mean) \_\_\_\_\_

If mean dynamic loads are unknown, attach all conditions with percent of time each occurs.

Vibration or shock \_\_\_\_\_ Describe \_\_\_\_\_

Factor of Safety of \_\_\_\_\_ (is) (is not) included in loads above.

SPEED: RPM (Max.) \_\_\_\_\_ RPM (Mean) \_\_\_\_\_ or attach conditions with percent of time.

OSCILLATION: Angle \_\_\_\_\_° Frequency \_\_\_\_\_

ACCURACY: Kaydon Precision Class \_\_\_\_\_ or:

Permissible Eccentricity: Inner \_\_\_\_\_ Outer \_\_\_\_\_

Permissible Face Run-Out: Inner \_\_\_\_\_ Outer \_\_\_\_\_

Permissible Looseness: Radial \_\_\_\_\_ Axial \_\_\_\_\_

LIFE: Hours (Min.) \_\_\_\_\_ Hours (Avg.) \_\_\_\_\_ Other \_\_\_\_\_

TEMPERATURE: Normal Operating \_\_\_\_\_°F Minimum \_\_\_\_\_°F Maximum \_\_\_\_\_°F.

Differential between shaft and housing \_\_\_\_\_°F.

LUBRICATION: Proposed Lubricant \_\_\_\_\_ and method \_\_\_\_\_

BEARING: Preferred Size: Bore \_\_\_\_\_ Outside Dia. \_\_\_\_\_ Width \_\_\_\_\_

Min. Bore \_\_\_\_\_ Max. Outside Dia. \_\_\_\_\_ Max. Width \_\_\_\_\_

Preferred Type: \_\_\_\_\_

Bearing Axis in (Vertical) (Horizontal) position with (outer) (inner) race rotation relative to load.

MATERIAL: Shaft \_\_\_\_\_ Housing \_\_\_\_\_

SPECIAL: Allowable Friction Torque \_\_\_\_\_

REQUIREMENTS: Sealing \_\_\_\_\_

Protective Coating \_\_\_\_\_

Other \_\_\_\_\_

REMARKS: \_\_\_\_\_

\_\_\_\_\_

# Application Information to Help In Your Designs



**1. Reali-Slim® thin-section bearings catalog**

Complete engineering and selection information on the entire product line, including Metric Reali-Slim and Ultra-Slim series. Request Catalog 300.



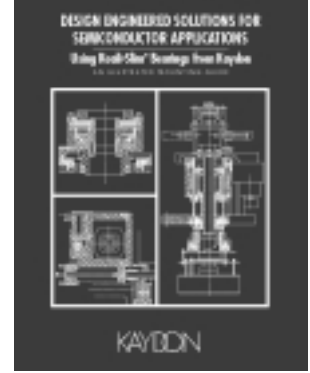
**2. Reali-Slim® bearings for special applications**

A selection guide for bearings used in high temperature, low torque, cleanroom and chemical environments. 12-pages. Request Catalog 307.



**3. An illustrated mounting guide for Reali-Slim® bearings**

Gives ideas on how to improve designs through better mounting and use of bearing assemblies. 24-pages. Request Catalog 306.



**4. An illustrated mounting guide for Reali-Slim® bearings in semiconductor applications**

Generic designs showing how Kaydon Bearings have been used in semiconductor manufacturing equipment. Request Catalog 310. 16 pages.



**5. Reali-Design™ software on CD**

Speeds Reali-Slim® bearing selection process. Includes data sheets, life calculations, CAD-ready DXF library, and metric conversions.



**6. Large turntable bearing catalog**

Complete engineering and selection information on standard and custom turntable bearings. 32-pages. Request Catalog 390.

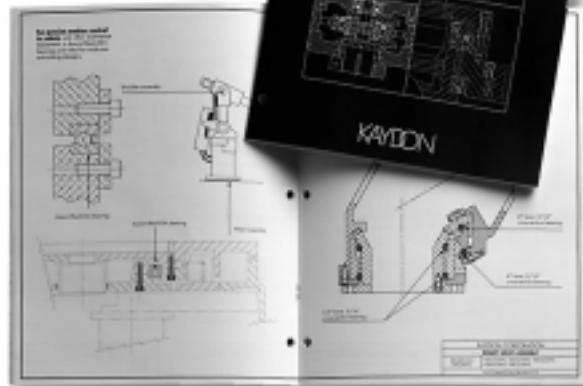


**7. Worm drive rotation systems**

Selection guide for pre-tested, compact bearing/worm assemblies for light-to-medium duty applications. 4-pages. Request Catalog 308.



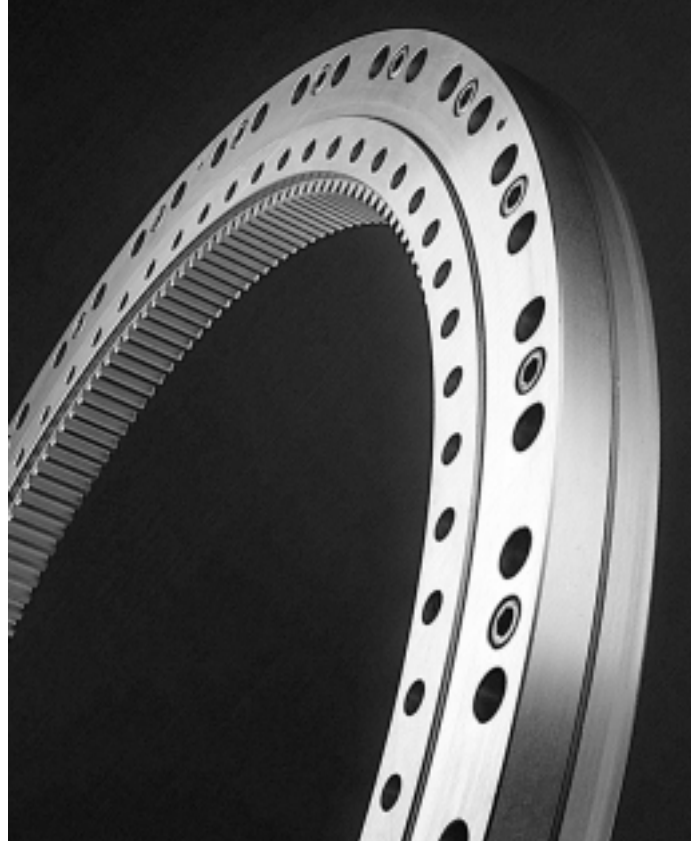
**For catalog, software, or CAD drawing downloads as well as catalogs online, visit our website at [www.reali-slim.com](http://www.reali-slim.com).**



# Custom Turntable Bearings from Kaydon

Custom designs-Our design engineers work with yours to specify the optimum bearing solution for your application.

- Ball and roller bearings in single and multi-row designs.
- Up to 180" O.D.
- Solid and wire race designs.
- Geared races; internal or external.
- Optional materials.
- Induction and through hardened races.
- Precision gears, runouts, preloads, and torque control to suit specific applications.



## **CONTACT KAYDON AT—**

Kaydon Corporation • Muskegon, Michigan 49443  
Telephone: 231/755-3741 • Fax: 231/759-4102

## **NEED SERVICE FAST?**

**1-800-514-3066**

Website: [www.reali-slim.com](http://www.reali-slim.com)



**Your  
portal  
to save  
design  
time!**



**Visit our new web site to download the latest engineering tools for Reali-Slim® thin-section bearings, including:**

- 3D CAD drawings
  - Reali-Design™ software
  - .pdf version of Reali-Slim catalog
- www.reali-slim.com** saves you time and helps you improve your design efficiency!

## **Please send me more information on Reali-Slim® bearings:**

- #300 REALI-SLIM® Bearing Selection Guide
- #306 REALI-SLIM® Mounting Guide
- #307 REALI-SLIM® Special Applications
- REALI-DESIGN™ CD for REALI-SLIM® Bearings



Name \_\_\_\_\_ Title \_\_\_\_\_  
 Company \_\_\_\_\_ Mailstop/Dept. \_\_\_\_\_  
 Address \_\_\_\_\_ E-mail: \_\_\_\_\_  
 City \_\_\_\_\_ State \_\_\_\_\_ Zip \_\_\_\_\_  
 Phone ( \_\_\_\_ ) \_\_\_\_\_ Fax ( \_\_\_\_ ) \_\_\_\_\_

Printed in U.S.A.

## **Please send me more information on large bearings:**

- #390 Large Bearing Catalog and Design Manual
- #308 Worm Drive Rotating System Catalog
- Stock Turntable Bearing Brochure



Name \_\_\_\_\_ Title \_\_\_\_\_  
 Company \_\_\_\_\_ Mailstop/Dept. \_\_\_\_\_  
 Address \_\_\_\_\_ E-mail: \_\_\_\_\_  
 City \_\_\_\_\_ State \_\_\_\_\_ Zip \_\_\_\_\_  
 Phone ( \_\_\_\_ ) \_\_\_\_\_ Fax ( \_\_\_\_ ) \_\_\_\_\_

Printed in U.S.A.





TURNING IDEAS INTO ENGINEERED SOLUTIONS

Visit our website: [www.reali-slim.com](http://www.reali-slim.com)

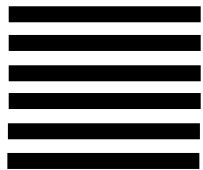


NO POSTAGE  
NECESSARY IF  
MAILED IN THE  
UNITED STATES

**BUSINESS REPLY MAIL**  
FIRST-CLASS MAIL PERMIT NO 1182 MUSKEGON MI

POSTAGE WILL BE PAID BY ADDRESSEE

MARKETING DEPARTMENT  
KAYDON CORPORATION  
PO BOX 688  
MUSKEGON MI 49443-9963

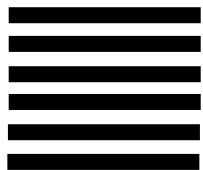


NO POSTAGE  
NECESSARY IF  
MAILED IN THE  
UNITED STATES

**BUSINESS REPLY MAIL**  
FIRST-CLASS MAIL PERMIT NO 1182 MUSKEGON MI

POSTAGE WILL BE PAID BY ADDRESSEE

MARKETING DEPARTMENT  
KAYDON CORPORATION  
PO BOX 688  
MUSKEGON MI 49443-9963





**Kaydon Corporation**  
2860 McCracken Street  
Muskegon, Michigan 49441 U.S.A.  
**Phone:** (231) 755-3741  
**Fax:** (231) 759-4102

***Need Service Fast?***  
**1-800-514-3066**

Visit our website: [www.reali-slim.com](http://www.reali-slim.com)